

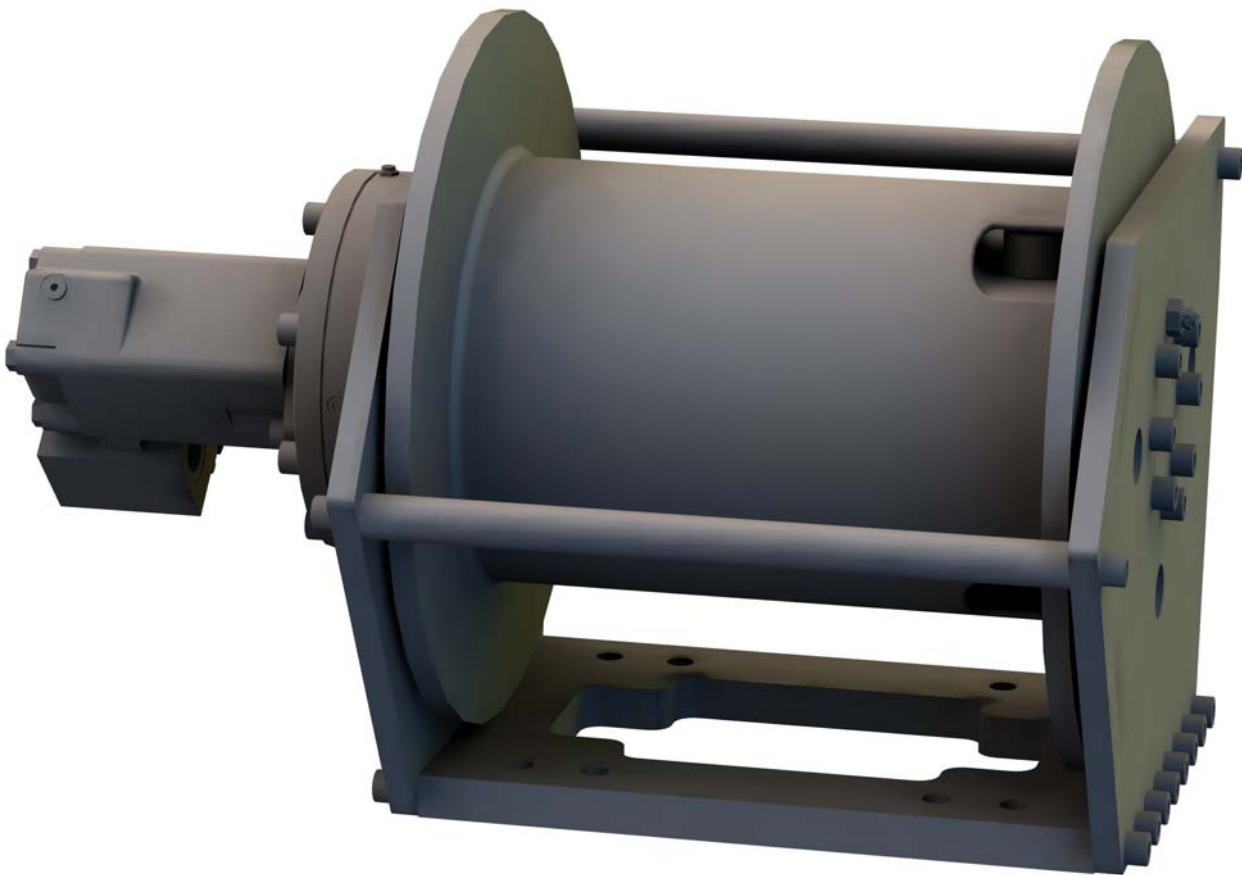

# RCH SERIES

TM

By **RAMSEY**



## RCH 12000 HOIST



**CAUTION:** READ AND UNDERSTAND THIS MANUAL BEFORE INSTALLATION AND OPERATION OF HOIST. SEE WARNINGS!

## TABLE OF CONTENTS

<b>WARNINGS.....</b>	<b>2</b>
<b>LUBRICATION TABLE.....</b>	<b>2</b>
<b>SPECIFICATIONS.....</b>	<b>3-4</b>
<b>HYDRAULIC SYSTEM REQUIREMENTS.....</b>	<b>5-6</b>
<b>CABLE INSTALLATION .....</b>	<b>7</b>
<b>HOIST OPERATION .....</b>	<b>8</b>
<b>MAINTENANCE.....</b>	<b>8</b>
<b>TROUBLE SHOOTING GUIDE.....</b>	<b>9</b>
<b>INSTRUCTIONS FOR HOIST DISASSEMBLY .....</b>	<b>10-14</b>
<b>DISASSEMBLY AND ASSEMBLY OF CARRIERS.....</b>	<b>15-20</b>
<b>HOSE HOOKUPS .....</b>	<b>22</b>
<b>PARTS DRAWINGS AND PART LISTS.....</b>	<b>23-30</b>
<b>DIMENSIONAL DRAWINGS .....</b>	<b>31-34</b>
<b>LIMITED WARRANTY .....</b>	<b>35</b>



# WARNING

Do not operate this hoist until you have carefully read and understood the "WARNINGS" and "OPERATION" sections of this manual. Failure to follow the "WARNINGS" and "OPERATION" sections in this manual may result in serious injury or death.

## **WARNINGS**

- **OPERATORS MUST BE TRAINED IN THE PROPER OPERATION OF THE HOIST.**
- **STAY OUT FROM UNDER AND AWAY FROM RAISED LOADS. FAILURE TO DO SO MAY RESULT IN SERIOUS INJURY OR DEATH.**
- **STAY AWAY FROM CABLES IN TENSION. A BROKEN CABLE MAY RESULT IN SERIOUS INJURY OR DEATH.**
- **DO NOT EXCEED MAXIMUM LINE PULL RATINGS SHOWN IN SPECIFICATION TABLES.**
- **DO NOT USE HOIST TO LIFT, SUPPORT, OR OTHERWISE TRANSPORT PEOPLE.**
- **A MINIMUM OF 5 WRAPS OF CABLE AROUND THE DRUM BARREL IS NECESSARY TO HOLD THE LOAD. CABLE ANCHOR IS NOT DESIGNED TO HOLD LOAD.**
- **AVOID SHOCK LOADS. THIS TYPE OF LOAD PUTS A STRAIN ON THE HOIST MANY TIMES THE ACTUAL WEIGHT RATED FOR THE HOIST.**
- **HOIST MUST BE PROPERLY MAINTAINED.**
- **DO NOT USE EP TYPE GEAR LUBES IN THE BRAKE SECTION OF THIS WINCH. EP LUBES MAY PREVENT THE CLUTCH FROM LOCKING UP, WHICH, IN TURN CAUSES THE LOAD TO FALL, RESULTING IN PROPERTY DAMAGE, PERSONAL INJURY, OR DEATH.**

### **PLANETARY HOIST GEARBOX OIL**

Lubricant Description*	Temp Range F(C)		
	Min Ambient & Operating	Max Ambient	Max Operating
80W140 Synthetic	-25 (-32)	125 (52)	225 (107)
75W90 Synthetic	-40 (-40)	115 (46)	215 (102)
80W90 Conventional	-20 (-29)	100 (38)	180 (82)
85W140 Conventional	20 (6)	120 (50)	200 (93)
*Use API GL-5 or EP lubricants.			

### **PLANETARY HOIST BRAKE OIL**

Lubricant Description	Temp Range F(C)		
	Min Ambient & Operating	Max Ambient	Max Operating
SAE 20W20	-10 (-23)	135 (50)	225 (107)
MOBILE 1 ATF	-40 (-40)	110 (40)	215 (102)

**SPECIFICATIONS\***

**GEAR MOTOR PERFORMANCE**

MOTOR				LAYER OF CABLE					MAX FLOW GPM	MAX PRESSURE psi	HOIST WEIGHT lb	CABLE SIZE in
				1	2	3	4	5				
2 SPEED 1.25/1.00 in	LOW SPEED	LINE SPEED	fpm	77	84	92	99	107	37	2100	520	9/16
		LINE PULL	lb	12000	10800	9800	9000	8300				
	HIGH SPEED	LINE SPEED	fpm	166	182	198	214	231				
		LINE PULL	lb	6500	5800	5300	4900	4500				
		LINE SPEED	mpm	50	55	60	65	70				
		LINE PULL	kg	2940	2630	2400	2220	2040				
SINGLE SPEED 2.25 in	LINE SPEED	LINE SPEED	fpm	153	168	183	198	213	60	2100	495	9/16
		LINE PULL	lb	12000	10800	9800	9000	8300				
	LINE PULL	kg	5440	4890	4440	4080	3760					
2 SPEED 1.00/1.00 in	LOW SPEED	LINE SPEED	fpm	84	92	100	108	116	30	2500	519	9/16
		LINE PULL	lb	12000	10800	9800	9000	8300				
	HIGH SPEED	LINE SPEED	fpm	169	185	202	218	235				
		LINE PULL	lb	6000	5400	4900	4500	4100				
		LINE SPEED	mpm	51	56	61	66	71				
		LINE PULL	kg	2720	2440	2220	2040	1850				
SINGLE SPEED 2.0 in	LINE SPEED	LINE SPEED	fpm	167	183	199	216	232	60	2500	493	9/16
		LINE PULL	lb	12000	10800	9800	9000	8300				
	LINE PULL	LINE PULL	kg	5440	4890	4440	4080	3760				
		CABLE CAPACITY	ft	55	125	195	275	360				
			m	18	38	60	84	110				

## GEROLER MOTOR PERFORMANCE

MOTOR				LAYER OF CABLE					MAX FLOW GPM	MAX PRESSURE psi	HOIST WEIGHT lb	CABLE SIZE in
				1	2	3	4	5				
2 SPEED 9.6/4.8 cu in	LOW SPEED	LINE SPEED	fpm	81	88	96	104	112	25	2750	470	9/16
			mpm	25	27	29	32	34				
		LINE PULL	lb	12000	10800	9800	9000	8300				
			kg	5440	4890	4440	4080	3760				
	HIGH SPEED	LINE SPEED	fpm	162	177	193	209	225				
			mpm	49	54	59	64	68				
		LINE PULL	lb	6000	5400	4900	4500	4100				
			kg	2720	2440	2220	2040	1850				
SINGLE SPEED 9.6 cu in	LINE SPEED	fpm	81	88	96	104	112	25	2750	460	9/16	
		mpm	25	27	29	32	34					
	LINE PULL	lb	12000	10800	9800	9000	8300					
		kg	5440	4890	4440	4080	3760					
2 SPEED 11.9/5.95 cu in	LOW SPEED	LINE SPEED	fpm	84	92	100	108	116	30	2250	470	9/16
			mpm	26	28	30	33	35				
		LINE PULL	lb	12000	10800	9800	9000	8300				
			kg	5440	4890	4440	4080	3760				
	HIGH SPEED	LINE SPEED	fpm	168	184	200	217	233				
			mpm	51	56	61	66	71				
		LINE PULL	lb	6000	5400	4900	4500	4100				
			kg	2720	2440	2220	2040	1850				
SINGLE SPEED 11.9 cu in	LINE SPEED	fpm	84	92	100	108	116	30	2250	460	9/16	
		mpm	26	28	30	33	35					
	LINE PULL	lb	12000	10800	9800	9000	8300					
		kg	5440	4890	4440	4080	3760					
CABLE CAPACITY		ft	55	125	195	275	360					
		m	18	38	60	84	110					

**NOTE:** The rated line pulls shown are for the hoist only. Consult the wire rope manufacturer for wire rope ratings.

## HYDRAULIC SYSTEM REQUIREMENTS

Refer to the performance charts, above, to properly match your hydraulic system to hoist performance.

### SINGLE SPEED GEAR MOTOR

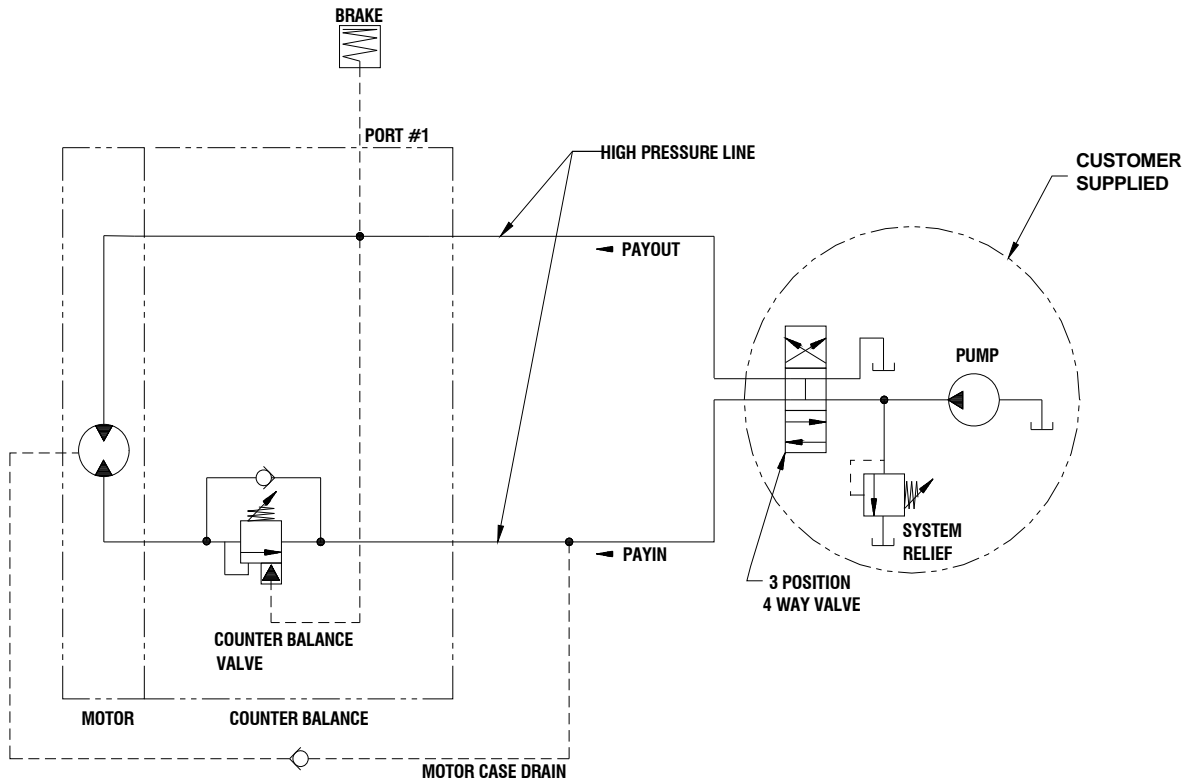

### SINGLE SPEED GEROLER MOTOR

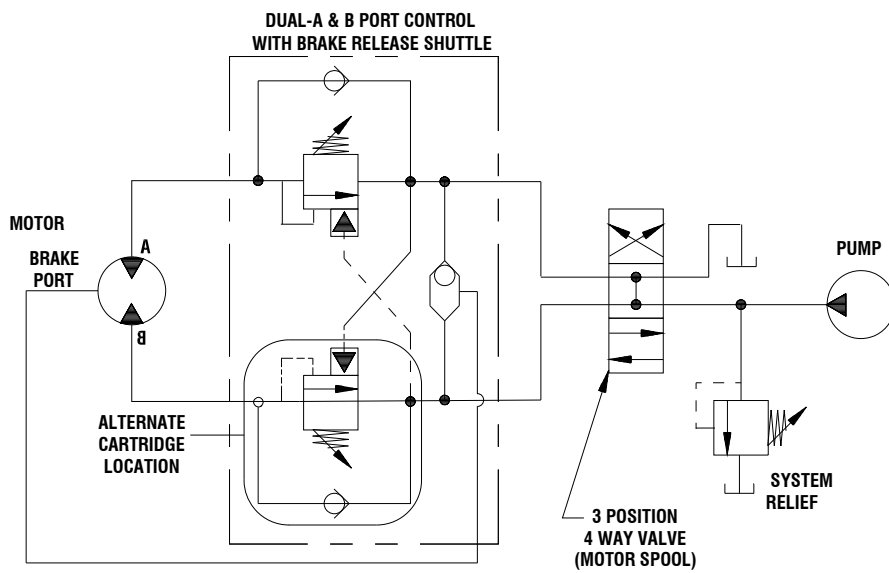

# 2 SPEED GEAR MOTOR

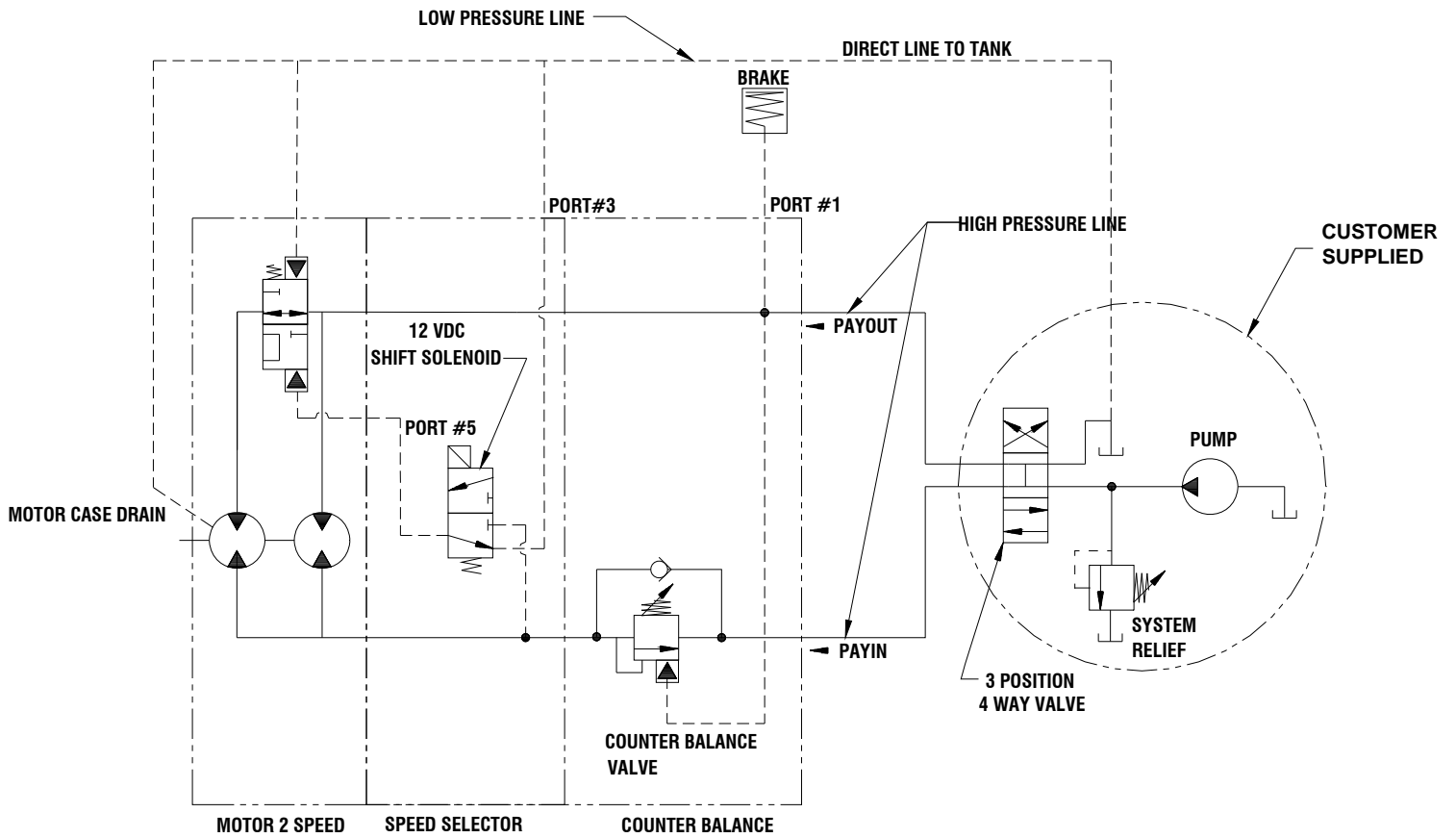

# 2 SPEED GEROLER MOTOR

(A ROTATION SHOWN)

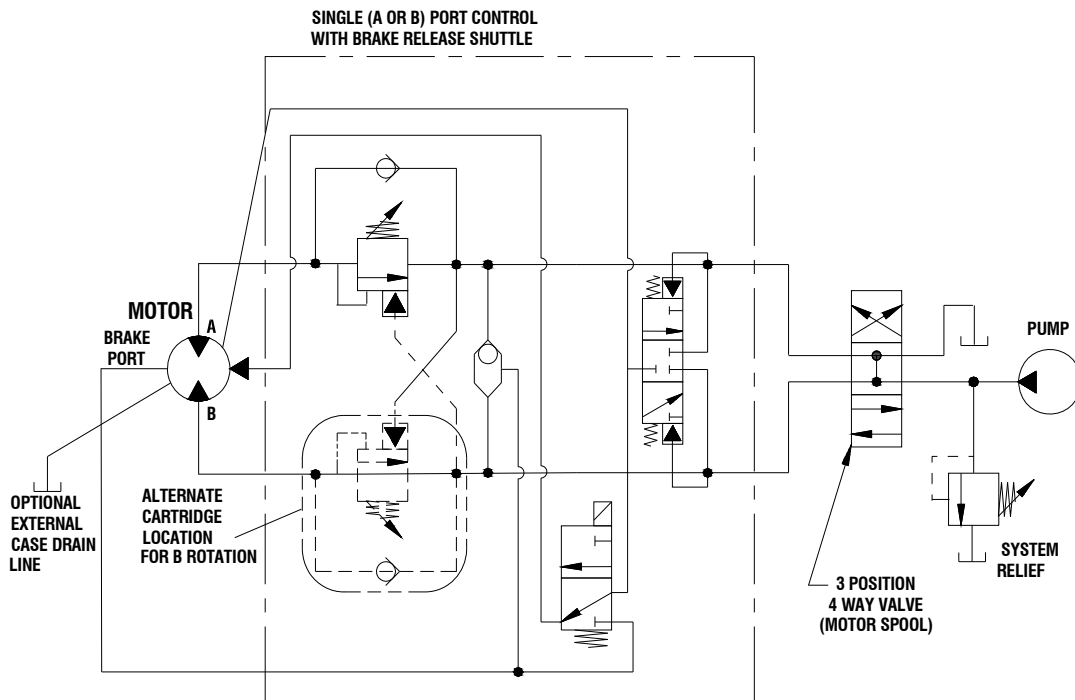

## CABLE INSTALLATION

1. Unwind cable by rolling it out along the ground to prevent kinking. Securely wrap end of wire rope, opposite hook, with plastic or similar tape to prevent fraying.
2. Slide the wire rope through narrow end of the pocket against the drum flange. Wrap the wire rope around on the anchor (item #16) and pull the wire rope and anchor back into the wide end of the pocket. Use a soft hammer to drive the back side of the wire rope, firmly seating the wire rope and anchor into the pockets
3. Carefully run the hoist in the "reel-in" direction. Keeping tension on end of cable, spool all the cable onto the cable drum, taking care to form neatly wrapped layers.

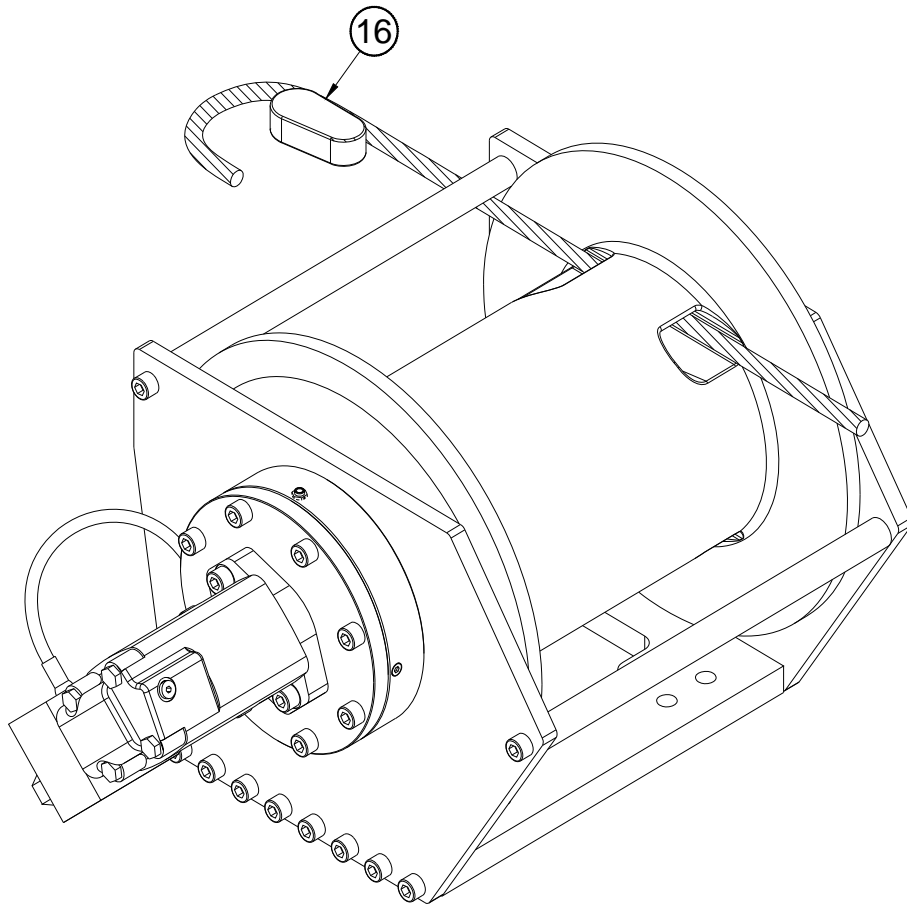



## **HOIST OPERATION**

The best way to get acquainted with how your hoist operates is to make test runs before you use it. Plan your test in advance. Remember, you hear your hoist, as well as see it operate; learn to recognize the sounds of a light steady pull, a heavy pull, and sounds caused by load jerking or shifting. Gain confidence in operating your hoist and its use will become second nature with you.

The uneven spooling of cable while pulling a load is not a problem, unless there is a cable pileup on one end of drum. If this happens reverse the hoist to relieve the load and move your anchor point further to the center of the vehicle. After the job is done you can unspool and rewind for a neat lay of the cable.

## **MAINTENANCE**

The owner is to ensure proper inspection intervals, in compliance with ANSI B30.5, 5-2.3, and will review hoist usage categories on a periodic basis. A Qualified Inspector should perform all maintenance and inspections.

- For hoist in occasional use less than 10 hours per month it is recommended a pre-use inspection and an annual 12 month inspection based on average use over a quarter.
- For hoist in moderate use, more than 10 but less than 50 hours per month, it is recommended a pre-use inspection, quarterly inspection, and an annual 12-month inspection based on average use over a quarter.
- For hoist in heavy use, more than 50 hours per month it is recommended a pre-use inspection, monthly inspection, quarterly inspection, and an annual 12 months inspection.

## TROUBLE SHOOTING GUIDE

CONDITIONS	POSSIBLE CAUSE	CORRECTION
<b>OIL LEAKS FROM HOIST</b>	<ol style="list-style-type: none"> <li>1. Seals damaged or worn.</li> <li>2. Too much oil.</li> <li>3. Damaged o-rings.</li> <li>4. Case drain not connected.</li> </ol>	<ol style="list-style-type: none"> <li>1. Replace seal</li> <li>2. Drain excess oil.</li> <li>3. Replace o-rings.</li> <li>4. Connect case drain.</li> </ol>
<b>HOIST RUNS TOO SLOW</b>	<ol style="list-style-type: none"> <li>1. Low flow rate.</li> <li>2. Hydraulic motor worn out.</li> </ol>	<ol style="list-style-type: none"> <li>1. Check flow rate. Refer to Hydraulic Systems Performance Chart, page 3,4.</li> <li>2. Replace motor.</li> </ol>
<b>BRAKE WILL NOT HOLD</b>	<ol style="list-style-type: none"> <li>1. Incorrect directional control valve (cylinder spool, closed center).</li> <li>2. Excessive hydraulic system back pressure.</li> <li>3. Sprag clutch worn out.</li> </ol>	<ol style="list-style-type: none"> <li>1. Use only a motor spool (open center) directional control valve.</li> <li>2. Reduce system back pressure to less than 100 psi.</li> <li>3. Replace sprag clutch mechanism.</li> </ol>
<b>BRAKE WILL NOT RELEASE</b>	<ol style="list-style-type: none"> <li>1. Brake line disconnected or blocked</li> </ol>	<ol style="list-style-type: none"> <li>1. Repair brake line.</li> </ol>
<b>HOIST WILL NOT OPERATE AT HIGH SPEED</b>	<ol style="list-style-type: none"> <li>1. Shift solenoid not working.</li> </ol>	<ol style="list-style-type: none"> <li>1. Verify shift spool is energized.</li> </ol>
<b>HOIST OPERATES ERRATICALLY ON INHAUL</b>	<ol style="list-style-type: none"> <li>1. Sprag hub is reversed.</li> </ol>	<ol style="list-style-type: none"> <li>1. Install sprag hub correctly.</li> </ol>

## INSTRUCTIONS FOR DISASSEMBLY

1. Remove wire rope from drum.
2. Rotating drum where both plugs #31 are visible thru side plate. Drain oil by removing both plugs and rotate drum until one plug is at the bottom of the hoist.
3. Remove plugs #30 and drain oil from brake.
4. When replacing lubricant, fill drum at plug #31 with 64oz of applicable lube for your climate from table on page 2 and fill brake at plug #30 with 16oz of applicable brake lube for your climate from table on page 38.

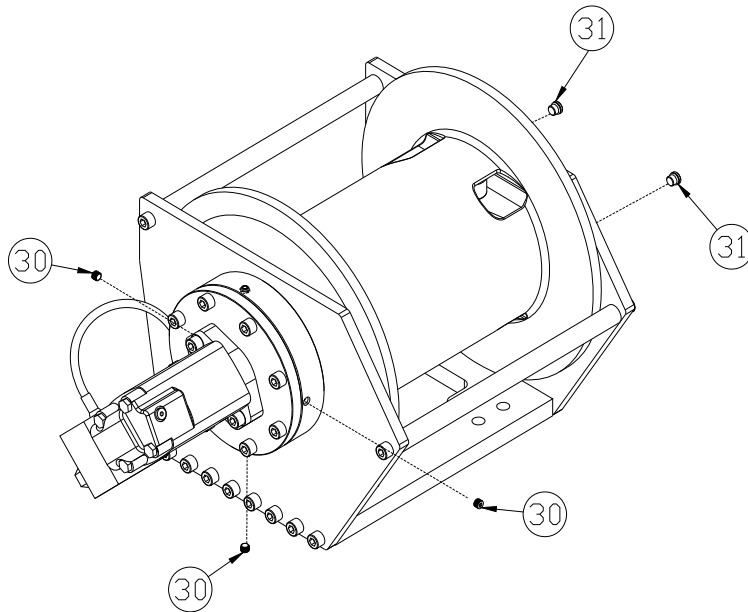

5. Disconnect brake release hose #39 from elbow fittings #22. If needed elbow fittings may be removed. Remove counterbalance valve #41 by removing (3) bolts #20. The motor #24 can be removed by removing (2) bolts #21.

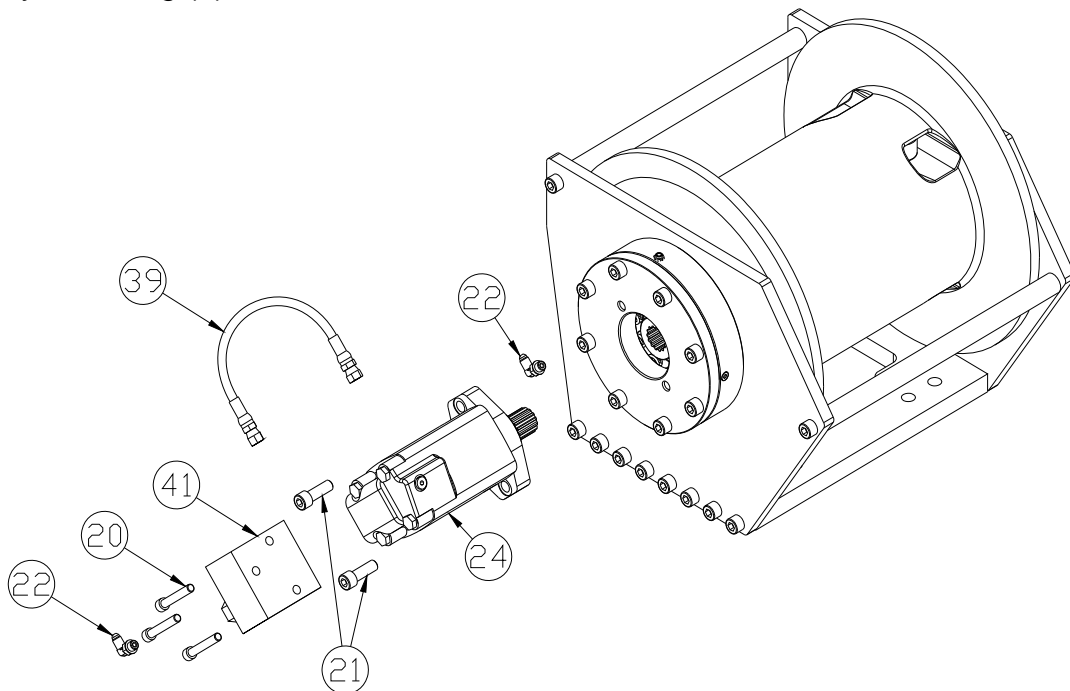

6. Remove brake cover #5 by removing (8) bolts #19. **The cover is spring loaded, use care when removing.** Remove o-ring #25 then springs #38 may be removed; residual oil may be present in the brake housing.
7. Remove piston #4 including o-rings and backup rings #26, #27, #28, and #29 by using a momentary puff of compressed air into the brake port located on top of the end bearing. Capture the piston by placing a shop rag over the opening prior to using air. Capture the piston by placing a shop rag over the opening prior to using air.
8. Remove the sprag brake hub assembly #3, (8) stator plates #6, and (7) disc brakes #7. The sprag brake hub assembly #3 is not a serviceable part, if damaged a replacement assembly should be ordered.

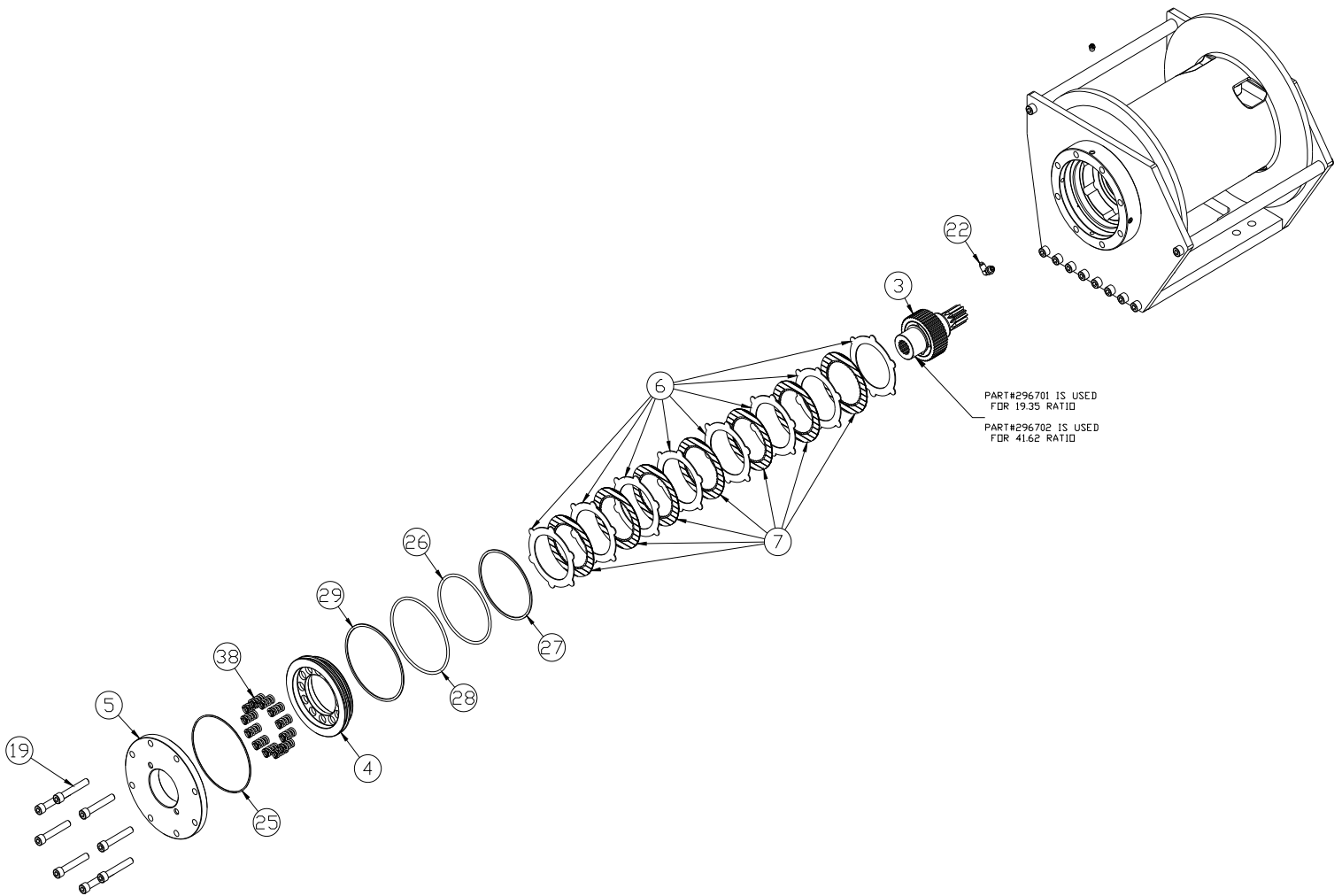

9. Remove brake housing #11 from side plate #13.
10. Remove the side plate by removing (10) bolts #21.

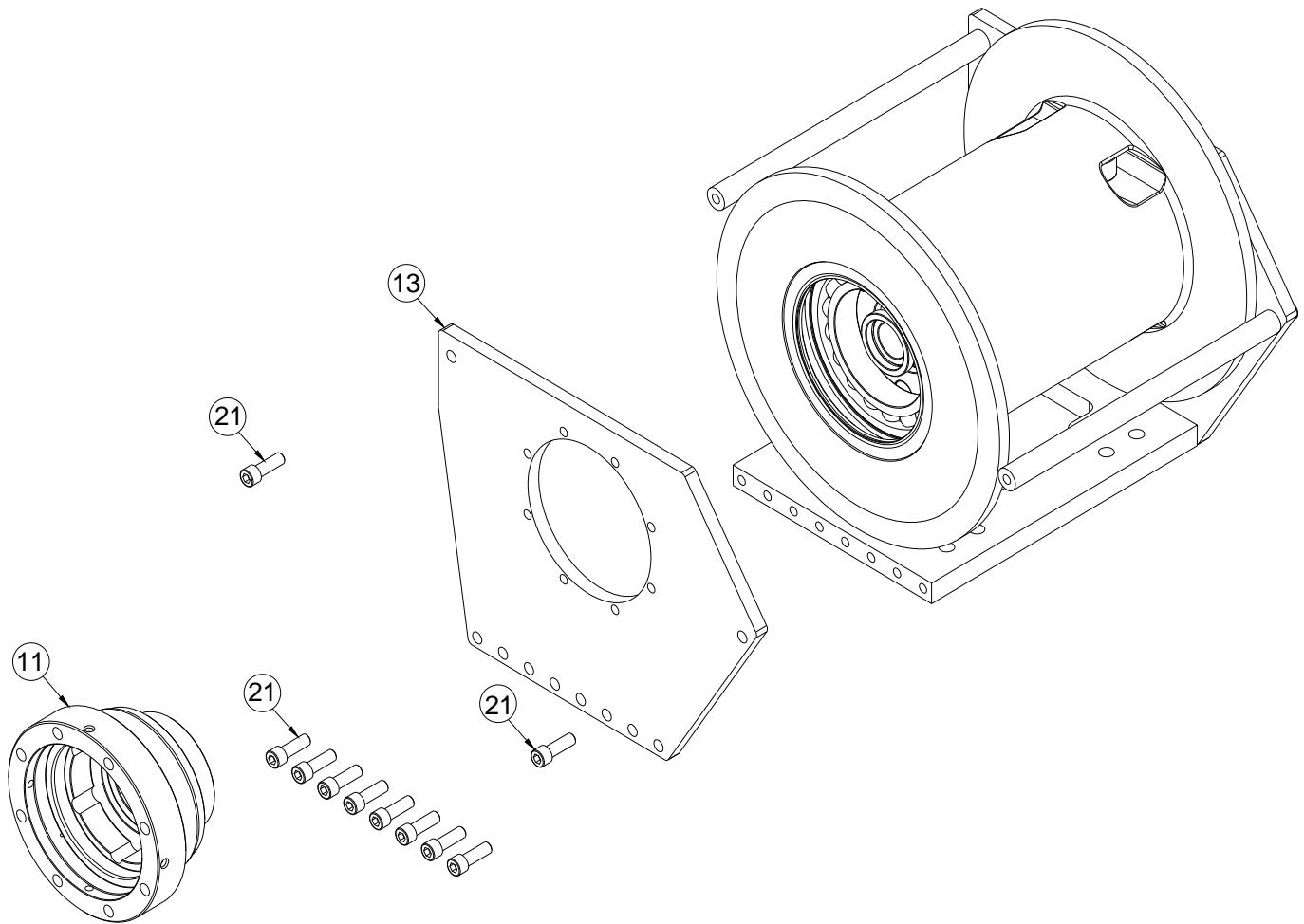

11. Remove base plate #15 and (2) tie bars #32 by removing (10) bolts #21
12. Remove side plate #14 by removing (7) bolts #21 and (1) bolt #40.
13. Seal #35 can now be removed.
14. Uninstall retaining ring #36 and then drum spacer #17 can be removed.

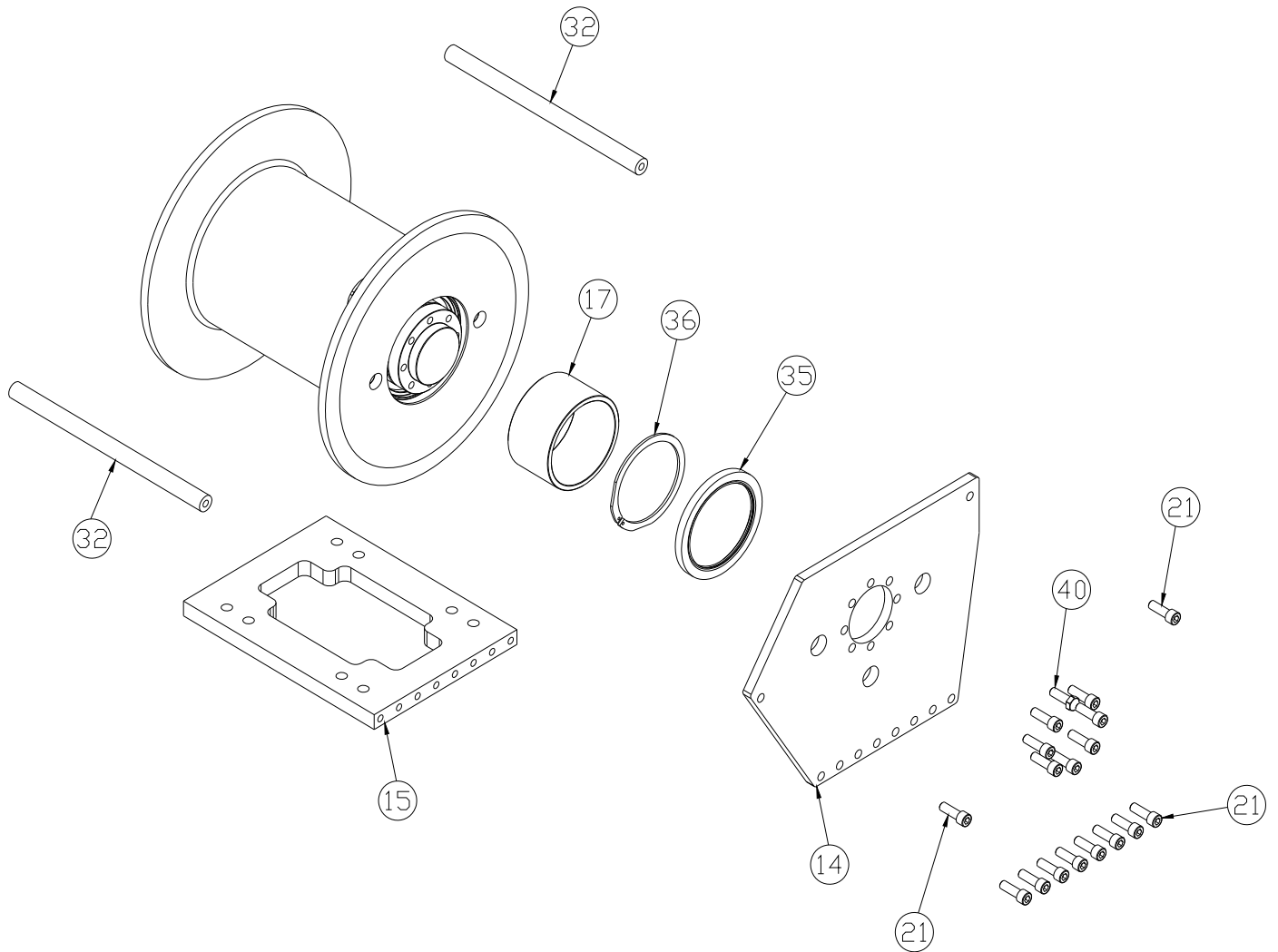

15. Remove seal #35

16. To remove bearing #12, spacer #42, input gear #10, input carrier assembly #2, and output sun #9, tap output carrier #1 with a soft hammer on the cable anchor side of drum #8

17. Uninstall retaining ring #37 then bearing#12 can be removed

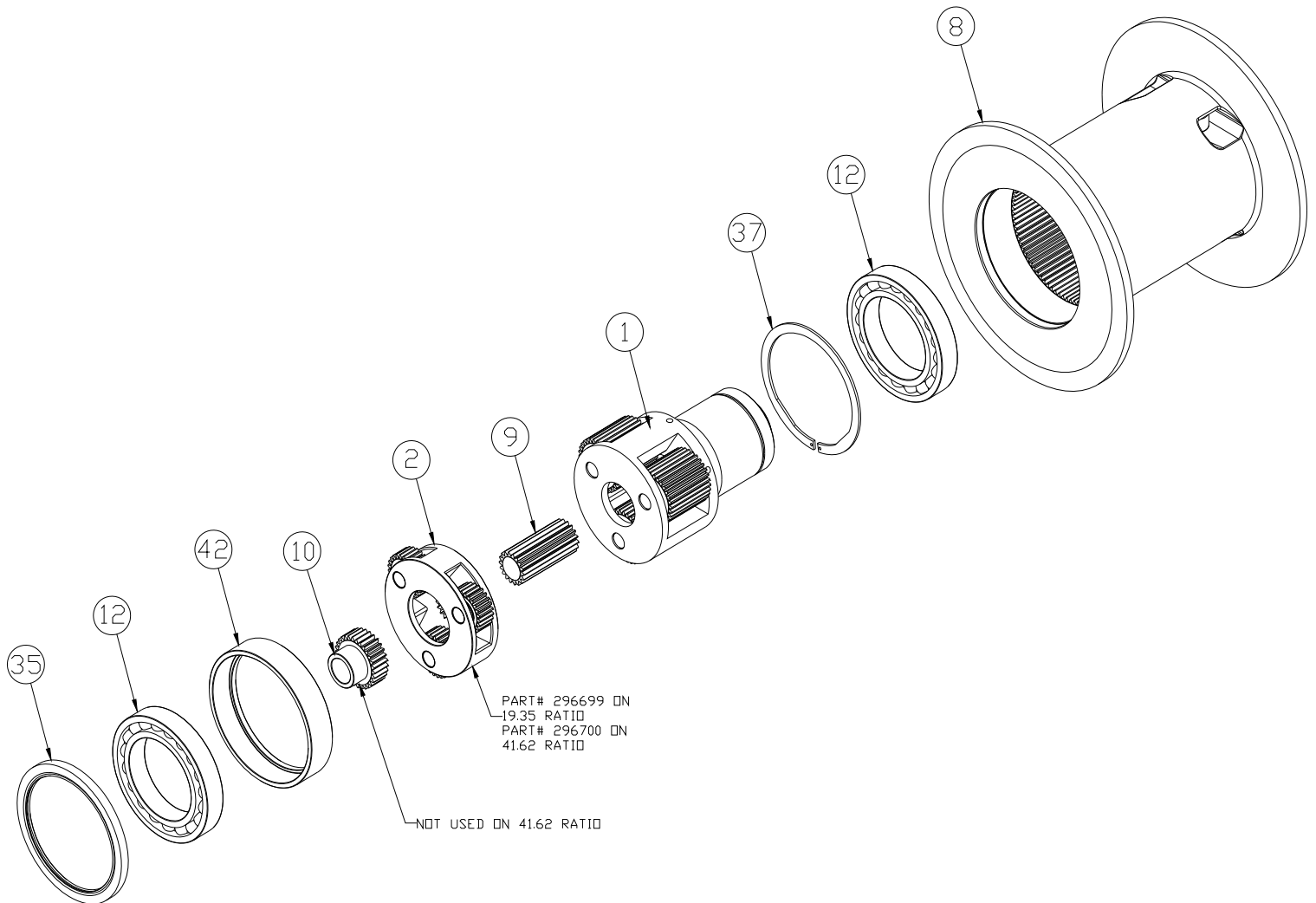

## DISASSEMBLY OF INPUT CARRIER 19.35 RATIO

Carrier assemblies may be purchased as a complete assembly (see pg. 23) or parts may be purchased individually (see parts list below). If purchasing individual parts, it will be necessary to disassemble the input gear carrier as outlined below.

1. Carefully drive roll pin #65 into carrier pin #63 so that it is captured within carrier pin #63 but not touching the opposite side of the input carrier #60.
2. Tap carrier pin #63 to remove it from the input carrier #60.
3. Slide the planet gear #51 and the (2) thrust washers #54 from the carrier assembly #60. Bearing #62 may then be pressed out.
4. Remove the roll pin #65 from the carrier pin #63.

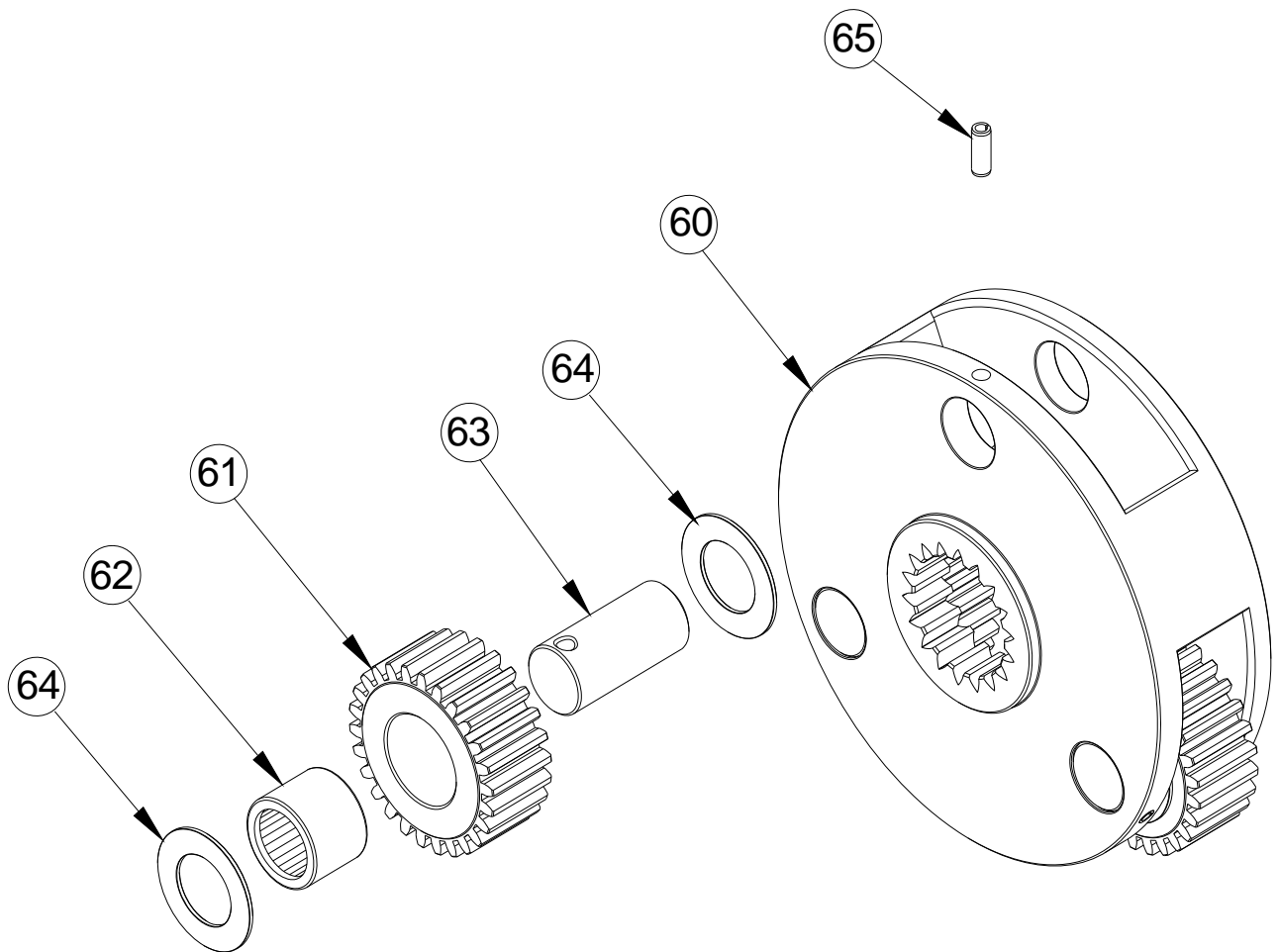

ITEM #	QTY	PART #	DESCRIPTION
60	1	317030	CARRIER-INPUT
61	3	334214	GEAR-INPUT-PLANET
62	3	402138	BEARING-NEEDEL
63	3	470119	PIN-INPUT
64	6	518069	WASHER-THRUST
65	3	470086	SPRING PIN-1/4 X 11/16 LG



## ASSEMBLY OF INPUT CARRIER 19.35 RATIO

**Note: Item Numbers refer to Carrier parts list on page 15**

1. Place carrier #60 on flat clean surface.
2. Place the gear #61 on a flat thin clean metal plate; Align the bearing with the chamfer facing toward the gear. Using a press, press the bearing flush to the gear surface.
3. Place thrust washer #64 on top of gear #61. Insert carrier pin #63 into carrier #60, aligning roll pin #65 with the matching hole on the carrier #60.
4. Insert a thrust washer between gear #61 and carrier #60. Completely insert carrier pin #63 into carrier #60 using care to align the roll pin hole in carrier pin #63 with the roll pin hole in the carrier #60.
5. Drive roll pin #65 into carrier #60 until roll pin #65 is  $\frac{1}{4}$ " past flush with surface of the carrier #60.
6. Repeat this process to install the two remaining gears into the carrier.

## DISASSEMBLY OF INPUT CARRIER 41.62 RATIO

Carrier assemblies may be purchased as a complete assembly (see pg. 27) or parts may be purchased individually (see parts list below). If purchasing individual parts, it will be necessary to disassemble the input gear carrier as outlined below.

1. Carefully drive roll pin #71 into carrier pin #69 so that it is captured within carrier pin #69 but not touching the opposite side of the input carrier #66.
2. Tap carrier pin #69 to remove it from the input carrier #66.
3. Slide the planet gear #67 and the (2) thrust washers #70 from the carrier assembly #66. Bearing #68 may then be pressed out.
4. Remove the roll pin #71 from the carrier pin #69.

ITEM #	QTY	PART #	DESCRIPTION
66	1	317031	MACHINED-CARRIER-INPUT RCH
67	3	334215	GEAR-INPUT-PLANET-RCH
68	3	402138	BEARING-NEEDEL RCH
69	3	470119	PIN-INPUT RCH
70	6	518069	WASHER-THRUST RCH
71	3	470121	SPRING PIN-1/4 X 7/8 LG

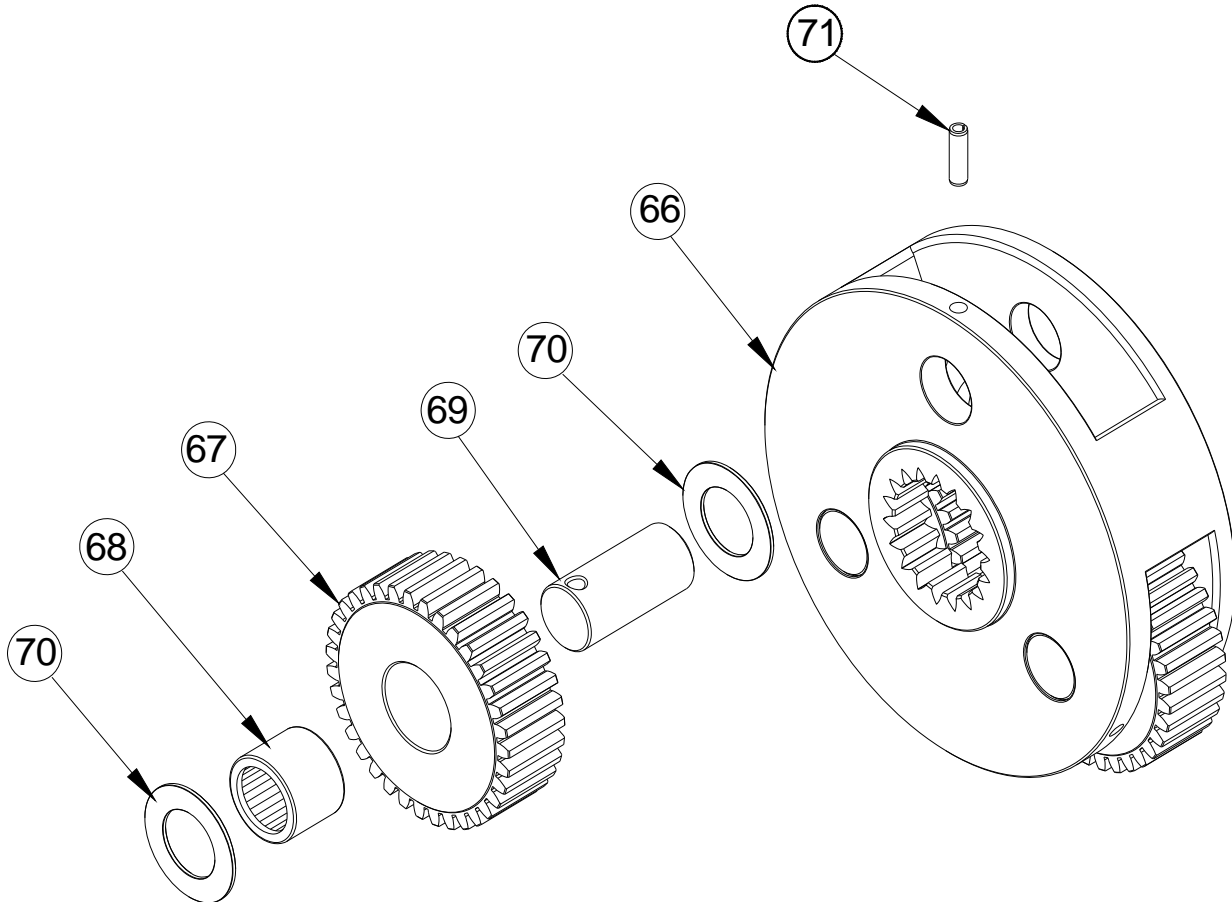

## ASSEMBLY OF INPUT CARRIER 41.62 RATIO

**Note: Item Numbers refer to Carrier parts list on page 17**

1. Place carrier #66 on flat clean surface.
2. Place the gear #67 on a flat thin clean metal plate; Align the bearing with the chamfer facing toward the gear. Using a press, press the bearing flush to the gear surface.
3. Place thrust washer #70 on top of gear #67. Insert carrier pin #69 into carrier #66, aligning roll pin #71 with the matching hole on the carrier #66.
4. Insert a thrust washer between gear #67 and carrier #66. Completely insert carrier pin #69 into carrier #66 using care to align the roll pin hole in carrier pin #69 with the roll pin hole in the carrier #66.
5. Drive roll pin #71 into carrier #66 until roll pin #71 is  $\frac{1}{4}$ " past flush with surface of the carrier #66.
6. Repeat this process to install the two remaining gears into the carrier.

## DISASSEMBLY OF OUTPUT CARRIER

Carrier assemblies may be purchased as a complete assembly (see pg. 23) or parts may be purchased individually (see below). If purchasing individual parts, it will be necessary to disassemble the gear carrier as outlined below.

1. Carefully drive roll pin #76 into carrier pin #72 so that it is captured within carrier pin #75 but not touching the opposite side of the output carrier #72.
2. Tap carrier pin #75 to remove it from the output carrier #72.
3. Slide the gear #73 from the carrier #72
4. Press bearings #77, from the gear #73
5. Remove the roll pin #76 from the carrier pin #75.
6. Repeat this process for the two remaining gears in the carrier.
7. Remove spacer #78 from the carrier #72

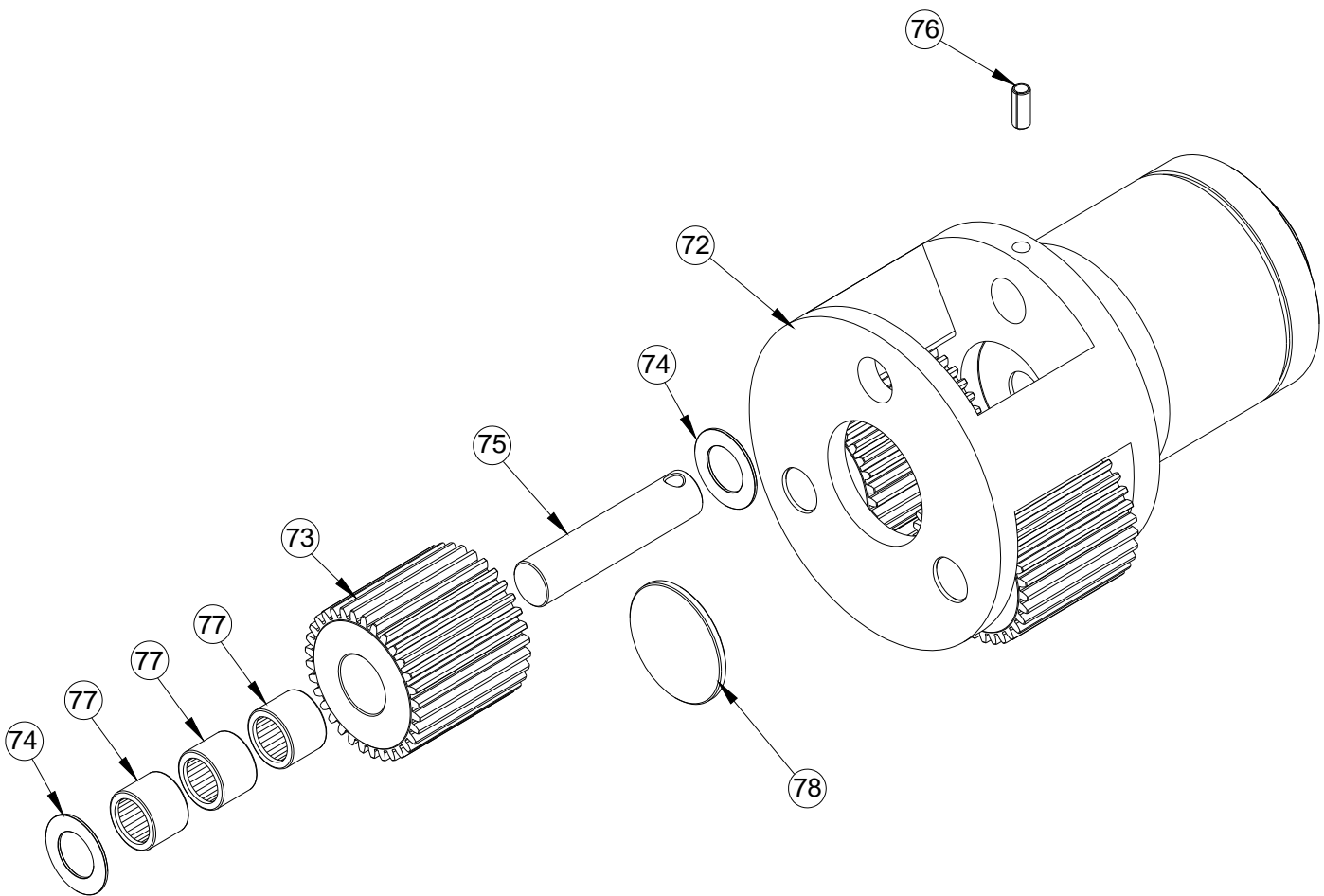

ITEM #	QTY	PART #	DESCRIPTION
72	1	317014	OUTPUT CARRIER
73	3	334210	PLANET GEAR
74	6	518069	THRUST WASHER
75	3	470118	CARRIER PIN
76	3	470120	ROLL PIN 3/8 DIA X 7/8 LG
77	9	402138	BEARING-NEEDLE ROLLER
78	1	408386	SPACER

## **ASSEMBLY OF OUTPUT CARRIER**

**Note: Item Numbers refer to Carrier parts list on page 19**

1. Place output carrier #56 on flat clean surface.
2. Install spacer #62 into the carrier
3. Press in (3) Bearings #61 into gear #57. Repeat this process to install the bearings in the two remaining gears.
4. Slide the gear #57 into position in the output carrier #56.
5. Insert a thrust washer between gear #57 and output carrier #56. Completely insert carrier pin #59 into carrier #56 using care to align the roll pin hole in carrier pin #59 with the roll pin hole in the output carrier #56.
6. Drive roll pin #60 into output carrier #56 until roll pin #60 is flush with surface of the output carrier #56.
7. Repeat this process to install the two remaining gears into the output carrier.

# NOTES

**RCH 12000 HOSE HOOKUP  
41.62 RATIO SINGLE SPEED**

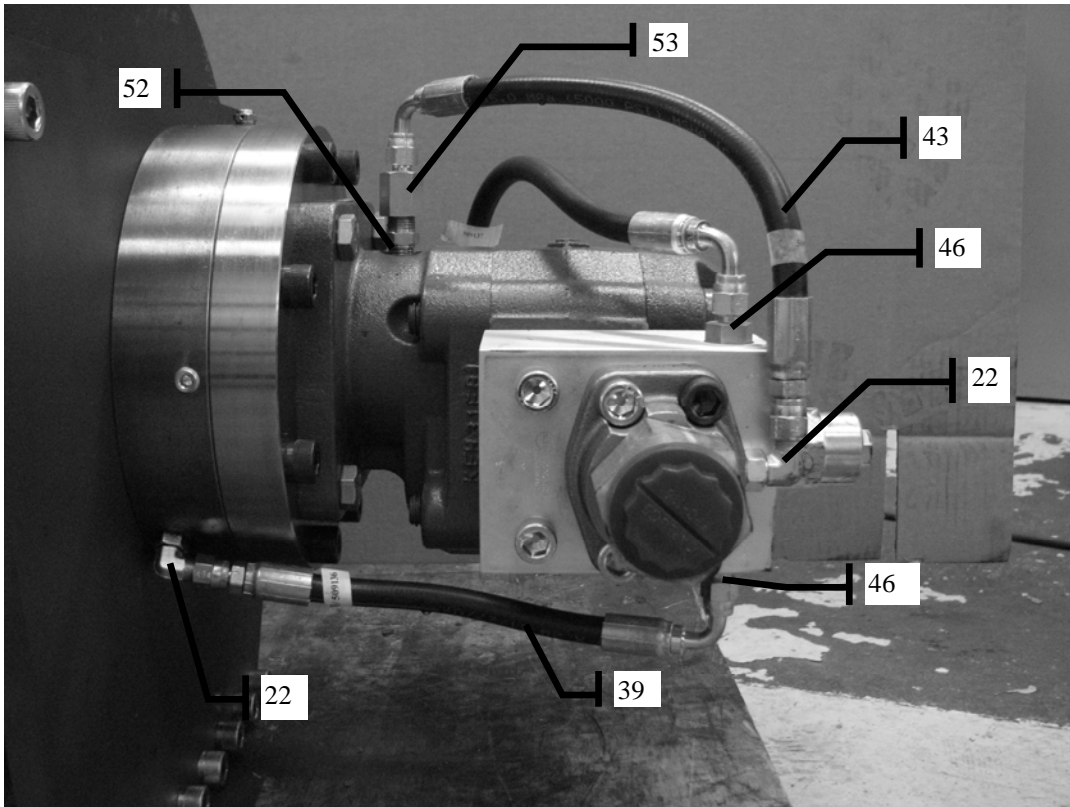
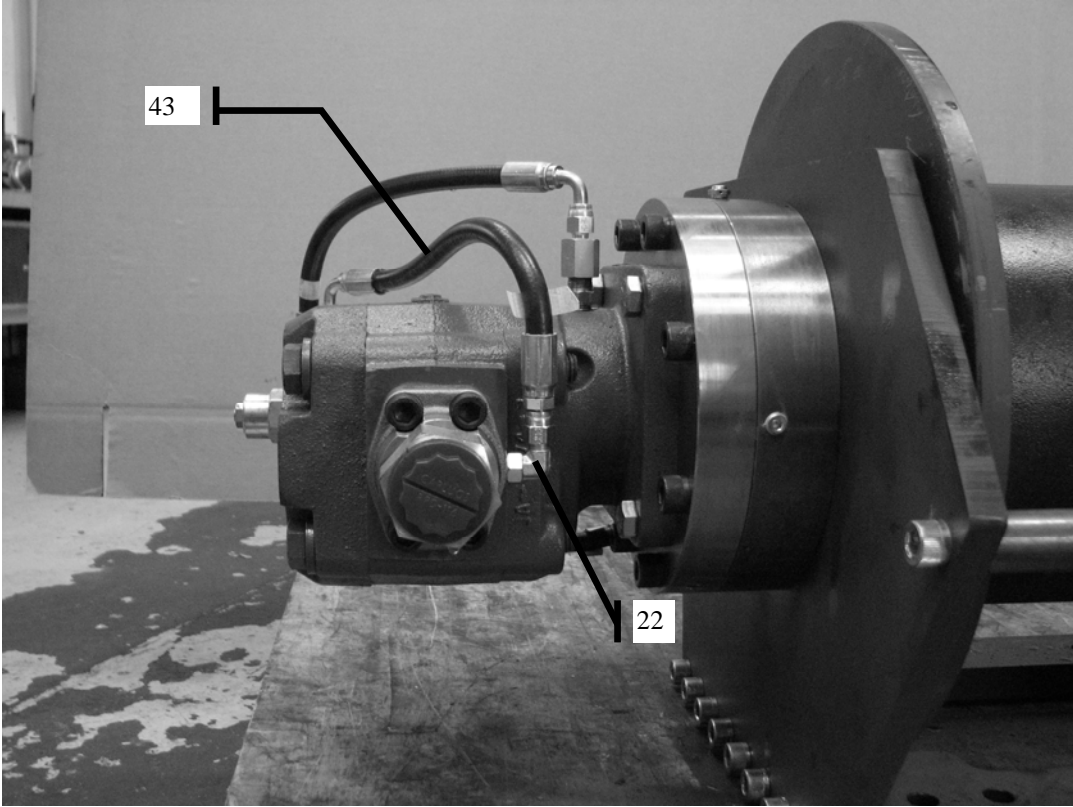

**RCH 12000 PARTS DRAWING**  
**19.35 RATIO SINGLE SPEED**

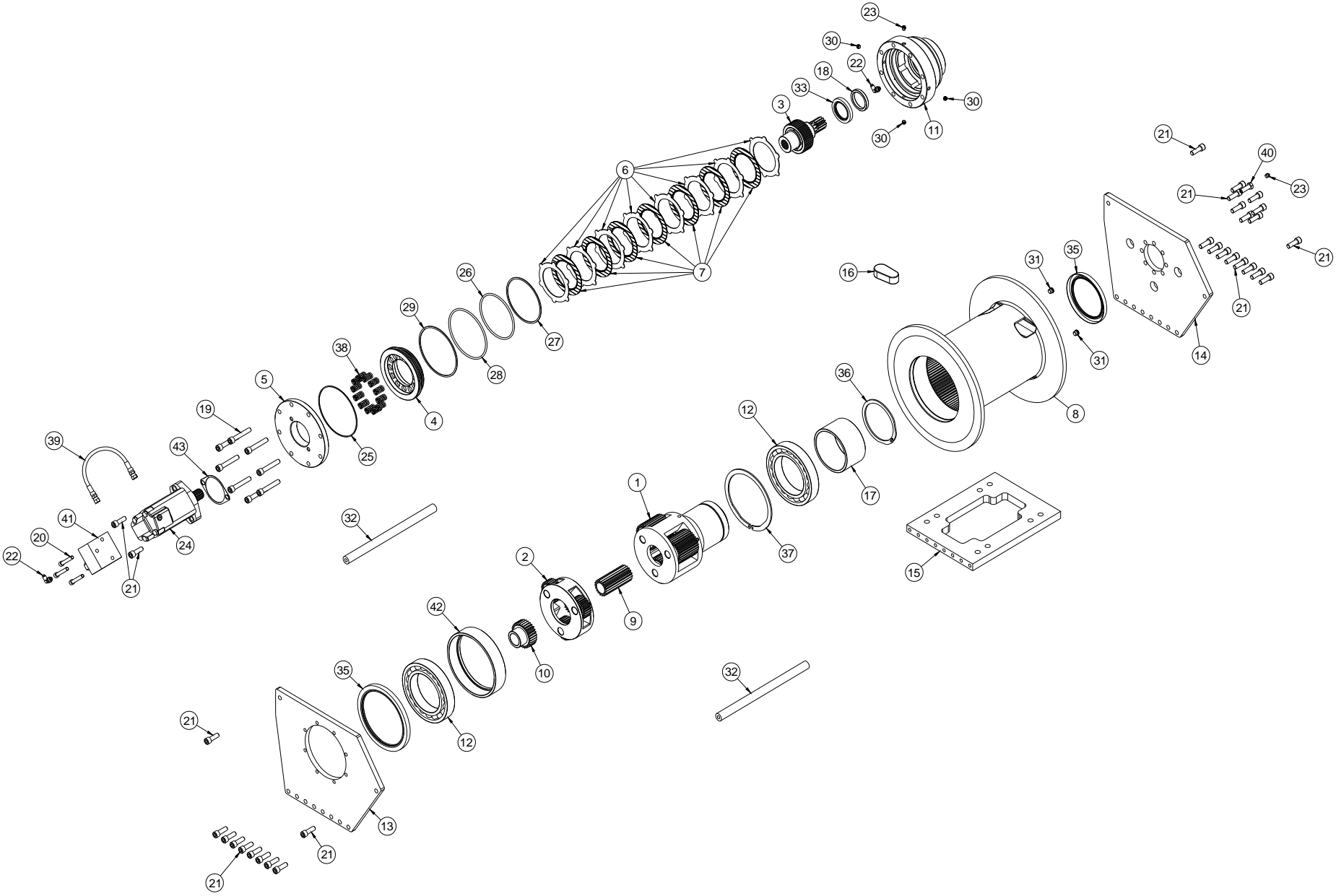



**RCH 12000 PARTS LIST  
19.35 RATIO SINGLE SPEED**

ITEM	QTY	PART NO	DESCRIPTION
1	1	296698	ASSY-PLANETARY OUTPUT
2	1	296699	ASSY PLANETARY INPUT
3	1	296701	ASSY-BRAKE HUB SPRAG
4	1	306043	BRAKE PISTON
5	1	328169	BRAKE COVER
6	8	330017	STATOR PLATE-BRAKE
7	7	330018	FRICITION PLATE-BRAKE
8	1	332257	CABLE DRUM
9	1	334211	GEAR-OUTPUT-SUN
10	1	334213	GEAR-INPUT-SUN
11	1	338384	BRAKE-HSG-MACHINED RCH
12	2	402137	BEARING-BALL-DRUM RCH
13	1	408383	SIDE PLATE-INPUT RCH
14	1	408384	SIDE PLATE-OUTPUT RCH
15	1	408385	PLATE-BASE RCH
16	1	408387	WEDGE CABLE-RCH
17	1	412126	SPACER-DRUM RCH
18	1	412128	BUSHING-BRAKE RCH
19	8	414517	CAPSCREW-1/2-13X3.0 LG SOC HD
20	3	414935	CAPSCREW-3/8-16NCX4,HXHD
21	29	414952	CAPSCREW-1/2-13NCX1 1/2LG,SOCHD,Z/P
22	2	432018	FITTING- 7/16-20 90 degree

ITEM	QTY	PART NO	DESCRIPTION
23	2	456008	RELIEF FIT-1/8-27PFT,BALL CHECK,Z/P
24	1	458151	MOTOR- 9.6 CU.IN.
		458173	MOTOR- 11.9 CU.IN.
25	1	462063	O-RING-AS-568-165
26	1	462082	O-RING 2-358
27	1	462083	BACKUP RING 8-357
28	1	462084	O-RING 2-362
29	1	462085	BACKUP RING 8-362
30	3	468016	PIPE PLUG-1/8-27NPTF,HEX SOC. HD. Z/P
31	2	468043	PLUG,-5 SAE, 1/2"-20 UNF
32	2	474226	TIE BAR RCH
33	1	486089	SEAL-SHAFT OIL
34	1	486090	SEAL-SHAFT OIL
35	1	486091	SEAL-SHAFT OIL
36	1	490059	RING-RETAINING-DIN 471-130
37	1	490060	RING RETAINING DIN 472-200
38	12	494129	SPRING-BRAKE- 385LB IN/IN
39	1	509130	HOSE ASSY-HYD BRAKE RELEASE
40	1	514019	CAPSCREW-1/2-13 UNC X 1.50 LG - SPECIAL
41	1	516014	VALVE-MOTOR CONTROL
42	1	518068	SPACER-BEARING-DRUM
43	1	442223	GASKET SAE "A" 2 BOLT MOTOR FLANGE

**RCH 12000 PARTS DRAWING**  
**19.35 RATIO 2 SPEED**

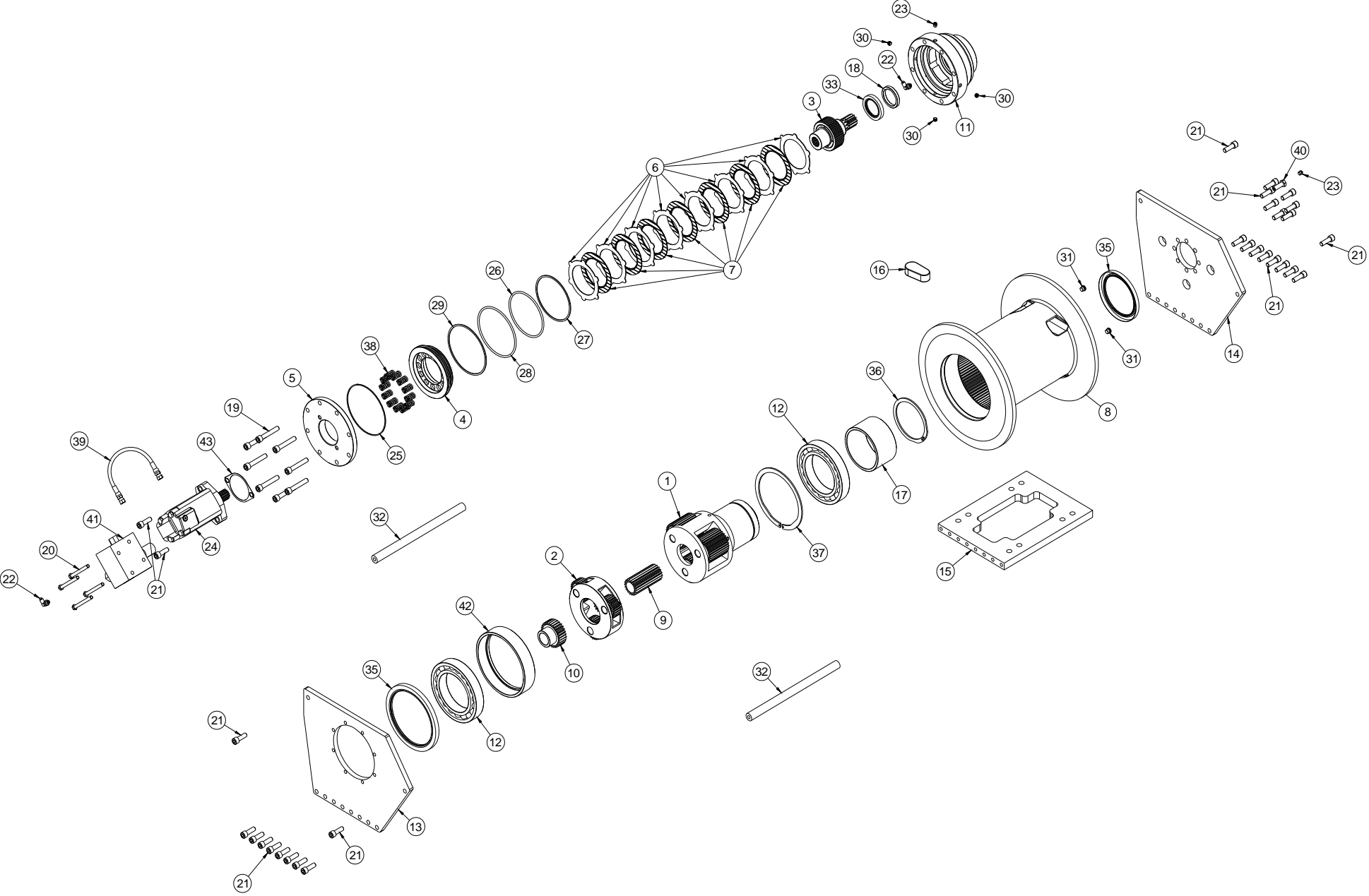

**RCH 12000 PARTS LIST**  
**19.35 RATIO 2 SPEED**

ITEM	QTY	PART NO	DESCRIPTION
1	1	296698	ASSY-PLANETARY OUTPUT
2	1	296699	ASSY PLANETARY INPUT
3	1	296701	ASSY-BRAKE HUB SPRAG
4	1	306043	BRAKE PISTON
5	1	328169	BRAKE COVER
6	8	330017	STATOR PLATE-BRAKE
7	7	330018	FRICTION PLATE-BRAKE
8	1	332257	CABLE DRUM
9	1	334211	GEAR-OUTPUT-SUN
10	1	334213	GEAR-INPUT-SUN
11	1	338384	BRAKE-HSG-MACHINED RCH
12	2	402137	BEARING-BALL-DRUM RCH
13	1	408383	SIDE PLATE-INPUT RCH
14	1	408384	SIDE PLATE-OUTPUT RCH
15	1	408385	PLATE-BASE RCH
16	1	408387	WEDGE CABLE-RCH
17	1	412126	SPACER-DRUM RCH
18	1	412128	BUSHING-BRAKE RCH
19	8	414517	CAPSCREW-1/2-13X3.0 LG SOC HD
20	4	414400	CAPSCREW-3/8-16NCX4,HXHD
21	29	414952	CAPSCREW-1/2-13NCX1 1/2LG,SOCHD,Z/P
22	2	432018	FITTING- 7/16-20 90 degree

ITEM	QTY	PART NO	DESCRIPTION
23	2	456008	RELIEF FIT-1/8-27PFT,BALL CHECK,Z/P
24	1	458153	MOTOR- 9.6 CU.IN., 2 SPEED
		458174	MOTOR- 11.9 CU.IN., 2 SPEED
25	1	462063	O-RING-AS-568-165
26	1	462082	O-RING 2-358
27	1	462083	BACKUP RING 8-357
28	1	462084	O-RING 2-362
29	1	462085	BACKUP RING 8-362
30	3	468016	PIPE PLUG-1/8-27NPTF,HEX SOC. HD. Z/P
31	2	468043	PLUG,-5 SAE, 1/2"-20 UNF
32	2	474226	TIE BAR
33	1	486089	SEAL-SHAFT OIL
34	1	486090	SEAL-SHAFT OIL
35	1	486091	SEAL-SHAFT OIL
36	1	490059	RING-RETAINING-DIN 471-130
37	1	490060	RING RETAINING DIN 472-200
38	12	494129	SPRING-BRAKE- 385LB IN/IN
39	1	509130	HOSE ASSY-HYD BRAKE RELEASE
40	1	514019	CAPSCREW-1/2-13 UNC X 1.50 LG - SPECIAL
41	1	516036	VALVE-MOTOR CONTROL
42	1	518068	SPACER-BEARING-DRUM
43	1	442223	GASKET SAE "A" 2 BOLT MOTOR FLANGE

**RCH 12000 PARTS DRAWING**  
**41.62 RATIO SINGLE SPEED**

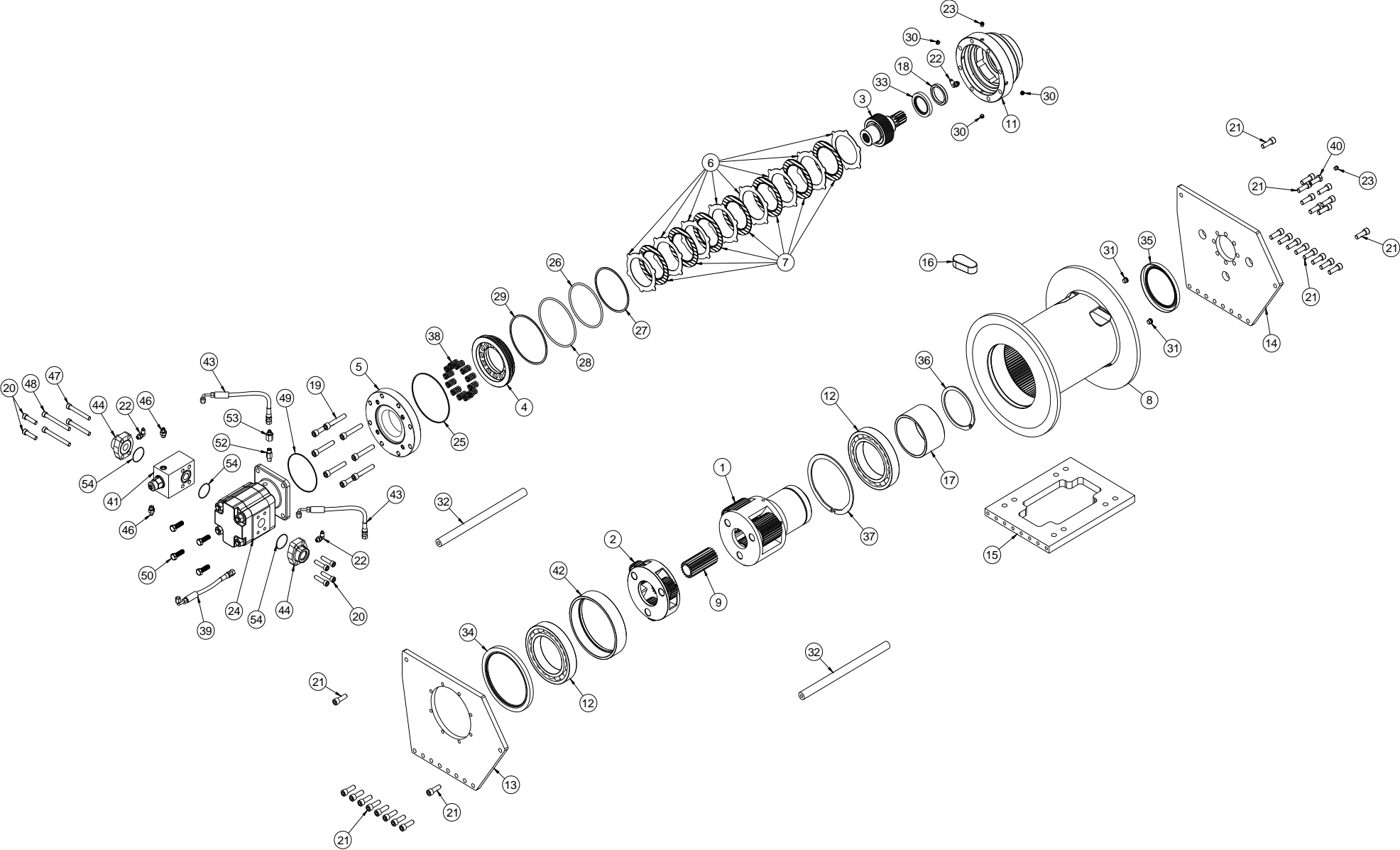

**RCH 12000 PARTS LIST**  
**41.62 RATIO SINGLE SPEED**

ITEM	QTY	PART NO	DESCRIPTION	ITEM	QTY	PART NO	DESCRIPTION
1	1	296698	ASSY-PLANETARY OUTPUT	27	1	462083	BACKUP RING 8-357
2	1	296700	ASSY PLANETARY INPUT	28	1	462084	O-RING 2-362
3	1	296702	ASSY-BRAKE HUB SPRAG	29	1	462085	BACKUP RING 8-362
4	1	306043	BRAKE PISTON	30	3	468016	PIPE PLUG-1/8-27NPTF,HEX SOC. HD. Z/P
5	1	328171	BRAKE COVER RCH	31	2	468043	PLUG,-5 SAE, 1/2"-20 UNF
6	8	330017	STATOR PLATE-BRAKE	32	2	474226	TIE BAR RCH
7	7	330018	FRICITION PLATE-BRAKE	33	1	486089	SEAL-SHAFT OIL
8	1	332257	CABLE DRUM	34	1	486090	SEAL-SHAFT OIL
9	1	334211	GEAR-OUTPUT-SUN	35	1	486091	SEAL-SHAFT OIL
10			NOT USED	36	1	490059	RING-RETAINING-DIN 471-130
11	1	338384	BRAKE-HOUSING	37	1	490060	RING RETAINING DIN 472-200
12	2	402137	BALL BEARING-DRUM	38	12	494129	SPRING-BRAKE- 385LB IN/IN
13	1	408383	SIDE PLATE-INPUT	39	1	509136	HOSE ASSY-HYD BRAKE RELEASE
14	1	408384	SIDE PLATE-OUTPUT	40	1	514019	SPECIAL CAPSCREW-1/2-13 UNC X 1.50 LG HX HD GR8 Z/P
15	1	408385	PLATE-BASE	41	1	516046	VALVE-MOTOR CONTROL
16	1	408387	WEDGE CABLE	42	1	518068	SPACER-BEARING-DRUM
17	1	412126	SPACER-DRUM	43	2	509137	HOSE ASSEMBLY
18	1	412128	BUSHING-BRAKE	44	2	432061	SAE 1.313-12 FLANGE MOUNT WITH -4 PORT
19	8	414595	CAPSCREW-1/2-13 X 3.5 LG SOC HD	46	2	432051	COUPLING STRAIGHT THREAD 37DEG FLARE SAE ORB
20	2	414431	CAPSCREW -7/16-14 X 1.75 LG. SOC HD.	47	2	414432	CAPSCREW -7/16-14 X 3.50 LG. SOC HD.
21	27	414952	CAPSCREW-1/2-13NCX1 1/2LG,SOC HD,Z/P	48	2	414434	CAPSCREW-7/16-14 X 4.25 LG SOC HD
22	2	432018	FITTING Parker#4-C5OX-S T-LOK, 7/16-20 90 degree	49	1	462081	O-RING 2-159
23	2	456008	RELIEF FIT-1/8-27PFT,BALL CHECK,Z/P	50	4	414512	CAPSCREW-1/2-13 X 1.5 LG HX HD GR8 Z/P
24	1	458155	MOTOR- 2.25 GEAR SECTION	51	2	432057	FITTING-INDUSTRIAL STRAIGHT THREAD
		458157	MOTOR- 2.00 GEAR SECTION	52	1	432056	CHECK VALVE-INLINE
25	1	462063	O-RING-AS-568-165	53	1	432055	FITTING-INDUSTRIAL TUBE TO PIPE
26	1	462082	O-RING 2-358	54	3	462099	O-RING 2-222

# RCH 12000 PARTS DRAWING

## 41.62 RATIO 2 SPEED

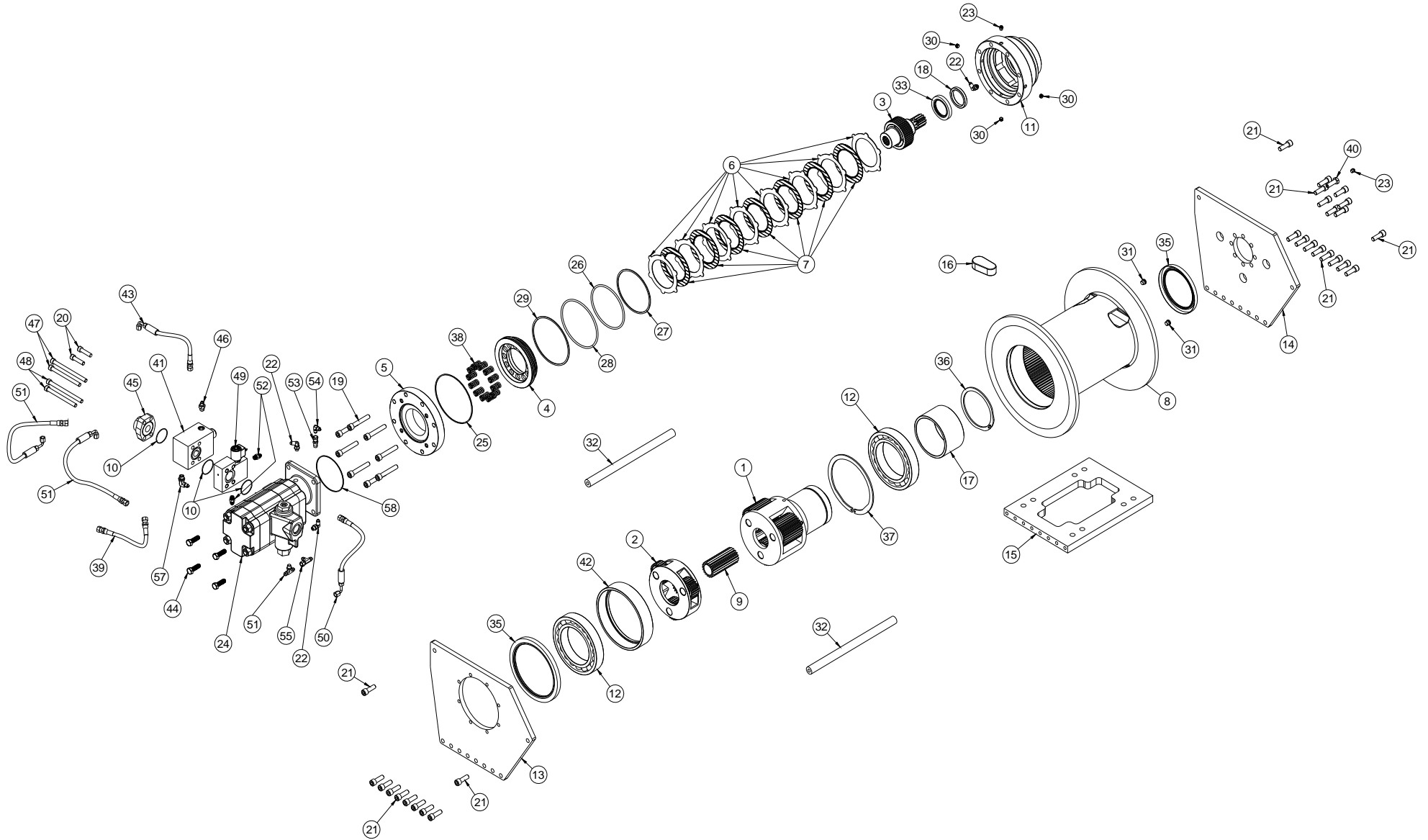

**RCH 12000 PARTS LIST****41.62 RATIO 2 SPEED**

<b>ITEM</b>	<b>QTY</b>	<b>PART NO</b>	<b>DESCRIPTION</b>	<b>ITEM</b>	<b>QTY</b>	<b>PART NO</b>	<b>DESCRIPTION</b>
1	1	296698	ASSY-PLANETARY OUTPUT	29	1	462085	BACKUP RING 8-362
2	1	296700	ASSY PLANETARY INPUT	30	3	468016	PIPE PLUG-1/8-27NPTF,HEX SOC. HD. Z/P
3	1	296702	ASSY-BRAKE HUB SPRAG	31	2	468043	PLUG,-5 SAE, 1/2"-20 UNF
4	1	306043	BRAKE PISTON	32	2	474226	TIE BAR RCH
5	1	328171	BRAKE COVER RCH	33	1	486089	SEAL-SHAFT OIL
6	8	330017	STATOR PLATE-BRAKE	34	1	486090	SEAL-SHAFT OIL
7	7	330018	FRICION PLATE-BRAKE	35	1	486091	SEAL-SHAFT OIL
8	1	332257	CABLE DRUM	36	1	490059	RING-RETAINING-DIN 471-130
9	1	334211	GEAR-OUTPUT-SUN	37	1	490060	RING RETAINING DIN 472-200
10	3	462099	O-RING 2-222	38	12	494129	SPRING-BRAKE- 385LB IN/IN
11	1	338384	BRAKE-HOUSING	39	1	509138	HOSE ASSY-HYD BRAKE RELEASE
12	2	402137	BALL BEARING-DRUM	40	1	514019	SPECIAL CAPSCREW-1/2-13 UNC X 1.50 LG HX HD GR8 Z/P
13	1	408383	SIDE PLATE-INPUT	41	1	516046	VALVE-MOTOR CONTROL
14	1	408384	SIDE PLATE-OUTPUT	42	1	518068	SPACER-BEARING-DRUM
15	1	408385	PLATE-BASE	43	1	509140	HOSE ASSEMBLY
16	1	408387	WEDGE CABLE	44	4	414512	CAPSCREW-1/2-13 X 1.50 LG HX HD GR8 Z/P
17	1	412126	SPACER-DRUM	45	1	432060	SAE 1.313-12 FLANGE MOUNT
18	1	412128	BUSHING-BRAKE	46	1	432051	COUPLING STRAIGHT THREAD 37DEG FLARE SAE ORB
19	8	414438	CAPSCREW-1/2-13X 3.5 LG SOC HD	47	2	414435	CAPSCREW -7/16-14 X 5.00 LG SOC HD
20	2	414431	CAPSCREW -7/16-14 X 1.75 LG. SOC HD.	48	2	414436	CAPSCREW 7/16-14-5.75 LG SOC HD.
21	27	414952	CAPSCREW-1/2-13NCX1 1/2LG,SOCHD,Z/P	49	1	516057	2 SPD SHIFT BLOCK
22	2	432018	FITTING Parker#4-C5OX-S T-LOK, 7/16-20 90 degree	50	1	509139	HOSE ASSEMBLY
23	2	456008	RELIEF FIT-1/8-27PFT,BALL CHECK,Z/P	51	2	509141	HOSE ASSEMBLY
24	1	458154	MOTOR-1.00 & 1.25 GEAR SECTIONS	52	2	432023	FITTING-7/16-20,PARKER#0503-4-4/EQ
		458156	MOTOR-1.00 & 1.00 GEAR SECTIONS	53	1	432046	SWIVEL CONNECTOR 37 DEG SWIVEL / NPTF
25	1	462063	O-RING-AS-568-165	54	1	432047	UNION ELBOW 37 DEG FLARE / 37 DEG. FLARE
26	1	462082	O-RING 2-358	55	1	432048	TEE SWIVEL NUT RUN 37 DEG FLARE
27	1	462083	BACKUP RING 8-357	56	1	432049	TEE STRAIGHT THREAD BRANCH 37DEG FLARE SAE ORB
28	1	462084	O-RING 2-362	57	1	432052	MALE 90 DEG. ELBOW -37 DEG FLARE / SAE-ORB
				58	1	462081	O-RING 2-159

**12K 19.35 RATIO 9.6/11.9 CU.IN DIMENSIONAL DRAWING**

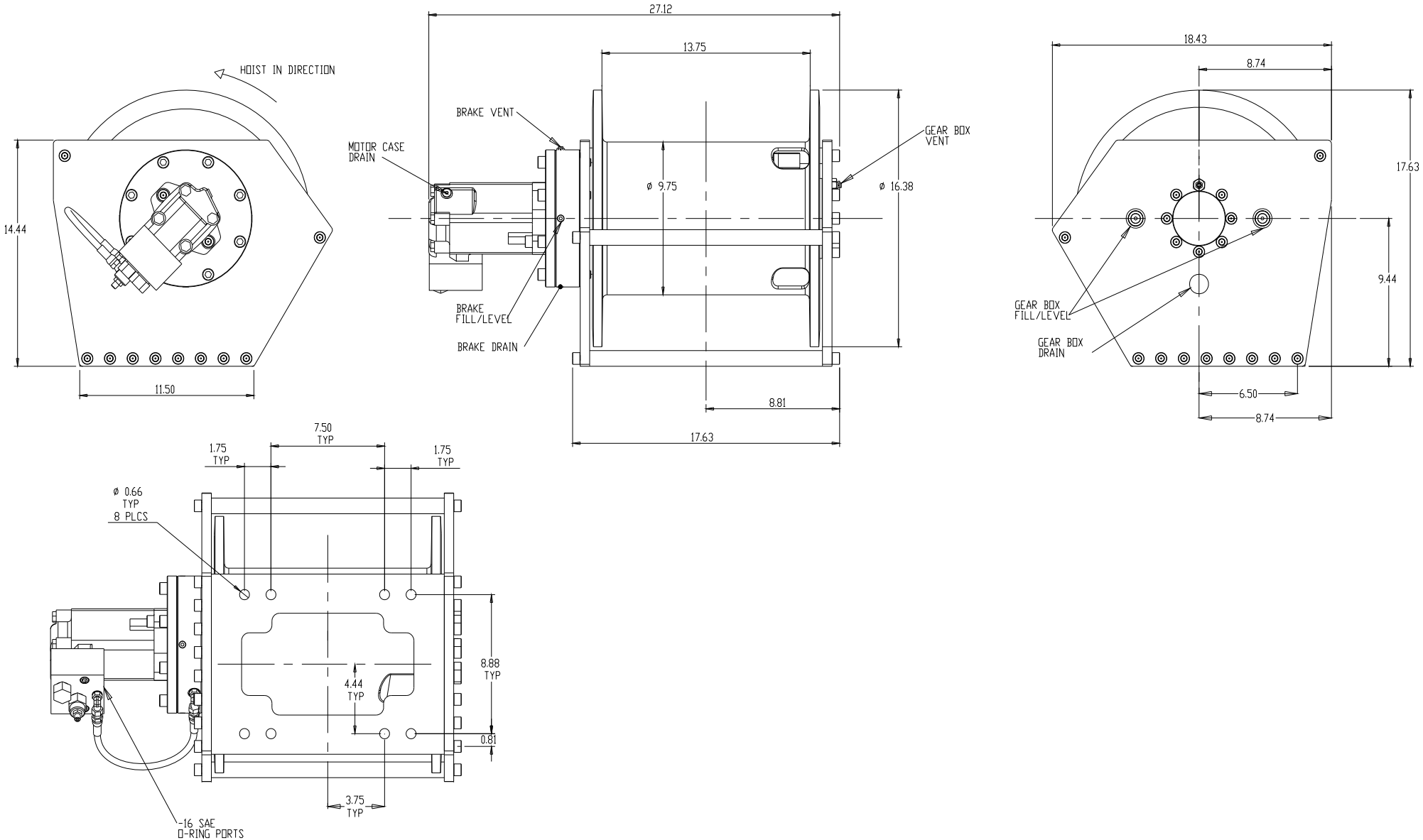



**12K 19.35 RATIO 9.6/11.9 CU.IN 2 SPEED DIMENSIONAL DRAWING**

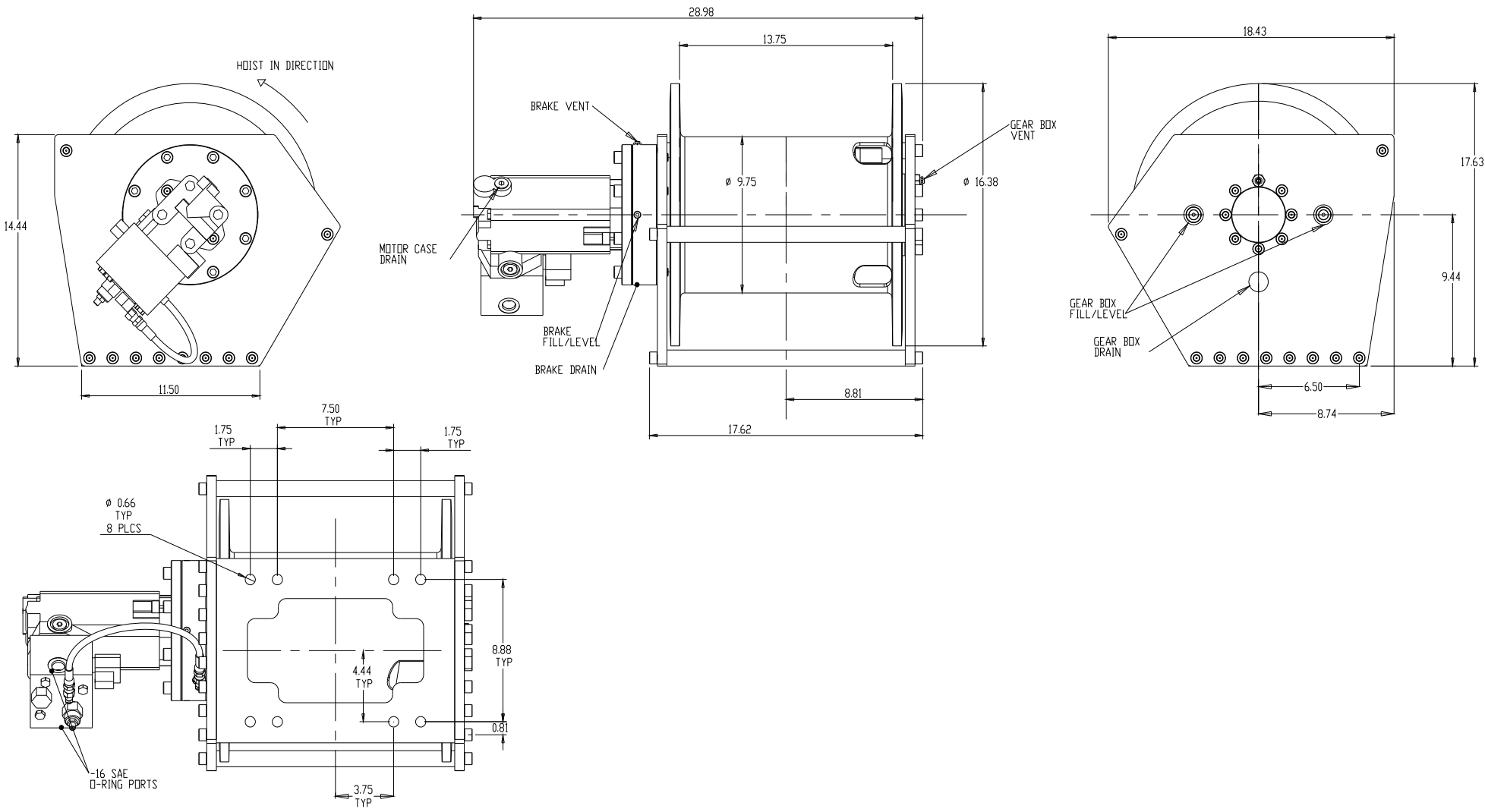

# 12K 41.62 RATIO 2.0 IN / 2.25 IN SINGLE SPEED DIMENSIONAL DRAWING

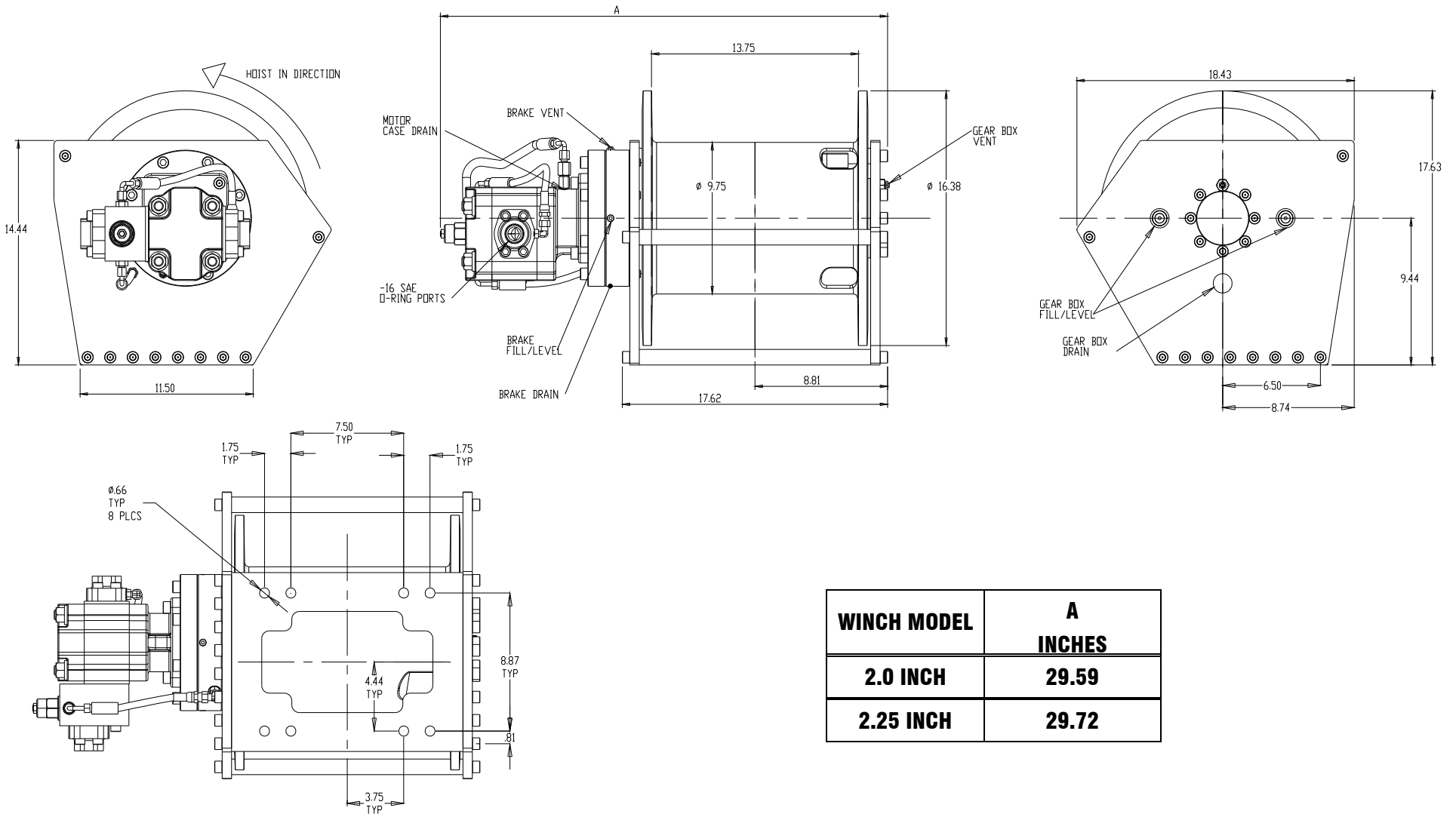

WINCH MODEL	A INCHES
2.0 INCH	29.59
2.25 INCH	29.72

# 12K 41.62 RATIO 1.00&1.00 IN / 1.25&1.00 IN 2 SPEED DIMENSIONAL DRAWING

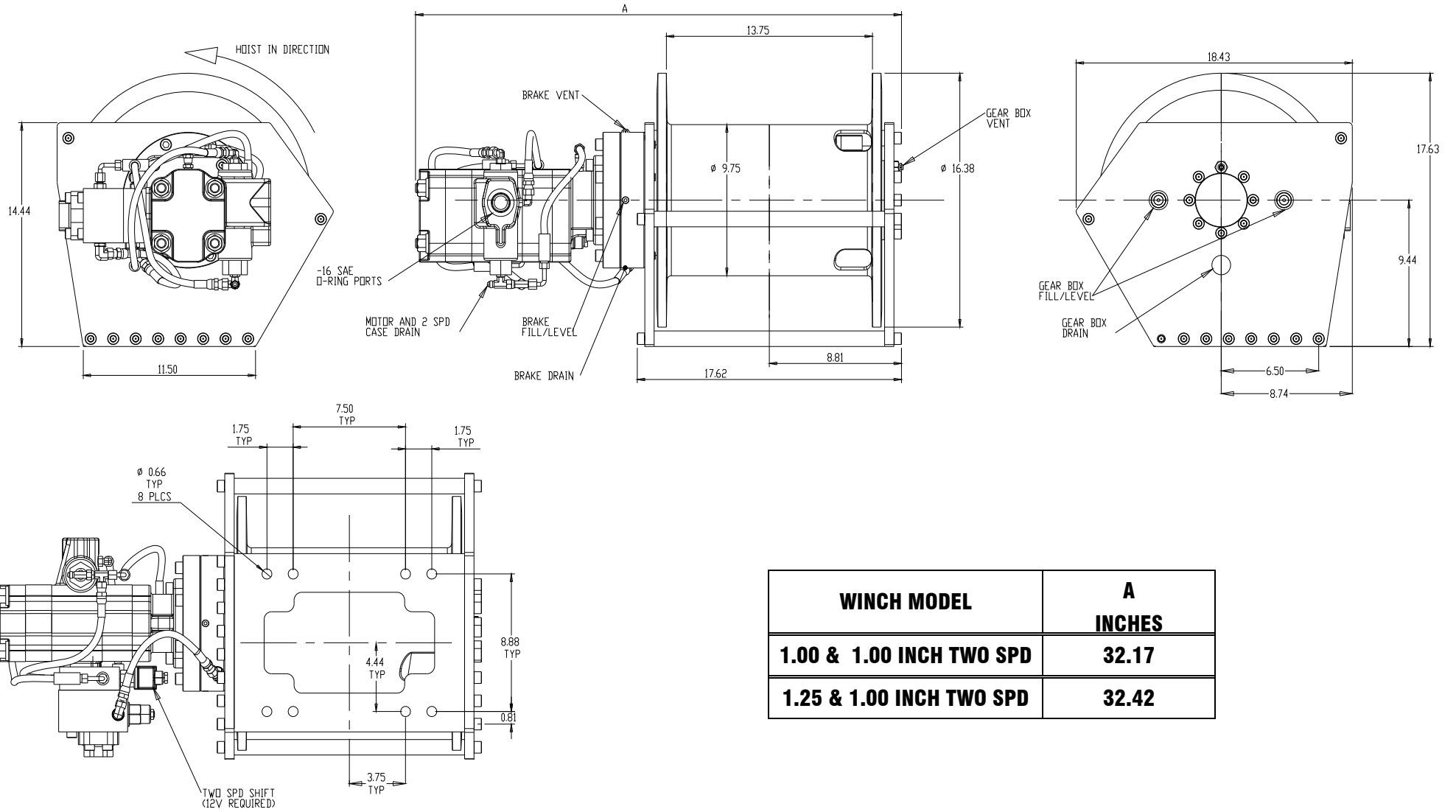

WINCH MODEL	A INCHES
1.00 & 1.00 INCH TWO SPD	32.17
1.25 & 1.00 INCH TWO SPD	32.42

## LIMITED WARRANTY

RAMSEY WINCH warrants each new RAMSEY WINCH to be free from defects in material and workmanship for a period of one (1) year from date of purchase.

The obligation under this warranty, statutory or otherwise, is limited to the replacement or repair at the Manufacturer's factory, or at a point designated by the Manufacturer, of such part that shall appear to the Manufacturer, upon inspection of such part, to have been defective in material or workmanship.

This warranty does not obligate RAMSEY WINCH to bear the cost of labor or transportation charges in connection with the replacement or repair of defective parts, nor shall it apply to a product upon which repair or alterations have been made, unless authorized by Manufacturer, or for equipment misused, neglected or which has not been installed correctly.

RAMSEY WINCH shall in no event be liable for special or consequential damages. RAMSEY WINCH makes no warranty in respect to accessories such as being subject to the warranties of their respective manufacturers.

RAMSEY WINCH, whose policy is one of continuous improvement, reserves the right to improve its products through changes in design or materials as it may deem desirable without being obligated to incorporate such changes in products of prior manufacture.

If field service at the request of the Buyer is rendered and the fault is found not to be with RAMSEY WINCH's product, the Buyer shall pay the time and expense to the field representative. Bills for service, labor or other expenses that have been incurred by the Buyer without approval or authorization by RAMSEY WINCH will not be accepted.

*See warranty card for details.*



## RAMSEY WINCH COMPANY

Post Office Box 581510

Tulsa, Oklahoma 74158-1510

Telephone: (#918) 438-2760 FAX: (#918) 438-6688

OM-914229-0611-B