



By **RAMSEY**



RCH 15000 HOIST



CAUTION: READ AND UNDERSTAND THIS MANUAL BEFORE INSTALLATION AND OPERATION OF HOIST. SEE WARNINGS!

TABLE OF CONTENTS

WARNINGS.....	2
LUBRICATION TABLE.....	2
SPECIFICATIONS.....	3
HYDRAULIC SYSTEM REQUIREMENTS.....	4-5
CABLE INSTALLATION	6
HOIST OPERATION	7
MAINTENANCE.....	7
TROUBLE SHOOTING GUIDE.....	8
INSTRUCTIONS FOR HOIST DISASSEMBLY	9-15
DISASSEMBLY AND ASSEMBLY OF CARRIERS.....	16-19
HOSE HOOKUPS	20
PARTS DRAWINGS + PART LISTS	21-26
DIMENSIONAL DRAWINGS	27-29
LIMITED WARRANTY	31



WARNING

Do not operate this hoist until you have carefully read and understood the "WARNINGS" and "OPERATION" sections of this manual. Failure to follow the "WARNINGS" and "OPERATION" sections in this manual may result in serious injury or death.

WARNINGS

- OPERATORS MUST BE TRAINED IN THE PROPER OPERATION OF THE HOIST.
- STAY OUT FROM UNDER AND AWAY FROM RAISED LOADS. FAILURE TO DO SO MAY RESULT IN SERIOUS INJURY OR DEATH.
- STAY AWAY FROM CABLES IN TENSION. A BROKEN CABLE MAY RESULT IN SERIOUS INJURY OR DEATH.
- DO NOT EXCEED MAXIMUM LINE PULL RATINGS SHOWN IN SPECIFICATION TABLES.
- DO NOT USE HOIST TO LIFT, SUPPORT, OR OTHERWISE TRANSPORT PEOPLE.
- A MINIMUM OF 5 WRAPS OF CABLE AROUND THE DRUM BARREL IS NECESSARY TO HOLD THE LOAD. CABLE ANCHOR IS NOT DESIGNED TO HOLD LOAD.
- AVOID SHOCK LOADS. THIS TYPE OF LOAD PUTS A STRAIN ON THE HOIST MANY TIMES THE ACTUAL WEIGHT RATED FOR THE HOIST.
- HOIST MUST BE PROPERLY MAINTAINED.
- DO NOT USE EP TYPE GEAR LUBES IN THE BRAKE SECTION OF THIS WINCH. EP LUBES MAY PREVENT THE CLUTCH FROM LOCKING UP, WHICH, IN TURN CAUSES THE LOAD TO FALL, RESULTING IN PROPERTY DAMAGE, PERSONAL INJURY, OR DEATH.

PLANETARY HOIST GEARBOX OIL

Lubricant Description*	Temp Range F(C)		
	Min Ambient & Operating	Max Ambient	Max Operating
80W140 Synthetic	-25 (-32)	125 (52)	225 (107)
75W90 Synthetic	-40 (-40)	115 (46)	215 (102)
80W90 Conventional	-20 (-29)	100 (38)	180 (82)
85W140 Conventional	20 (6)	120 (50)	200 (93)
*Use API GL-5 or EP lubricants.			

PLANETARY HOIST BRAKE OIL

Lubricant Description	Temp Range F(C)		
	Min Ambient & Operating	Max Ambient	Max Operating
SAE 20W20	-10 (-23)	135 (50)	225 (107)
MOBILE 1 ATF	-40 (-40)	110 (40)	215 (102)

GEAR MOTOR PERFORMANCE

MOTOR				LAYER OF CABLE					MAX FLOW GPM	MAX PRESSURE psi	HOIST WEIGHT lb	CABLE SIZE in
				1	2	3	4	5				
2 SPEED 1.25/1.25	LOW SPEED	LINE SPEED	fpm	74	81	88	96	103	30	2460	604	5/8
			mpm	22	25	27	29	31				
		LINE PULL	lb	15000	13500	12200	11200	10300				
			kg	6800	6120	5530	5080	4670				
	HIGH SPEED	LINE SPEED	fpm	146	160	175	189	204				
			mpm	44	49	53	57	62				
		LINE PULL	lb	7500	6700	6100	5600	5100				
			kg	3400	3030	2760	2540	2310				
SINGLE SPEED 2.50 in	LINE SPEED	fpm	146	160	175	189	204	60	2460	578	5/8	
		mpm	44	49	53	57	62					
	LINE PULL	lb	15000	13500	12200	11200	10300					
		kg	6800	6120	5530	5080	4670					
2 SPEED 1.50/1.50 in	LOW SPEED	LINE SPEED	fpm	80	88	96	104	112	40	1970	607	5/8
			mpm	24	28	29	32	34				
		LINE PULL	lb	15000	13500	12200	11200	10300				
			kg	5440	4890	4440	4080	3760				
	HIGH SPEED	LINE SPEED	fpm	155	170	186	201	217				
			mpm	51	56	61	66	71				
		LINE PULL	lb	6000	5400	4900	4500	4100				
			kg	2720	2440	2220	2040	1850				
CABLE CAPACITY			ft	55	125	195	275	360				
			m	18	38	60	84	110				

NOTE: The rated line pulls shown are for the hoist only. Consult the wire rope manufacturer for wire rope ratings.

HYDRAULIC SYSTEM REQUIREMENTS

Refer to the performance charts, above, to properly match your hydraulic system to hoist performance.

SINGLE SPEED GEAR MOTOR

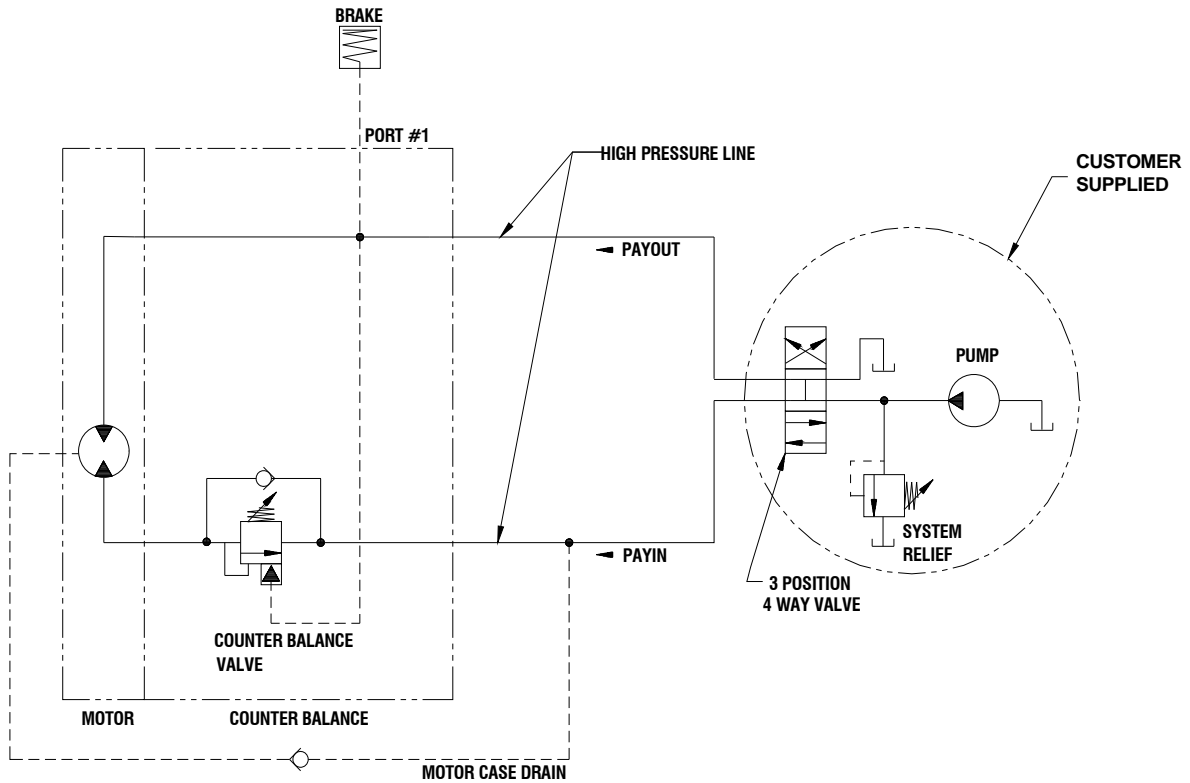

2 SPEED GEAR MOTOR

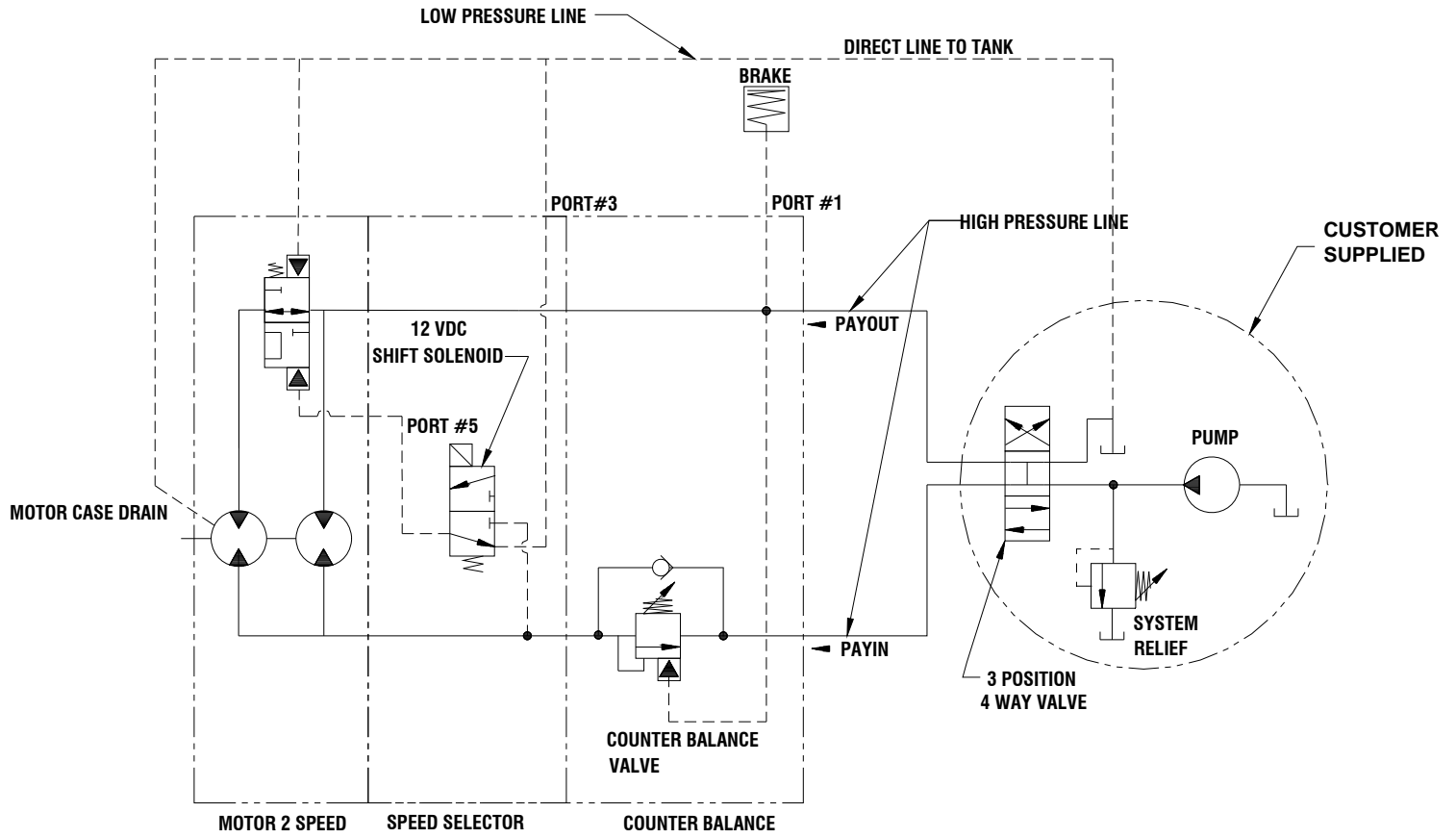

CABLE INSTALLATION

1. Unwind cable by rolling it out along the ground to prevent kinking. Securely wrap end of wire rope, opposite hook, with plastic or similar tape to prevent fraying.
2. Slide the wire rope through narrow end of the pocket against the drum flange. Wrap the wire rope around on the anchor (item #16) and pull the wire rope and anchor back into the wide end of the pocket. Use a soft hammer to drive the back side of the wire rope, firmly seating the wire rope and anchor into the pockets
3. Carefully run the hoist in the "reel-in" direction. Keeping tension on end of cable, spool all the cable onto the cable drum, taking care to form neatly wrapped layers.

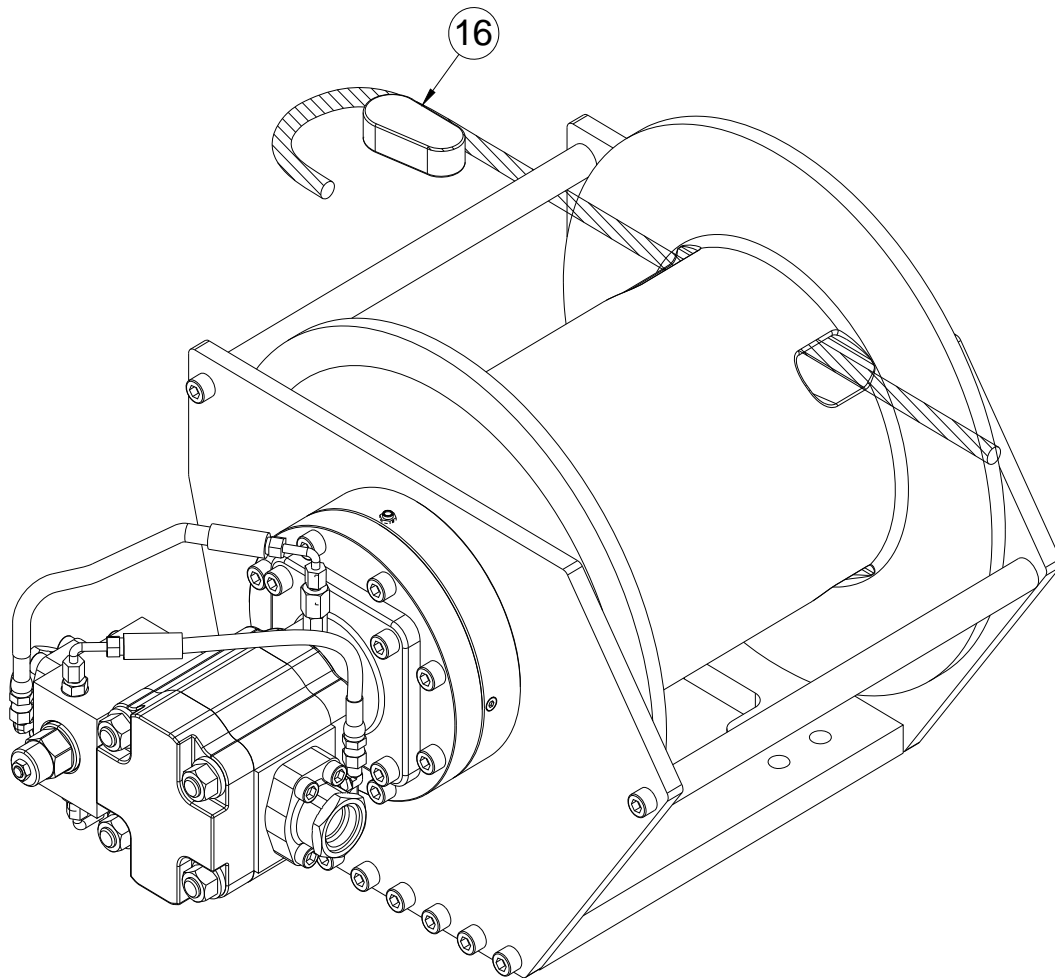

HOIST OPERATION

The best way to get acquainted with how your hoist operates is to make test runs before you use it. Plan your test in advance. Remember, you hear your hoist, as well as see it operate; learn to recognize the sounds of a light steady pull, a heavy pull, and sounds caused by load jerking or shifting. Gain confidence in operating your hoist and its use will become second nature with you.

The uneven spooling of cable while pulling a load is not a problem, unless there is a cable pileup on one end of drum. If this happens reverse the hoist to relieve the load and move your anchor point further to the center of the vehicle. After the job is done you can unspool and rewind for a neat lay of the cable.

MAINTENANCE

The owner is to ensure proper inspection intervals, in compliance with ANSI B30.5, 5-2.3, and will review hoist usage categories on a periodic basis. A Qualified Inspector should perform all maintenance and inspections.

- For hoist in occasional use less than 10 hours per month it is recommended a pre-use inspection and an annual 12 month inspection based on average use over a quarter.
- For hoist in moderate use, more than 10 but less than 50 hours per month, it is recommended a pre-use inspection, quarterly inspection, and an annual 12-month inspection based on average use over a quarter.
- For hoist in heavy use, more than 50 hours per month it is recommended a pre-use inspection, monthly inspection, quarterly inspection, and an annual 12 months inspection.

TROUBLE SHOOTING GUIDE

CONDITIONS	POSSIBLE CAUSE	CORRECTION
OIL LEAKS FROM HOIST	<ol style="list-style-type: none"> 1. Seals damaged or worn. 2. Too much oil. 3. Damaged o-rings. 4. Case drain not connected. 	<ol style="list-style-type: none"> 1. Replace seal 2. Drain excess oil. 3. Replace o-rings. 4. Connect case drain.
HOIST RUNS TOO SLOW	<ol style="list-style-type: none"> 1. Low flow rate. 2. Hydraulic motor worn out. 	<ol style="list-style-type: none"> 1. Check flow rate. Refer to Hydraulic Systems Performance Chart, page 3,4. 2. Replace motor.
BRAKE WILL NOT HOLD	<ol style="list-style-type: none"> 1. Incorrect directional control valve (cylinder spool, closed center). 2. Excessive hydraulic system back pressure. 3. Sprag clutch worn out. 	<ol style="list-style-type: none"> 1. Use only a motor spool (open center) directional control valve. 2. Reduce system back pressure to less than 100 psi. 3. Replace sprag clutch mechanism.
BRAKE WILL NOT RELEASE	<ol style="list-style-type: none"> 1. Brake line disconnected or blocked 	<ol style="list-style-type: none"> 1. Repair brake line.
HOIST WILL NOT OPERATE AT HIGH SPEED	<ol style="list-style-type: none"> 1. Shift solenoid not working. 	<ol style="list-style-type: none"> 1. Verify shift spool is energized.
HOIST OPERATES ERRATICALLY ON INHAUL	<ol style="list-style-type: none"> 1. Sprag hub is reversed. 	<ol style="list-style-type: none"> 1. Install sprag hub correctly.

INSTRUCTIONS FOR DISASSEMBLY

1. Remove wire rope from drum.
2. Rotating drum where both plugs #31 are visible thru side plate. Drain oil by removing both plugs and rotate drum until one plug is at the bottom of the hoist.
3. Remove plugs #30 and drain oil from brake.
4. When replacing lubricant, fill drum at plug #31 with 64oz of applicable lube for your climate from table on page 2 and fill brake at plug #30 with 16oz of applicable brake lube for your climate from table on page 2.

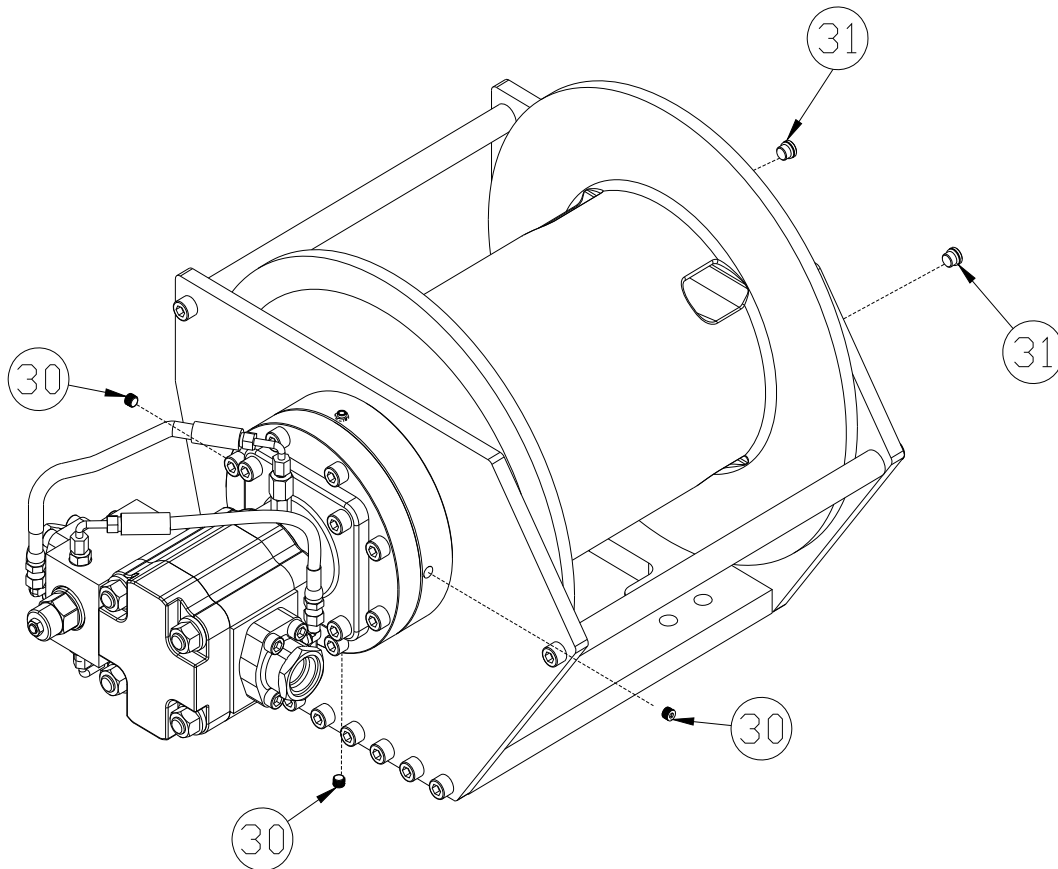

5. Disconnect brake release hose #39 from elbow fitting #22b and coupling #46a. Disconnect hose #43a from elbow fitting #22a and fitting tube to pipe #53. Remove hose #43b from elbow fitting #22c and coupling #46b. Remove flange mount #44a by removing (4) bolts #20 from motor. Remove flange mount #44b by removing (2) bolts #48 and (2) bolts #20.

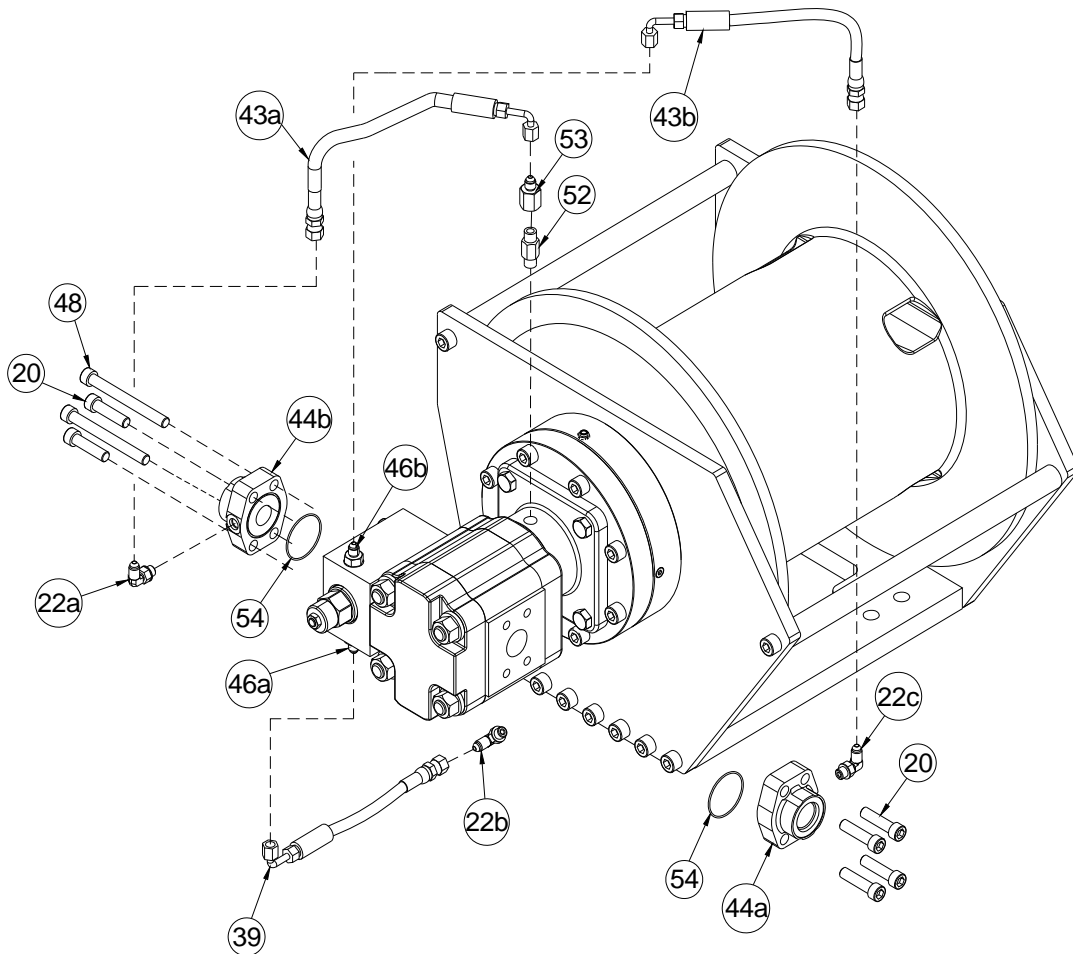

6. Remove (2) fittings #46a and #46b from counterbalance valve #41. Remove counterbalance valve #41 by removing (2) bolts #47. The motor #24 can be removed by removing (4) bolts #50.

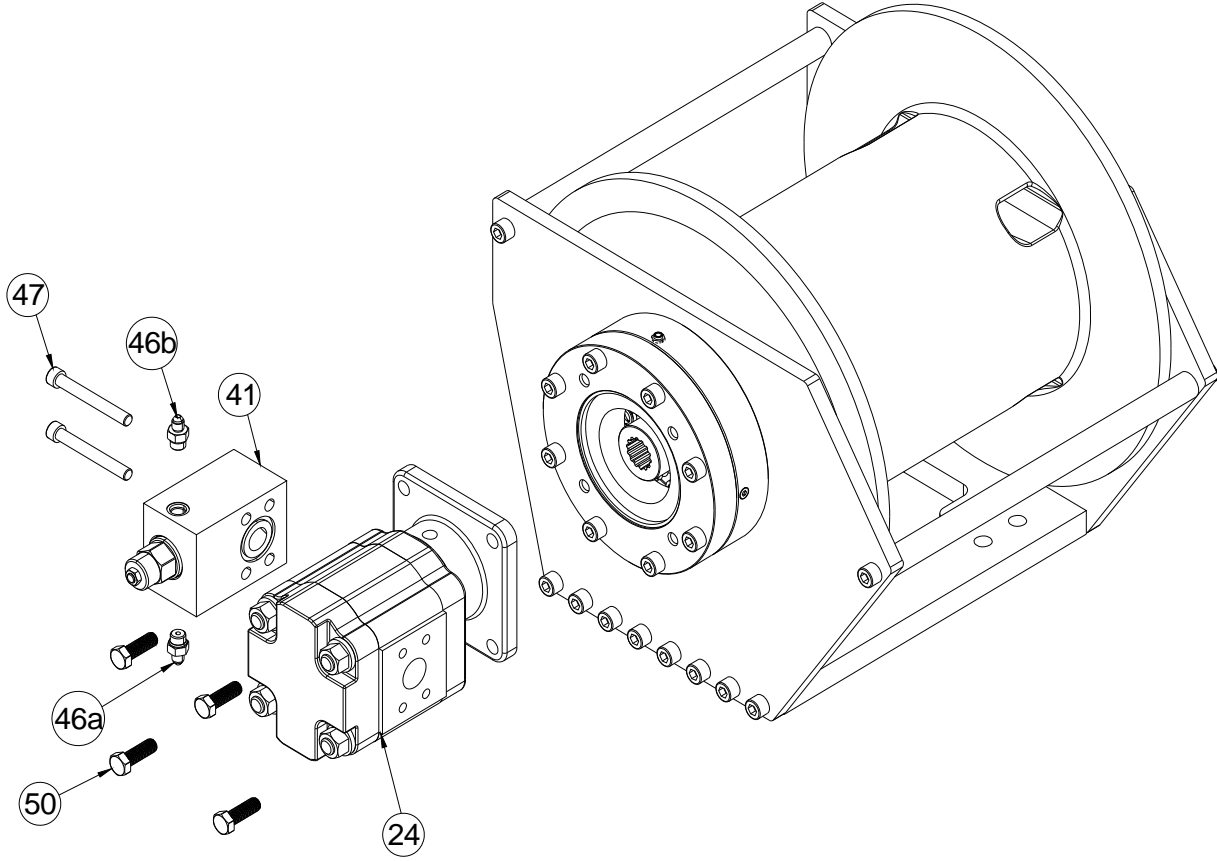

7. Remove brake cover #5 by removing (8) bolts #19. **The cover is spring loaded, use care when removing.** Remove o-ring #25 then springs #38 may be removed; residual oil may be present in the brake housing.
8. Remove piston #4 including o-rings and backup rings #26, #27, #28, and #29 by using a momentary puff of compressed air into the brake port located on top of the end bearing. Capture the piston by placing a shop rag over the opening prior to using air. Capture the piston by placing a shop rag over the opening prior to using air.
9. Remove the sprag brake hub assembly #3, (8) stator plates #6, and (7) disc brakes #7. The sprag brake hub assembly #3 is not a serviceable part, if damaged a replacement assembly should be ordered.

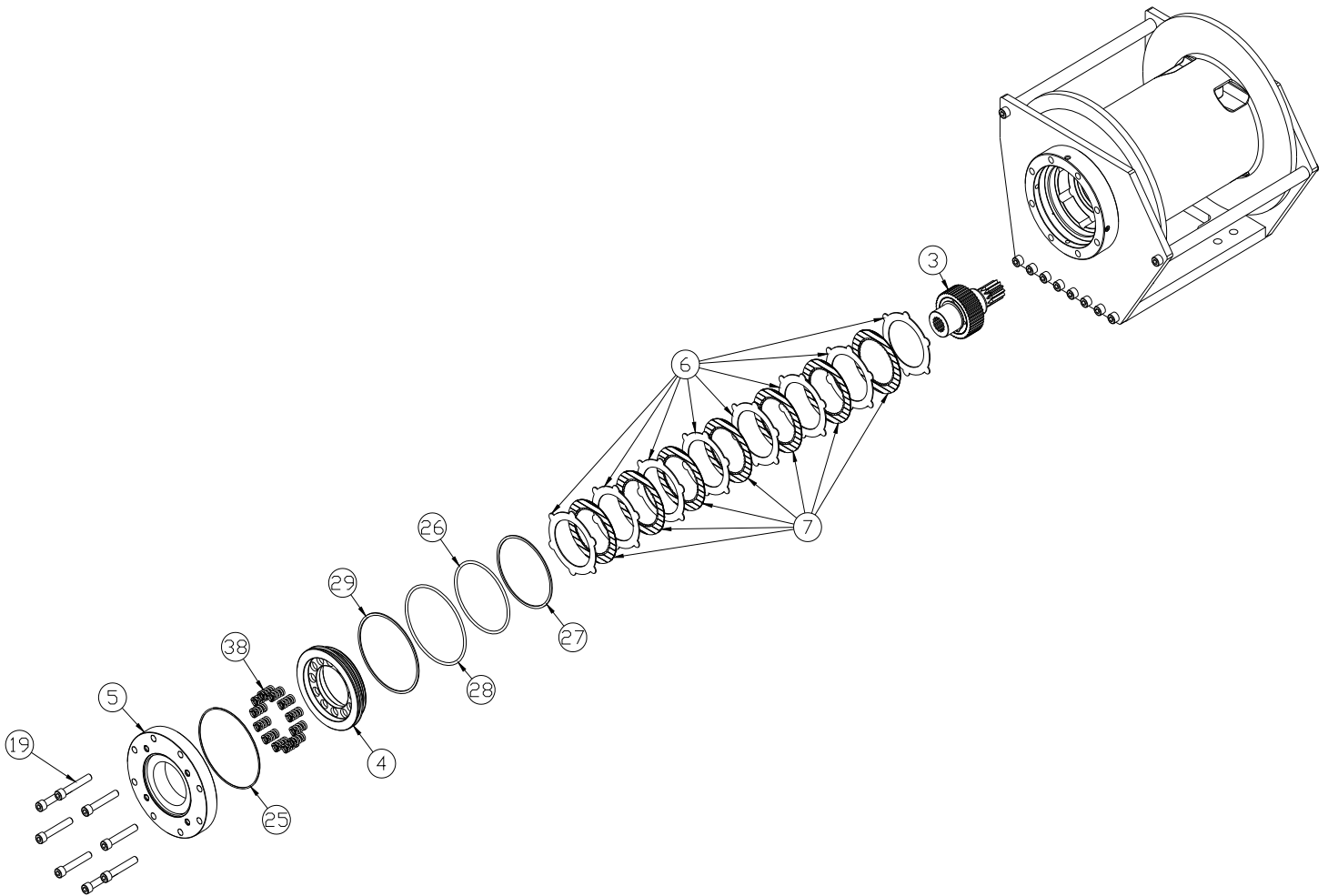

10. Remove brake housing #11 from side plate #13.
11. Remove the side plate by removing (10) bolts #21.

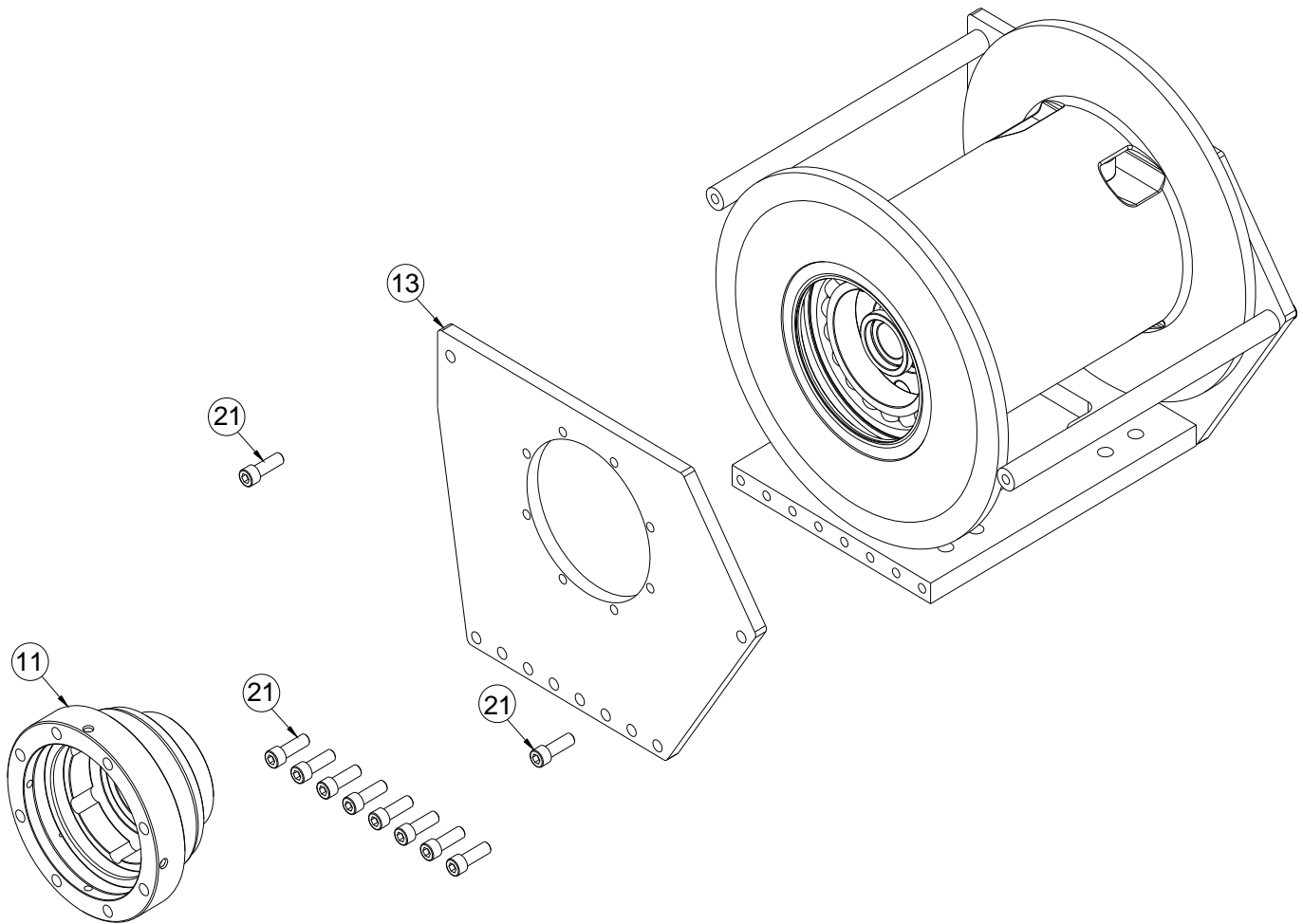

12. Remove base plate #15 and (2) tie bars #32 by removing (10) bolts #21
13. Remove side plate #14 by removing (7) bolts #21 and (1) bolt #40.
14. Seal #35 can now be removed.
15. Uninstall retaining ring #36 and then drum spacer #17 can be removed.

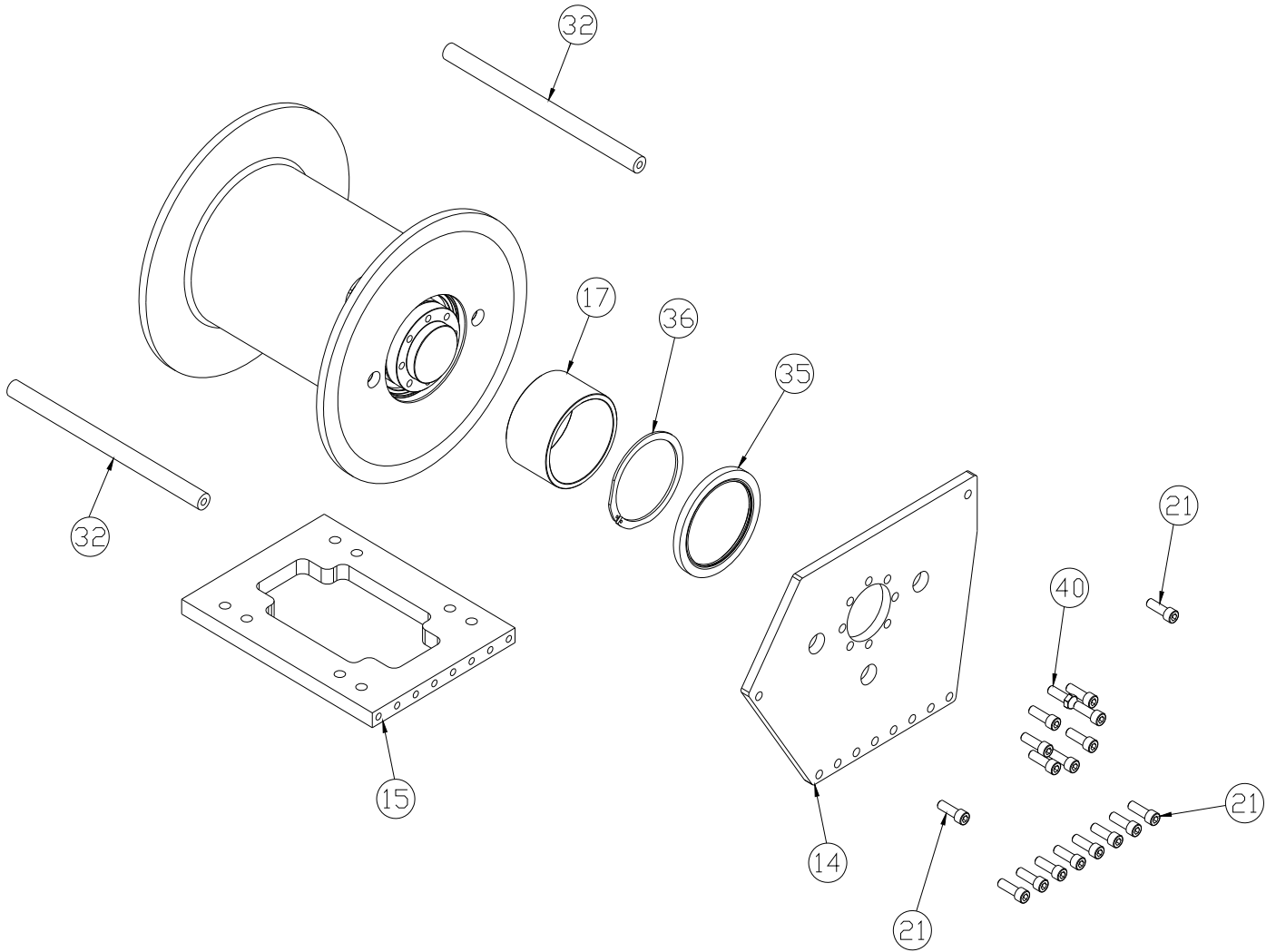

16. Remove seal #35

17. To remove bearing #12, spacer #42, input carrier assembly #2, and output sun #9, tap output carrier #1 with a soft hammer on the cable anchor side of drum #8

18. Uninstall retaining ring #37 then bearing #12 can be removed

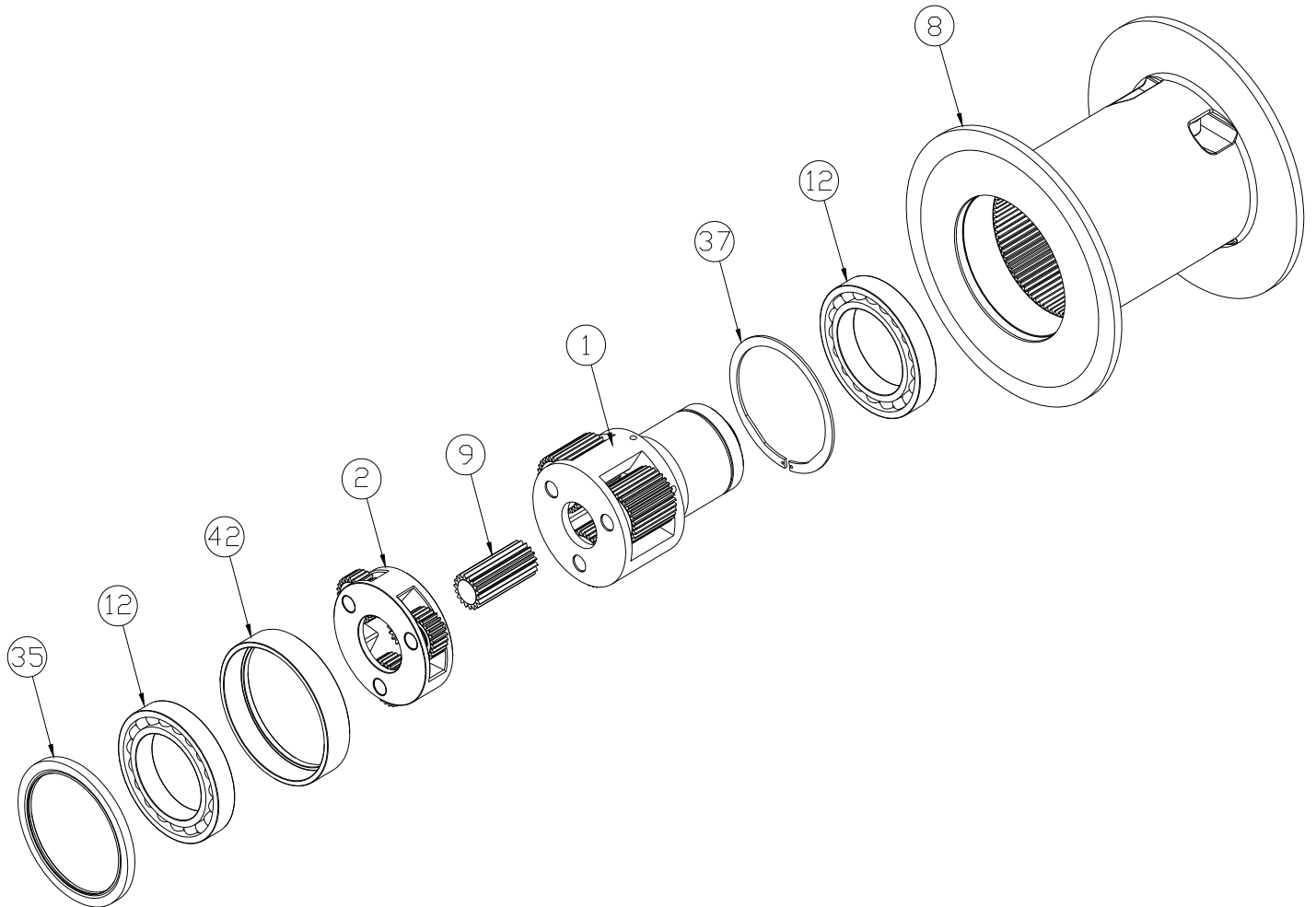

DISASSEMBLY OF INPUT CARRIER 41.62 RATIO

Carrier assemblies may be purchased as a complete assembly (see pg. 21) or parts may be purchased individually (see parts list below). If purchasing individual parts, it will be necessary to disassemble the input gear carrier as outlined below.

1. Carefully drive roll pin #71 into carrier pin #69 so that it is captured within carrier pin #69 but not touching the opposite side of the input carrier #66.
2. Tap carrier pin #69 to remove it from the input carrier #66.
3. Slide the planet gear #67 and the (2) thrust washers #70 from the carrier assembly #66. Bearing #68 may then be pressed out.
4. Remove the roll pin #71 from the carrier pin #69.

ITEM #	QTY	PART #	DESCRIPTION
66	1	317031	MACHINED-CARRIER-INPUT RCH
67	3	334215	GEAR-INPUT-PLANET-RCH
68	3	402138	BEARING-NEEDEL RCH
69	3	470119	PIN-INPUT RCH
70	6	518069	WASHER-THRUST RCH
71	3	470121	SPRING PIN-1/4 X 7/8 LG

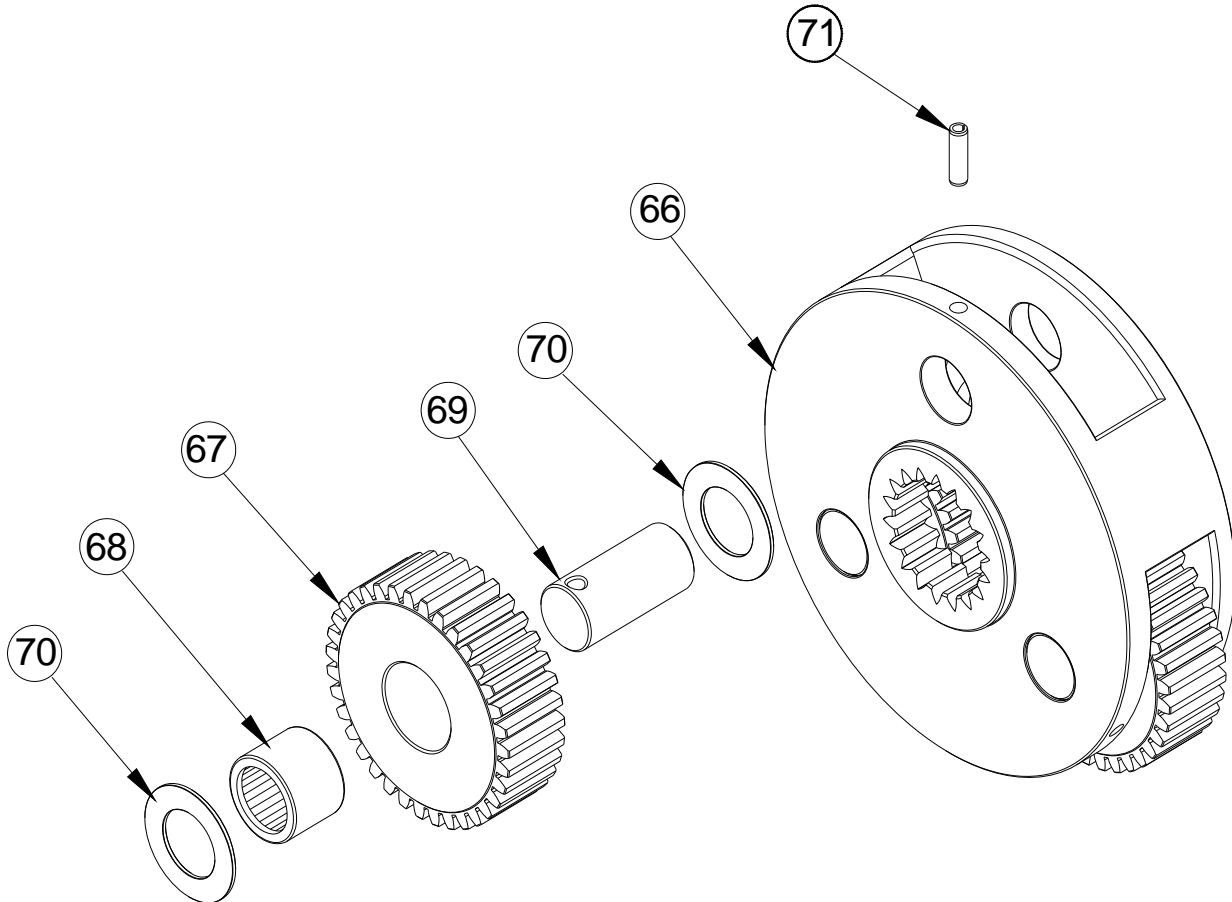

ASSEMBLY OF INPUT CARRIER 41.62 RATIO

Note: Item Numbers refer to Carrier parts list on page 16

1. Place carrier #66 on flat clean surface.
2. Place the gear #67 on a flat thin clean metal plate; Align the bearing with the chamfer facing toward the gear. Using a press, press the bearing flush to the gear surface.
3. Place thrust washer #70 on top of gear #67. Insert carrier pin #69 into carrier #66, aligning roll pin #71 with the matching hole on the carrier #66.
4. Insert a thrust washer between gear #67 and carrier #66. Completely insert carrier pin #69 into carrier #66 using care to align the roll pin hole in carrier pin #69 with the roll pin hole in the carrier #66.
5. Drive roll pin #71 into carrier #66 until roll pin #71 is $\frac{1}{4}$ " past flush with surface of the carrier #66.
6. Repeat this process to install the two remaining gears into the carrier.

DISASSEMBLY OF OUTPUT CARRIER

Carrier assemblies may be purchased as a complete assembly (see pg. 21) or parts may be purchased individually (see below). If purchasing individual parts, it will be necessary to disassemble the gear carrier as outlined below.

1. Carefully drive roll pin #76 into carrier pin #72 so that it is captured within carrier pin #75 but not touching the opposite side of the output carrier #72.
2. Tap carrier pin #75 to remove it from the output carrier #72.
3. Slide the gear #73 and thrust washers #74 from the carrier #72
4. Press bearings #77, from the gear #73
5. Remove the roll pin #76 from the carrier pin #75.
6. Repeat this process for the two remaining gears in the carrier.
7. Remove spacer #78 from the carrier #72

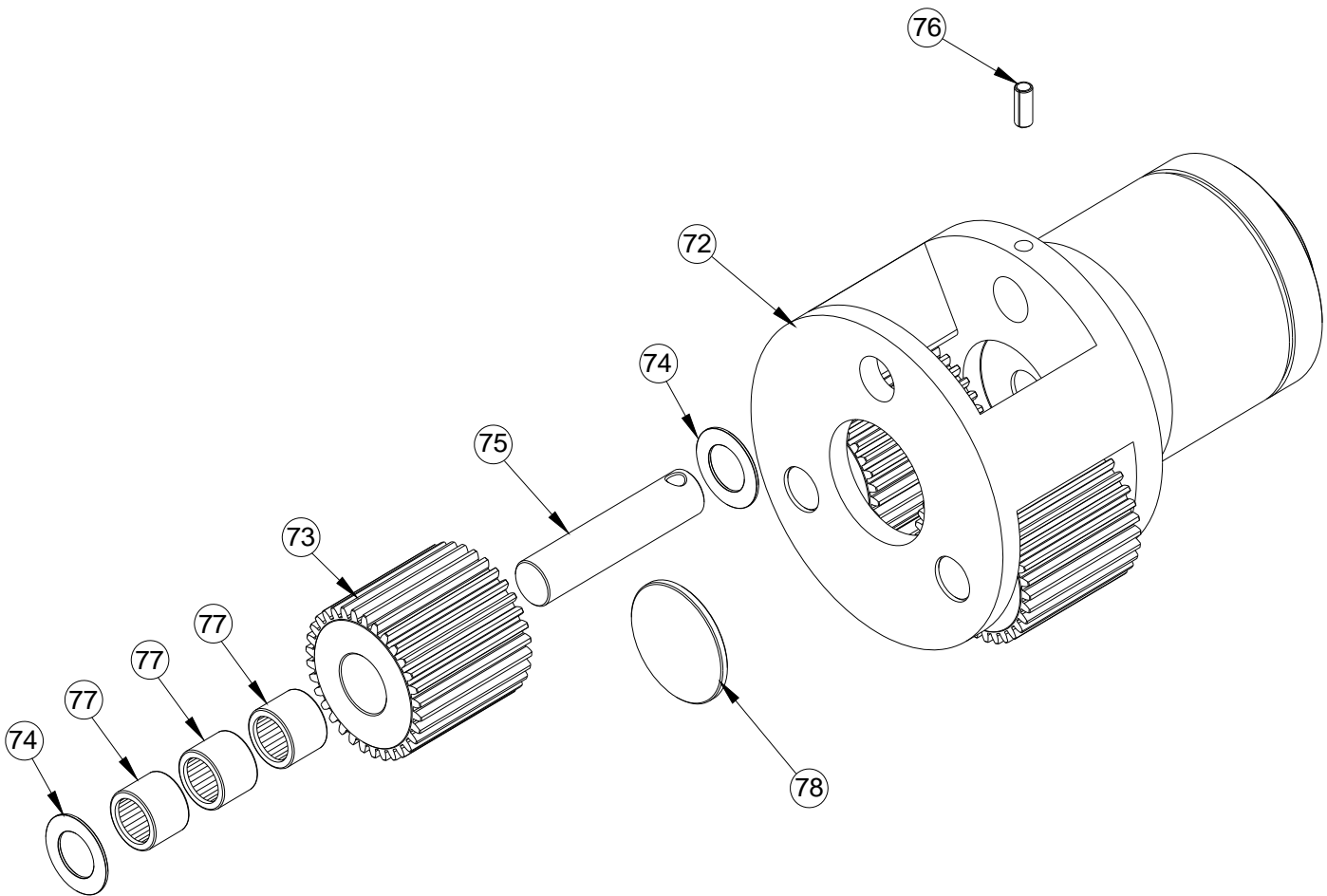

ITEM #	QTY	PART #	DESCRIPTION
72	1	317014	OUTPUT CARRIER
73	3	334210	PLANET GEAR
74	6	518069	THRUST WASHER
75	3	470118	CARRIER PIN
76	3	470120	ROLL PIN 3/8 DIA X 7/8 LG
77	9	402138	BEARING-NEEDLE ROLLER
78	1	408386	SPACER

ASSEMBLY OF OUTPUT CARRIER

Note: Item Numbers refer to Carrier parts list on page 18

1. Place output carrier #72 on flat clean surface.
2. Install spacer #78 into the carrier
3. Press in (3) Bearings #77 into gear #73. Repeat this process to install the bearings in the two remaining gears.
4. Slide the gear #73 into position in the output carrier #72.
5. Insert a thrust washer #74 between gear #75 and output carrier #72 (both sides of gear). Completely insert carrier pin #59 into carrier #56 using care to align the roll pin hole in carrier pin #75 with the roll pin hole in the output carrier #72.
6. Drive roll pin #76 into output carrier #72 until roll pin #76 is flush with surface of the output carrier #72.
7. Repeat this process to install the two remaining gears into the output carrier.

**RCH 15000 HOSE HOOKUP
41.62 RATIO SINGLE SPEED**

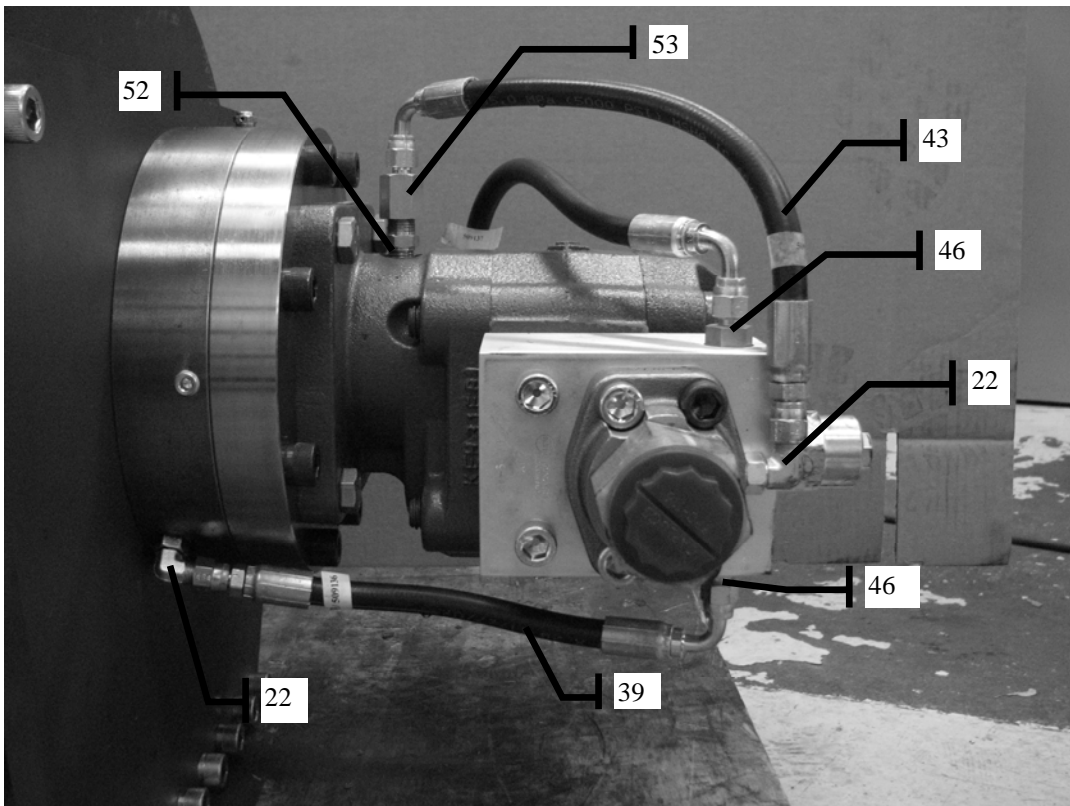
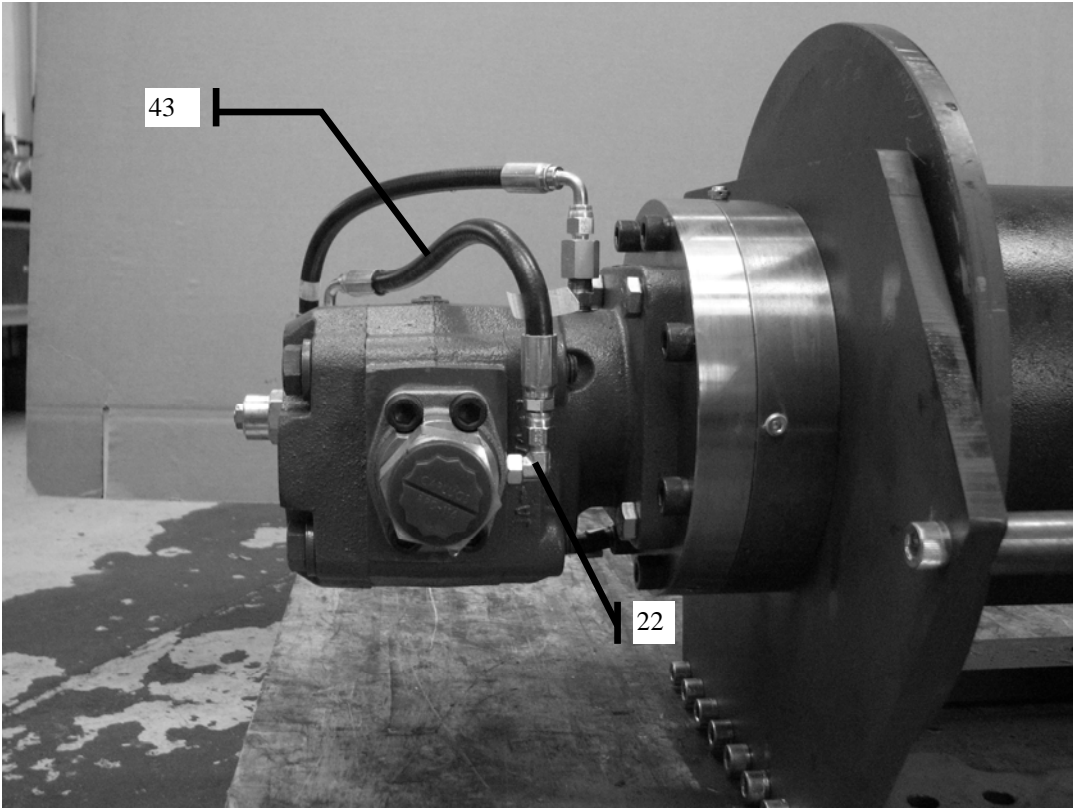

RCH 15000 PARTS DRAWING

41.62 RATIO SINGLE SPEED

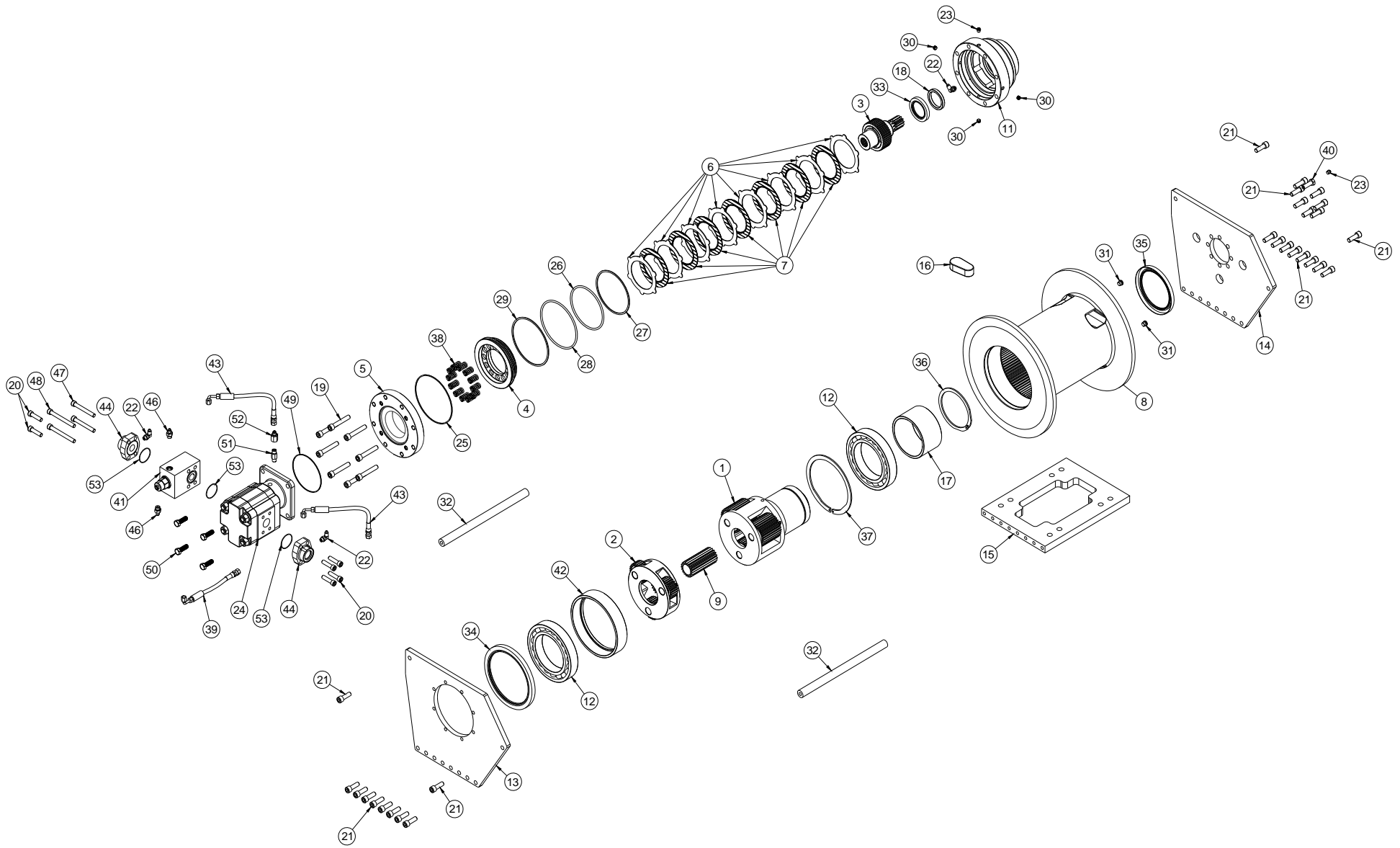

RCH 15000 PARTS LIST
41.62 RATIO SINGLE SPEED

ITEM	QTY	PART NO	DESCRIPTION
1	1	296698	ASSY-PLANETARY OUTPUT
2	1	296700	ASSY PLANETARY INPUT
3	1	296702	ASSY-BRAKE HUB SPRAG
4	1	306043	BRAKE PISTON
5	1	328171	BRAKE COVER RCH
6	8	330017	STATOR PLATE-BRAKE
7	7	330018	FRICTION PLATE-BRAKE
8	1	332258	CABLE DRUM
9	1	334211	GEAR-OUTPUT-SUN
10			NOT USED
11	1	338384	BRAKE-HOUSING
12	2	402137	BALL BEARING-DRUM
13	1	408389	SIDE PLATE-INPUT
14	1	408390	SIDE PLATE-OUTPUT
15	1	408385	PLATE-BASE
16	1	408387	WEDGE CABLE
17	1	412126	SPACER-DRUM
18	1	412128	BUSHING-BRAKE
19	8	414595	CAPSCREW-1/2-13 X 3.5 LG SOC HD
20	2	414431	CAPSCREW -7/16-14 X 1.75 LG. SOC HD.
21	27	414952	CAPSCREW-1/2-13NCX1 1/2LG,SOCHD,Z/P
22	2	432018	FITTING Parker#4-C5OX-S T-LOK, 7/16-20 90 degree
23	2	456008	RELIEF FIT-1/8-27PFT,BALL CHECK,Z/P
24	1	458158	MOTOR- 2.25 GEAR SECTION
25	1	462063	O-RING-AS-568-165
26	1	462082	O-RING 2-358
27	1	462083	BACKUP RING 8-357

ITEM	QTY	PART NO	DESCRIPTION
28	1	462084	O-RING 2-362
29	1	462085	BACKUP RING 8-362
30	3	468016	PIPE PLUG-1/8-27NPTF,HEX SOC. HD. Z/P
31	2	468043	PLUG,-5 SAE, 1/2"-20 UNF
32	2	474226	TIE BAR RCH
33	1	486089	SEAL-SHAFT OIL
34	1	486090	SEAL-SHAFT OIL
35	1	486091	SEAL-SHAFT OIL
36	1	490059	RING-RETAINING-DIN 471-130
37	1	490060	RING RETAINING DIN 472-200
38	12	494129	SPRING-BRAKE- 385LB IN/IN
39	1	509136	HOSE ASSY-HYD BRAKE RELEASE
40	1	514019	SPECIAL CAPSCREW-1/2-13 UNC X 1.50 LG HX HD GR8 Z/P
41	1	516046	VALVE-MOTOR CONTROL
42	1	518068	SPACER-BEARING-DRUM
43	2	509137	HOSE ASSEMBLY
44	2	432061	SAE 1.313-12 FLANGE MOUNT WITH -4 PORT
46	2	432051	COUPLING STRAIGHT THREAD 37DEG FLARE SAE ORB
47	2	414432	CAPSCREW -7/16-14 X 3.50 LG. SOC HD.
48	2	414434	CAPSCREW-7/16-14 X 4.25 LG SOC HD
49	1	462081	O-RING 2-159
50	4	414512	CAPSCREW-1/2-13 X 1.5 LG HX HD GR8 Z/P
51	1	432056	CHECK VALVE-INLINE
52	1	432055	FITTING-INDUSTRIAL TUBE TO PIPE
53	3	462099	O-RING 2-222

RCH 15000 PARTS DRAWING

41.62 RATIO 2 SPEED

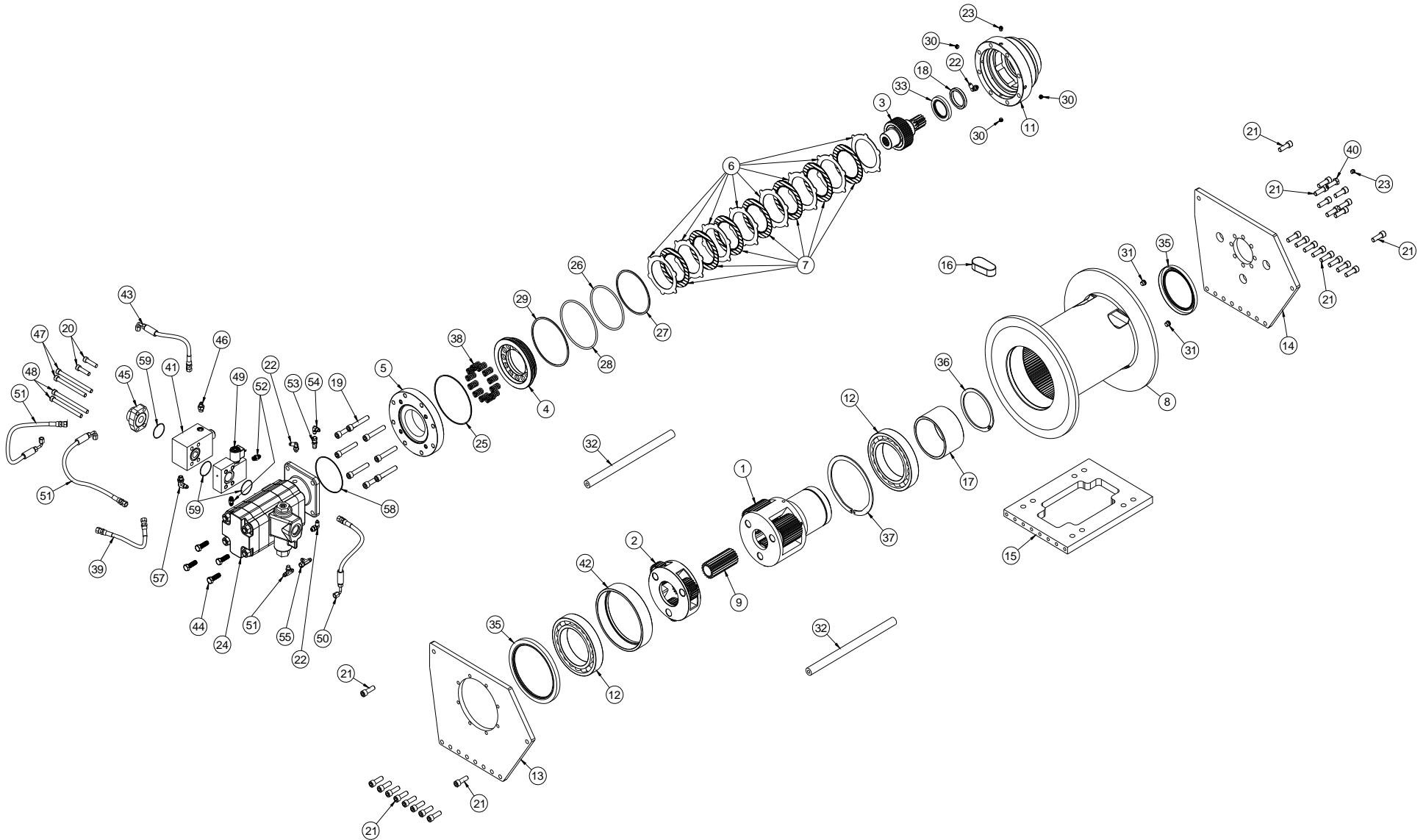

RCH 15000 PARTS LIST

41.62 RATIO 2 SPEED

ITEM	QTY	PART NO	DESCRIPTION	ITEM	QTY	PART NO	DESCRIPTION
1	1	296698	ASSY-PLANETARY OUTPUT	30	3	468016	PIPE PLUG-1/8-27NPTF,HEX SOC. HD. Z/P
2	1	296700	ASSY PLANETARY INPUT	31	2	468043	PLUG,-5 SAE, 1/2"-20 UNF
3	1	296702	ASSY-BRAKE HUB SPRAG	32	2	474226	TIE BAR RCH
4	1	306043	BRAKE PISTON	33	1	486089	SEAL-SHAFT OIL
5	1	328171	BRAKE COVER RCH	34	1	486090	SEAL-SHAFT OIL
6	8	330017	STATOR PLATE-BRAKE	35	1	486091	SEAL-SHAFT OIL
7	7	330018	FRICITION PLATE-BRAKE	36	1	490059	RING-RETAINING-DIN 471-130
8	1	332257	CABLE DRUM	37	1	490060	RING RETAINING DIN 472-200
9	1	334211	GEAR-OUTPUT-SUN	38	12	494129	SPRING-BRAKE- 385LB IN/IN
10			NOT USED	39	1	509138	HOSE ASSY-HYD BRAKE RELEASE
11	1	338384	BRAKE-HOUSING	40	1	514019	SPECIAL CAPSCREW-1/2-13 UNC X 1.50 LG HX HD GR8 Z/P
12	2	402137	BALL BEARING-DRUM	41	1	516046	VALVE-MOTOR CONTROL
13	1	408383	SIDE PLATE-INPUT	42	1	518068	SPACER-BEARING-DRUM
14	1	408384	SIDE PLATE-OUTPUT	43	1	509140	HOSE ASSEMBLY
15	1	408385	PLATE-BASE	44	4	414512	CAPSCREW-1/2-13 X 1.5 LG HX HD GR8 Z/P
16	1	408387	WEDGE CABLE	45	1	432060	SAE 1.313-12 FLANGE MOUNT
17	1	412126	SPACER-DRUM	46	1	432051	COUPLING STRAIGHT THREAD 37DEG FLARE SAE ORB
18	1	412128	BUSHING-BRAKE	47	2	414435	CAPSCREW -7/16-14 X 5.00 LG SOC HD
19	8	414438	CAPSCREW-1/2-13X 3.5 LG SOC HD	48	2	414436	CAPSCREW 7/16-14-5.75 LG SOC HD.
20	2	414431	CAPSCREW -7/16-14 X 1.75 LG. SOC HD.	49	1	516057	2 SPD SHIFT BLOCK
21	27	414952	CAPSCREW-1/2-13NCX1 1/2LG,SOCHD,Z/P	50	1	509139	HOSE ASSEMBLY
22	2	432018	FITTING Parker#4-C5OX-S T-LOK, 7/16-20 90 degree	51	2	509141	HOSE ASSEMBLY
23	2	456008	RELIEF FIT-1/8-27PFT,BALL CHECK,Z/P	52	2	432023	FITTING-7/16-20,PARKER#0503-4-4/EQ
24	1	458154	MOTOR-1.00 & 1.25 GEAR SECTIONS	53	1	432046	SWIVEL CONNECTOR 37 DEG SWIVEL / NPTF
		458156	MOTOR-1.00 & 1.00 GEAR SECTIONS	54	1	432047	UNION ELBOW 37 DEG FLARE / 37 DEG. FLARE
25	1	462063	O-RING-AS-568-165	55	1	432048	TEE SWIVEL NUT RUN 37 DEG FLARE
26	1	462082	O-RING 2-358	56	1	432049	TEE STRAIGHT THREAD BRANCH 37DEG FLARE SAE ORB
27	1	462083	BACKUP RING 8-357	57	1	432052	MALE 90 DEG. ELBOW -37 DEG FLARE / SAE-ORB
28	1	462084	O-RING 2-362	58	1	462081	O-RING 2-159
29	1	462085	BACKUP RING 8-362	59	3	462099	O-RING 2-222

RCH 15000 20 INCH FLANGE PARTS DRAWING
41.62 RATIO 2 SPEED

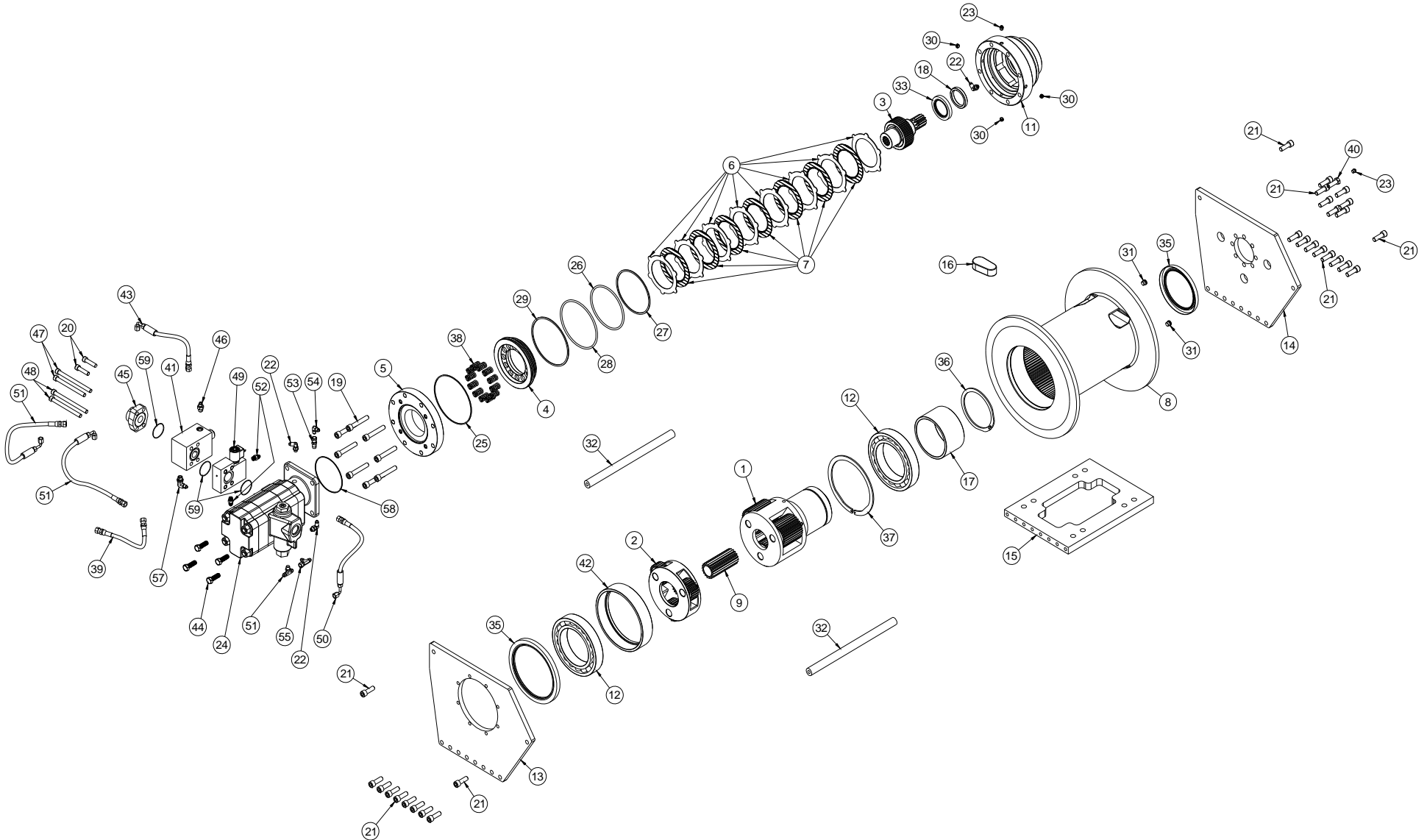

RCH 15000 20 INCH FLANGE PARTS LIST

41.62 RATIO 2 SPEED

ITEM	QTY	PART NO	DESCRIPTION	ITEM	QTY	PART NO	DESCRIPTION
1	1	296698	ASSY-PLANETARY OUTPUT	31	2	468043	PLUG,-5 SAE, 1/2"-20 UNF
2	1	296700	ASSY PLANETARY INPUT	32	2	474226	TIE BAR RCH
3	1	296702	ASSY-BRAKE HUB SPRAG	33	1	486089	SEAL-SHAFT OIL
4	1	306043	BRAKE PISTON	34	1	486090	SEAL-SHAFT OIL
5	1	328171	BRAKE COVER RCH	35	1	486091	SEAL-SHAFT OIL
6	8	330017	STATOR PLATE-BRAKE	36	1	490059	RING-RETAINING-DIN 471-130
7	7	330018	FRICTION PLATE-BRAKE	37	1	490060	RING RETAINING DIN 472-200
8	1	332259	CABLE DRUM	38	12	494129	SPRING-BRAKE- 385LB IN/IN
9	1	334211	GEAR-OUTPUT-SUN	39	1	509138	HOSE ASSY-HYD BRAKE RELEASE
10			NOT USED	40	1	514019	SPECIAL CAPSCREW-1/2-13 UNC X 1.50 LG HX HD GR8 Z/P
11	1	338384	BRAKE-HOUSING	41	1	516046	VALVE-MOTOR CONTROL
12	2	402137	BALL BEARING-DRUM	42	1	518068	SPACER-BEARING-DRUM
13	1	408391	SIDE PLATE-INPUT	43	1	509140	HOSE ASSEMBLY
14	1	408392	SIDE PLATE-OUTPUT	44	4	414512	CAPSCREW-1/2-13 X 1.5 LG HX HD GR8 Z/P
15	1	408385	PLATE-BASE	45	1	432060	SAE 1.313-12 FLANGE MOUNT
16	1	408387	WEDGE CABLE	46	1	432051	COUPLING STRAIGHT THREAD 37DEG FLARE SAE ORB
17	1	412126	SPACER-DRUM	47	2	414435	CAPSCREW -7/16-14 X 5.00 LG SOC HD
18	1	412128	BUSHING-BRAKE	48	2	414436	CAPSCREW 7/16-14-5.75 LG SOC HD.
19	8	414438	CAPSCREW-1/2-13X 3.5 LG SOC HD	49	1	516057	2 SPD SHIFT BLOCK
20	2	414431	CAPSCREW -7/16-14 X 1.75 LG. SOC HD.	50	1	509139	HOSE ASSEMBLY
21	27	414952	CAPSCREW-1/2-13NCX1 1/2LG,SOC HD,Z/P	51	2	509141	HOSE ASSEMBLY
22	2	432018	FITTING Parker#4-C5OX-S T-LOK, 7/16-20 90 degree	52	2	432023	FITTING-7/16-20,PARKER#0503-4-4/EQ
23	2	456008	RELIEF FIT-1/8-27PFT,BALL CHECK,Z/P	53	1	432046	SWIVEL CONNECTOR 37 DEG SWIVEL / NPTF
24	1	458158	MOTOR-1.25 & 1.25 GEAR SECTIONS	54	1	432047	UNION ELBOW 37 DEG FLARE / 37 DEG. FLARE
25	1	462063	O-RING-AS-568-165	55	1	432048	TEE SWIVEL NUT RUN 37 DEG FLARE
26	1	462082	O-RING 2-358	56	1	432049	TEE STRAIGHT THREAD BRANCH 37DEG FLARE SAE ORB
27	1	462083	BACKUP RING 8-357	57	1	432052	MALE 90 DEG. ELBOW -37 DEG FLARE / SAE-ORB
28	1	462084	O-RING 2-362	58	1	462081	O-RING 2-159
29	1	462085	BACKUP RING 8-362	59	3	462099	O-RING 2-222
30	3	468016	PIPE PLUG-1/8-27NPTF,HEX SOC. HD. Z/P				

15K 41.62 RATIO 2.5 IN SINGLE SPEED DIMENSIONAL DRAWING

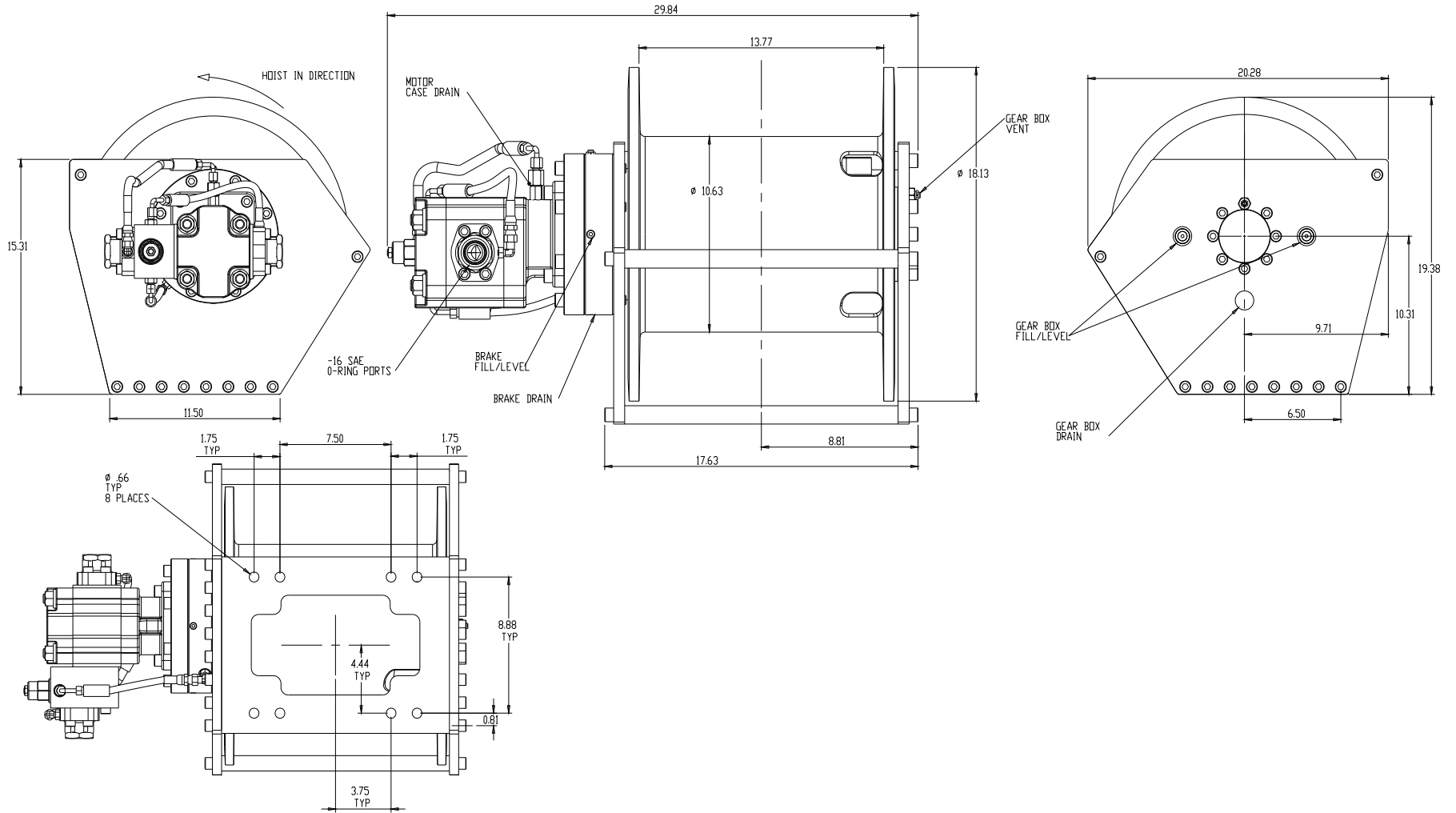

15K 41.62 RATIO 1.25&1.25 AND 1.50&1.50 IN 2 SPEED DIMENSIONAL DRAWING

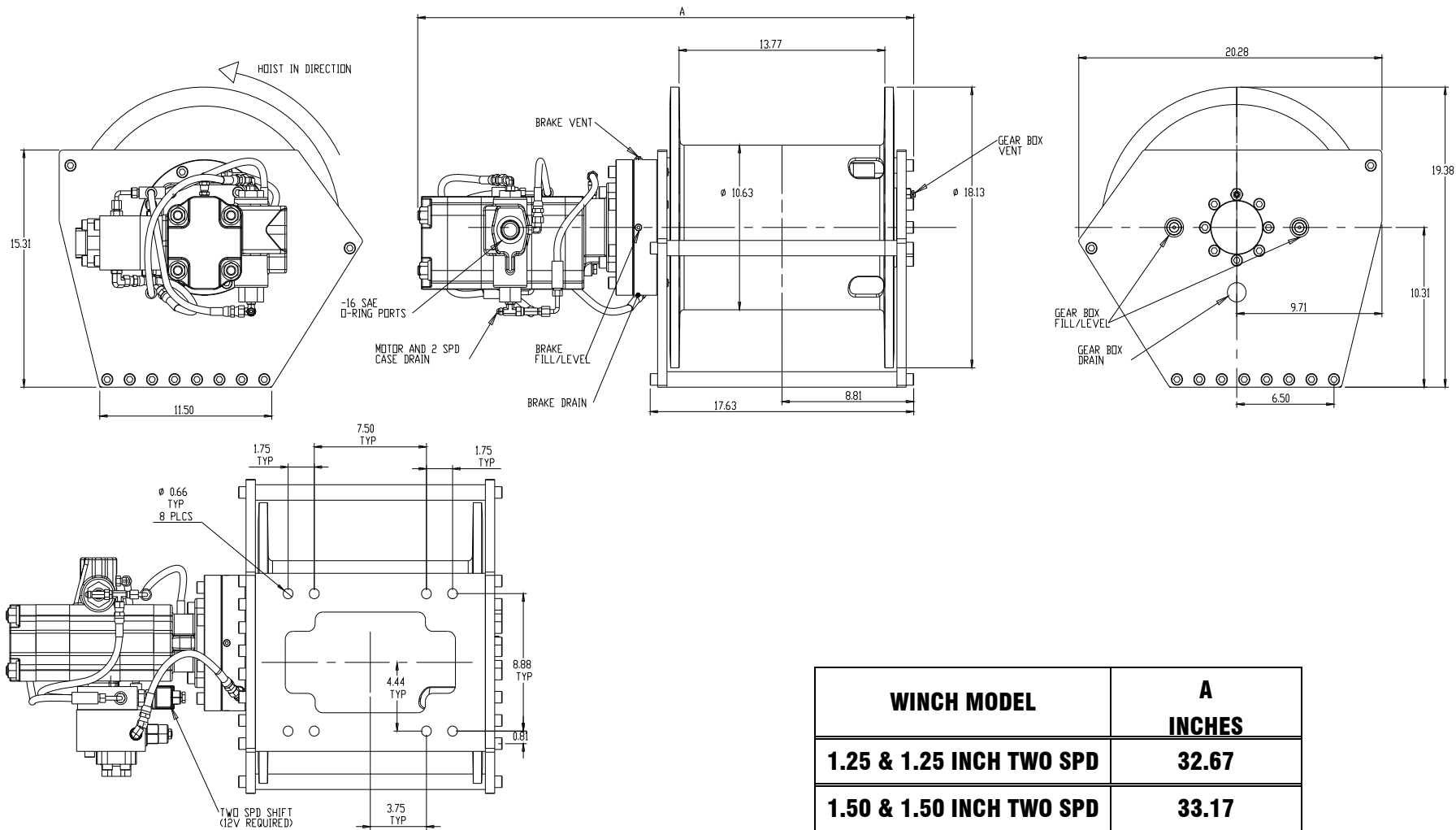

15K 41.62 RATIO 20 INCH FLANGE 1.25&1.25 IN 2 SPEED DIMENSIONAL DRAWING

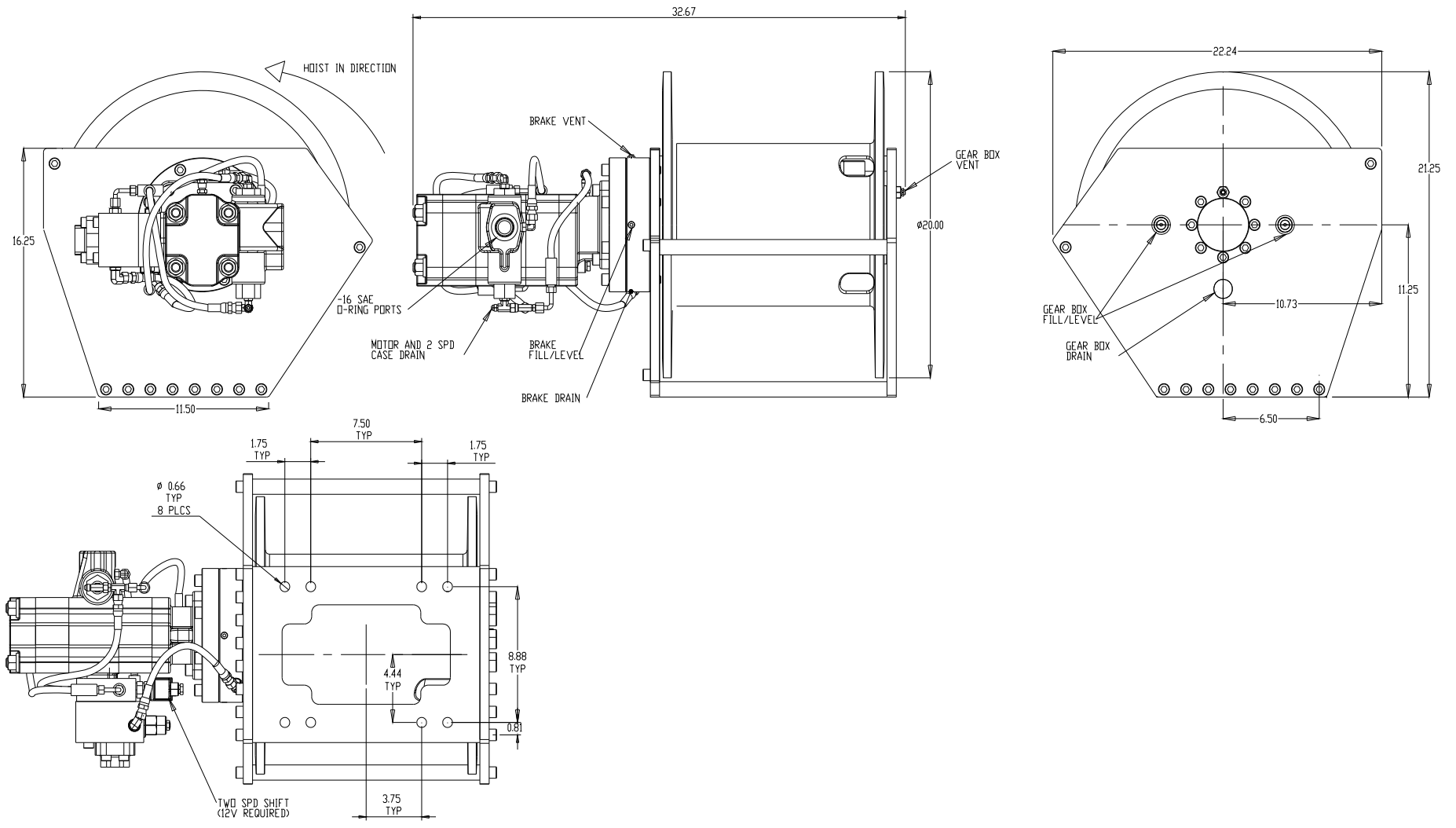

NOTES:

LIMITED WARRANTY

RAMSEY WINCH warrants each new RAMSEY WINCH to be free from defects in material and workmanship for a period of one (1) year from date of purchase.

The obligation under this warranty, statutory or otherwise, is limited to the replacement or repair at the Manufacturer's factory, or at a point designated by the Manufacturer, of such part that shall appear to the Manufacturer, upon inspection of such part, to have been defective in material or workmanship.

This warranty does not obligate RAMSEY WINCH to bear the cost of labor or transportation charges in connection with the replacement or repair of defective parts, nor shall it apply to a product upon which repair or alterations have been made, unless authorized by Manufacturer, or for equipment misused, neglected or which has not been installed correctly.

RAMSEY WINCH shall in no event be liable for special or consequential damages. RAMSEY WINCH makes no warranty in respect to accessories such as being subject to the warranties of their respective manufacturers.

RAMSEY WINCH, whose policy is one of continuous improvement, reserves the right to improve its products through changes in design or materials as it may deem desirable without being obligated to incorporate such changes in products of prior manufacture.

If field service at the request of the Buyer is rendered and the fault is found not to be with RAMSEY WINCH's product, the Buyer shall pay the time and expense to the field representative. Bills for service, labor or other expenses that have been incurred by the Buyer without approval or authorization by RAMSEY WINCH will not be accepted.

See warranty card for details.



RAMSEY WINCH COMPANY

Post Office Box 581510

Tulsa, Oklahoma 74158-1510

Telephone: (#918) 438-2760 FAX: (#918) 438-6688

OM-914230-0509-A