

Worm Gear Speed Reducers



ramsey.com



CHOICE OF PROFESSIONALS



Table of Contents

Table of contents and limited warranty excerpt	2
Features and Performance data tables	3
Model S-7, Model S-200, Model S-400 Mid Mount Speed Reducers	4
Model S-600, Model S-700, Model S-800, Model S-930 Mid Mount Speed Reducers.....	5

How to Select and Order Your Speed Reducer

- 1. Torque** Check the performance data tables and choose the model or models having rated output torque equal or greater than the torque required for the job.
- 2. Speed**—Note the maximum input RPM. Do not exceed this RPM.

To order, specify model number, dimensions and specifications of output shaft (if not standard); state whether output shaft is to rotate in same direction or opposite direction of input shaft rotation; whether output shaft should be extended to right or left (when facing input) and whether automatic worm brake is desired as an extra.

Note: Specifications and Performance data are based on **NO** overhond load.

WARNING

Winches and Speed Reducers are not to be used to lift, support or otherwise transport personnel. For Speed Reducers with a cable drum, a minimum of five (5) wraps of cable around the drum is necessary to support the rated load. A cable clamp is not designed to hold the load.

Limited Warranty Excerpt

Ramsey Winch warrants each new winch and speed reducer to be free from defects in workmanship for a period of one (1) year from date of purchase. The obligation under this warranty, statutory or otherwise, is limited to the replacement or repair at our factory of such part or parts as shall appear to us upon inspection to be defective in materials and workmanship. Complete warranty statement packed with each item.



Ramsey Worm Gear Mid Mount Speed Reducers

Ramsey speed reducers are in use around the world in conveyor systems, pipeline machines, railroad car spotters, and thousands of other applications. All models feature smooth, quiet operation, and completely enclosed gearing. All models are manufactured for intermittent duty.

Mid Mount Speed Reducers available with mounting face above the input shaft . Gear ratios range from 29:1 up to 60:1; output torque from 4,800 to 99,300 inch-pounds.

Features

- Side-opening housing
- Optional shaft bearing stands
- Oil-cooled automatic worm brake (optional extra)

Specifications and Performance Data

Model	Rated Output Torque In./Lbs.	Rated Input Torque In./Lbs.	Max Input RPM	Gear Reduction
S7	4,800	400	1,200	38:1
S200	15,500	800	1,000	60:1
S246	15,500	1,000	1,000	46:1
SD200	15,500	1,050	1,000	30:1
S400	26,600	2,650	900	29:1
S600	36,000	2,600	900	40:1
S700	53,000	4,350	700	35:1
S800	78,700	5,650	500	40:1
S930	99,300	7,100	400	40:1

*Data is based on no overhung load. Outboard end of shaft must be supported.

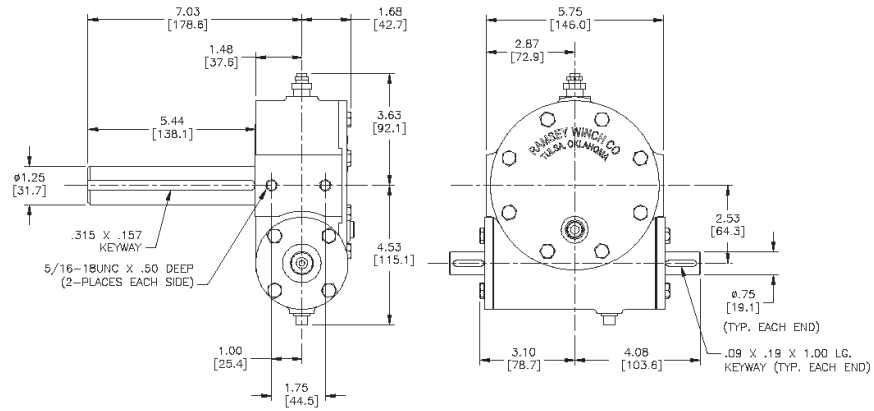

Model S-7

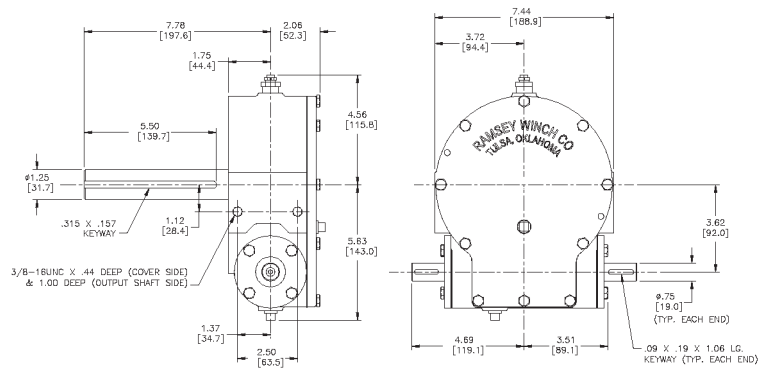

Model S-200

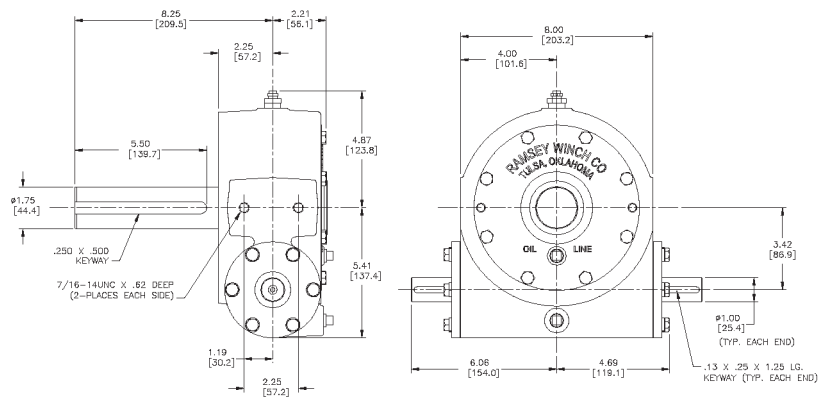

Model S-400

DIMENSIONS SHOWN ARE INCHES OVER MILLIMETERS

Model S-600

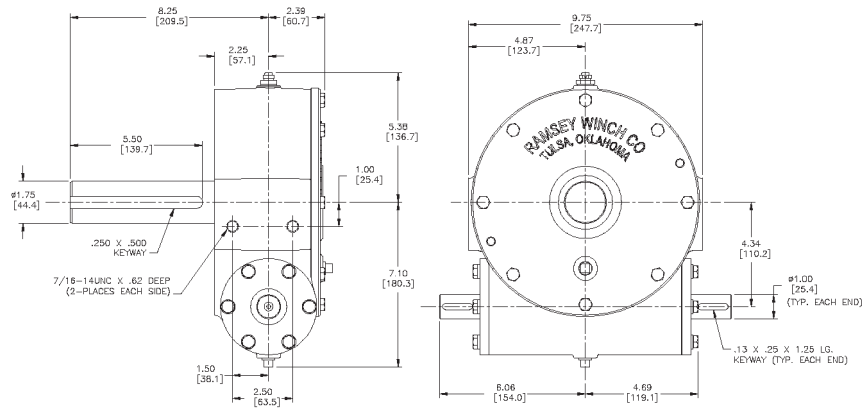

Model S-700

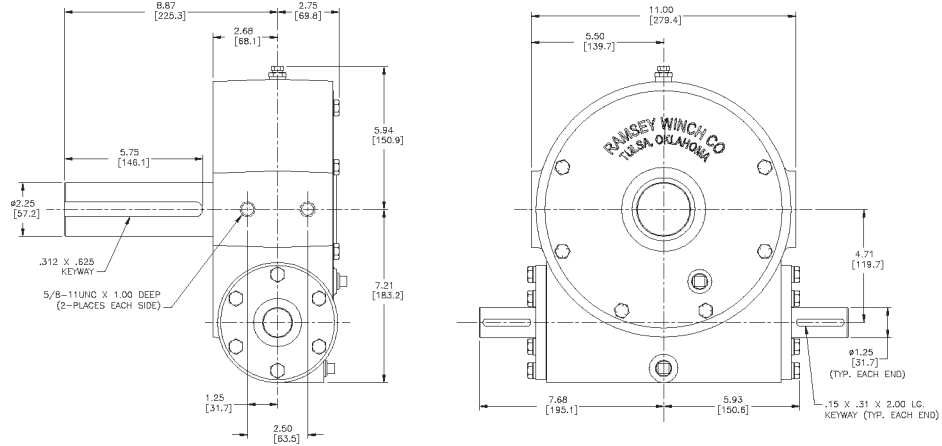

Model S-800

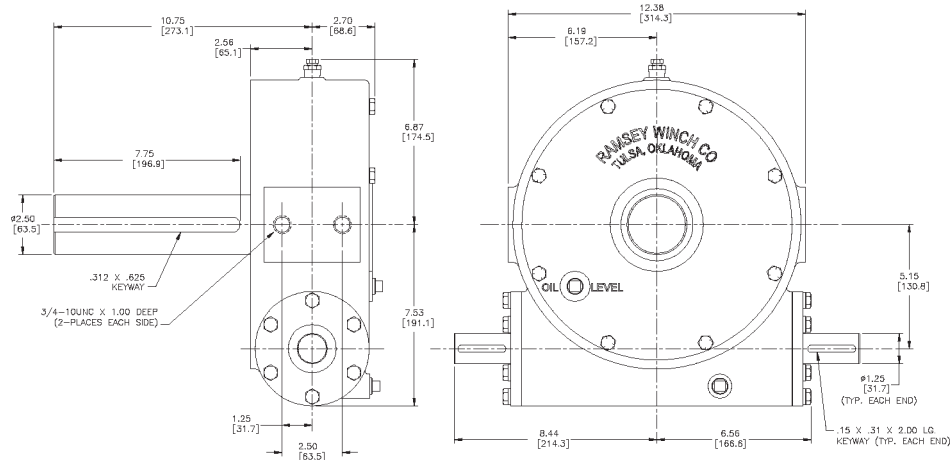

Model S-930

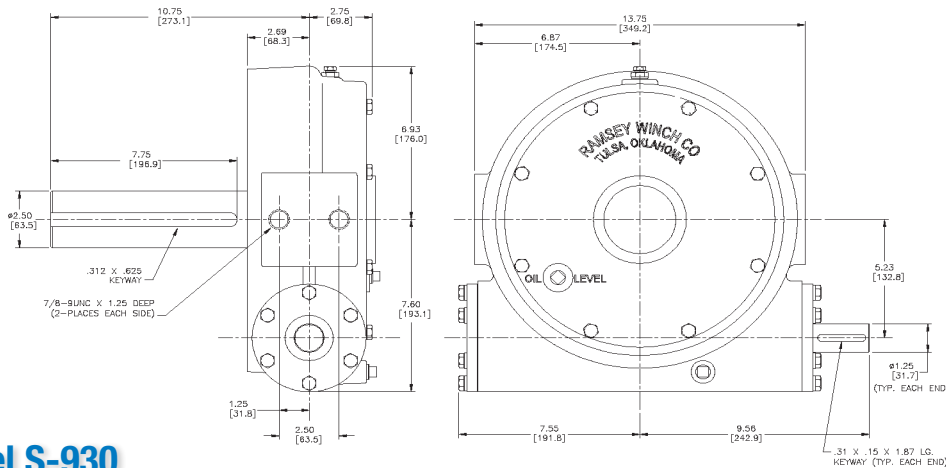

DIMENSIONS SHOWN
ARE INCHES OVER
MILLIMETERS



P.O. Box 581510 • Tulsa, OK 74158-1510 U.S.A • Phone: (918) 438-2760 • Fax: (918) 438-6688

For more information visit:

ramsey.com

