

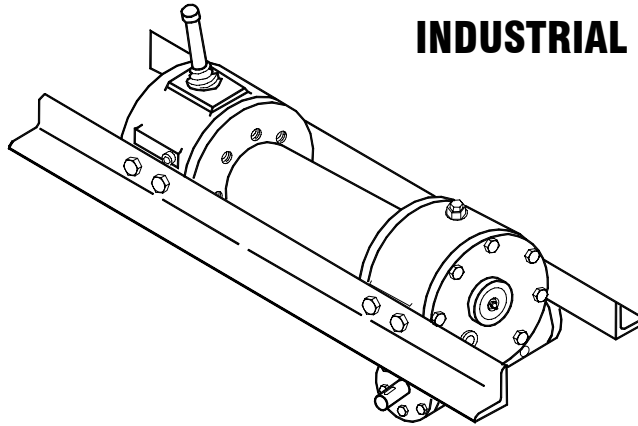

Ramsey Winch Company
OWNER'S MANUAL
MODEL 800 / H-800 SERIES
DOW-LOK® EQUIPPED
INDUSTRIAL LOW-MOUNT WINCHES



Rated Line Pull (lbs.)		20,000					
(kg)		9,060					
Gear Reduction		40:1					
Shipping Weight:	800	Y-800	H-800	HY-800			
	315 lbs. (143 Kg)	290 lbs (132 Kg)	330 lbs. (150 Kg)	325 lbs. (148 Kg)			
Layer of Cable		1	2	3	4	5**	
*Rated line pull per layer	(lbs.)	20,000	16,600	14,200	12,400	11,000	
	(kg)	9,060	7,510	6,430	5,610	4,980	
Cable Capacity	(ft)	35	75	125	180	240	
	(m)*	10	22	38	54	72	
Cable Capacity	(ft)	20	45	75	110	150	
	(m)*	6	13	22	33	45	
*Line speed							Worm RPM
800	FPM	22	27	32	35	40	570
	MPM	6.6	8.1	9.7	10.9	12.3	
H-800	FPM	18	22	26	29	33	460
	MPM	5.4	6.6	7.9	8.8	10.0	30 GPM
* These specifications are based on recommended wire rope of .63 inch (16mm) diameter 6x19 extra improved plow steel cable							
** Fifth layer does not conform to SAE J706							

Note: The rated line pulls shown are for the winch only. Consult wire rope manufacturer for wire rope ratings

Congratulations

Ramsey Winches are designed and built to exacting specifications. Great care and skill go into every winch we make. If the need should arise, warranty procedure is outlined on the back of your self-addressed postage paid warranty card. Please read and fill out the enclosed warranty card and send it to Ramsey Winch Company. If you have any problems with your winch, please follow instructions for prompt service on all warranty claims. Refer to back page for limited warranty.



CAUTION: READ AND UNDERSTAND THIS MANUAL BEFORE INSTALLATION AND OPERATION OF WINCH. SEE WARNINGS!

Contents

Performance Specifications	COVER	Trouble Shooting Guide	9
Safety Precautions.....	1	Instructions for Overhaul	10-16
Techniques of Operation	2-3	Disassembly	10-13
Winch Maintenance	3	Re-assembly	13-16
Winch Mounting	4	Dimensional Drawings	
Cable Installation	4	Model 800 / Y-800.....	17
Adjusting the Oil Cooled		Model H-800 / HY-800.....	18
Worm Brake	4	H-800 / HY-800 Short Coupling.....	19
Servicing the Oil Cooled		H-800 / HY-800 Air Shifter	20
Worm Brake	5	HY-800 Short Coupling/Low Profile Shifter	21
Re-assembling and		Parts List and Parts Drawing	
Checking the Brake.....	5	Model 800 / Y-800.....	22-23
Test for Proper Brake Assembly	6	Model H-800 / HY-800.....	24-25
Instructions for Checking Assembly Arrangement		H-800 / HY-800 SC.....	26-27
and Setting of Worm Brake	6	H-800 / HY-800 Air Shifter	38-29
Adjustment of Clutch Air Shifter	7	Hy-800 Short Coupling/Low Profile Shifter.....	30-31
Hydraulic System Requirements	8	Warranty	BACK COVER



Safety Precautions To Guard Against Possible Injury

- A. Clutch must be totally engaged before starting the winch operation.**
- B. Do not disengage clutch under load.**
- C. Stay out from under and away from raised loads.**
- D. Stand clear of cable while pulling. Do not try to guide cable.**
- E. Do not exceed maximum line pull ratings shown in specifications.**
- F. Do not use winch to lift, support, or otherwise transport people.**
- G. A minimum of 5 wraps of cable around the drum barrel is necessary to hold load. Cable set screw is not designed to hold load.**



Techniques of Operation

The best way to get acquainted with how your winch operates is to make test runs before you actually use it. Plan your test in advance. Remember, you hear your winch, as well as see it operate. Get to recognize the sounds of a light steady pull, a heavy pull, and sounds caused by load jerking or shifting. Gain confidence in operating your winch and its use will become second nature with you.

The uneven spooling of cable, while pulling a load, is not a problem, unless there is a cable pileup on one end of drum. If this happens reverse the winch to relieve the load and move your anchor point further to the center of the vehicle. After the job is done you can unspool and rewind for a neat lay of the cable.

The Dow-Lok® clutch provides free spooling and clutch engagement with the cable drum. With the clutch disengaged, the cable can be freespoiled off the drum. For winching in the load the clutch must be fully engaged with the drum.

The Dow-Lok® clutch is latched into either the engaged, "IN" position, or the disengaged "OUT" position, by a pin at the bottom of the shifter handle which fits into latching slots.

TO UNLATCH CLUTCH

Run winch in the reverse (reel out) direction until the load is off the cable, Grasp handle firmly and while pushing on the top of the handle with the thumb for leverage, lift until pin clears latching slots.

TO ENGAGE CLUTCH

Unlatch and pull handle toward "IN" position as far as it will go. In order to attain full engagement, internal elements of the clutch must be aligned. This alignment will take place when the cable drum or cable drum shaft turns a maximum of 1/4 revolution. The clutch will automatically spring into engagement and pin will drop into "IN" slots when this alignment takes place. **Do not attempt to lift a load unless pin is fully into "IN" slots. Keep clear of spring-loaded handle during automatic engagement.**

TO DISENGAGE CLUTCH

Unlatch and push handle to "OUT" position and fully insert pin into latching slots. **Do not disengage the clutch under load.**

The Dow-Lok® air-shifter clutch provides free spooling and clutch engagement with the cable drum. With the clutch disengaged, the cable can be freespoiled off the drum. For winching in the load the clutch must be fully engaged with the drum.

TO ENGAGE CLUTCH

There must be a minimum of 1 foot of slack in the cable before attempting to engage the clutch. This will allow the drum to rotate a minimum of 1/4 turn allowing engagement of the clutch before picking up the load. With this slack in the cable, exhaust air pressure from the air shift cylinder. Run the winch in the "IN" direction until the clutch starts to turn. **Clutch must be fully engaged before starting the winch operation.**

TO DISENGAGE CLUTCH

Run winch in the "OUT" direction until there is no load on the cable. Apply 70-90 psi to the air shift cylinder to disengage the clutch. **Do not disengage the clutch under load.**

The Dow-Lok® low-profile shifter clutch provides free spooling and clutch engagement with the cable drum. With the clutch disengaged, the cable can be freespoiled off the drum. For winching in the load the clutch must be fully engaged with the drum.

TO ENGAGE CLUTCH

Raise the handle so the notch clears the bracket, and pull handle out as far as it will go. The clutch will automatically spring into engagement and latch when the clutch aligns with the drum shaft. In order to attain full engagement, internal elements of the clutch **MUST** be aligned. This alignment will take place when cable drum or cable drum shaft turns a maximum of 1/4 revolution. **Do not attempt to lift a load unless notch in shifter shaft is securely latched. Keep clear of spring-loaded handle during automatic engagement.**

TO DISENGAGE CLUTCH

Raise handle so notch clears bracket. Push handle in and latch the shaft notch onto bracket. **Do not disengage the clutch under load.**

WINCH MAINTENANCE

Adhering to the following maintenance schedule will keep your winch in top condition and performing as it should with a minimum of repair.

A. WEEKLY

1. Check the oil level and maintain it to the oil level plug. If oil is leaking out, determine location and repair.
2. Check the pressure relief plug in top of the gear housing. Be sure that it is in good operating condition so that hot oil gasses may escape.
3. Lubricate cable with light oil.

B. MONTHLY

1. Lubricate the various grease fittings located in the ends of cable drum shaft, end bearing, clutch housing or clutch operating linkage. Any good grade of grease containing moly-disulfide is acceptable.
2. In the case of jaw clutch winches, check the action of the sliding clutch, making sure it is fully engaging and disengaging with the cable drum. Observe the jaws on both the clutch and cable drum, checking for rounding of the driving faces. If rounding has occurred they should be replaced immediately.
3. In the case of Dow-Lok® clutches, check the action of the locking ring. Make sure it is spring loaded and free to move fully against the cable drum in the engaged position and that it is pulled fully away from the cable drum and latched when disengaged.
4. Check the winch mounting bolts. If any are missing, replace them and securely tighten any that are loose. Make sure to use only grade 5 bolts or better.
5. Check the torque setting of the oil cooled worm brake. Make any adjustments required, following the procedure described in ADJUSTING THE OIL COOLED WORM BRAKE in the Owner's Manual.
6. Check alignment of chain and sprockets and adjust as required to minimize wear.
7. Inspect the cable. If the cable has become frayed with broken strands, replace immediately.

C. ANNUALLY

1. Drain the oil from the winch annually or more often if winch is used frequently.
2. Fill the winch to the oil level plug with clean kerosene. Run the winch a few minutes with no load in the reel in direction. Drain the kerosene from the winch.
3. Refill the winch to the oil level plug with all purpose E.P. 140 gear oil.
4. Inspect frame and surrounding structure for cracks or deformation.
5. Gear wear can be estimated by rocking the drum back and forth and if necessary drain oil and remove cover for closer inspection.

WINCH MOUNTING

It is most important that this winch be mounted securely so that the three major sections (the clutch housing end, the cable drum and the gear-housing end) are properly aligned.

All standard H-800 Dow-Lok® series winches are furnished with recommended mounting angles. Angle size is 1/2 x 3 x 4 high strength steel angle.

CABLE INSTALLATION

The Ramsey Model H-800 "Dow-Lok"® winch has two tapered pockets cast into the drum. One pocket is for installations with the wire rope wound over the drum. The other pocket is for an underwound wire rope.

1. Slide the wire rope through narrow end of the pocket against the drum flange.
2. Wrap the wire rope around the anchor "puck" and pull the wire rope and anchor back into the wide end of the pocket.
3. Use a soft hammer to drive the back side of the wire rope, firmly seating the wire rope and anchor, into the pocket.

The wire rope can easily be removed from the drum by driving the anchor out the wide end of the pocket.

The Ramsey Model Y-800/HY-800 ("Y" drum) "Dow-Lok"® winch has a setscrew to secure cable to drum.

Insert the end of cable, opposite hook end, into the 11/16" dia. hole in drum barrel. Secure cable to drum barrel, using set-screw furnished with winch. TIGHTEN SETSCREW SECURELY.

Carefully run the winch in the "reel-in" direction, keeping tension on end of cable, spool all the cable onto the cable drum, taking care to form neatly wrapped layers.

ADJUSTING THE OIL COOLED WORM BRAKE

The oil cooled, fully adjustable, automatic worm brake operates in the worm housing lubricant, all parts being submerged in oil. When the brake wears to the point that the load begins to drift, the brake can be adjusted as follows:

1. Loosen the adjusting screw lock nut.
2. Tighten the brake by turning the adjusting screw clockwise. CAUTION: Only 1/4 turn is usually required to adjust the brake. Over-tightening can cause over-heating, and damage to the brake parts. Tighten the lock nut after adjustment is completed.

If the brake does not respond to adjustment then a new leaf spring and brake disc is needed.

A torque wrench can be equipped with a special adapter to fit the input shaft (worm) of the winch. The adapter can be made by welding a nut to the end of a piece of tubing as shown in the following figure.

After welding the cap and nut to the tubing, slot the tubing, as shown. This will allow the special adapter to slide over the keyway and will then act as a large socket. A torque wrench can be used to apply the proper torque. Turn the torque wrench so that the drum turns in the spool out direction or lowering direction. The torque rating for the brake on the Model H-800 Dow-Lok® should be 50 to 55 ft-lbs. If torque wrench does not show the proper value as it turns, then the worm brake adjusting bolt should be turned clockwise 1/4 turn. Each time the adjusting bolt is turned, check the torque reading. Continue this procedure until the proper torque reading is achieved. Then tighten the lock nut.

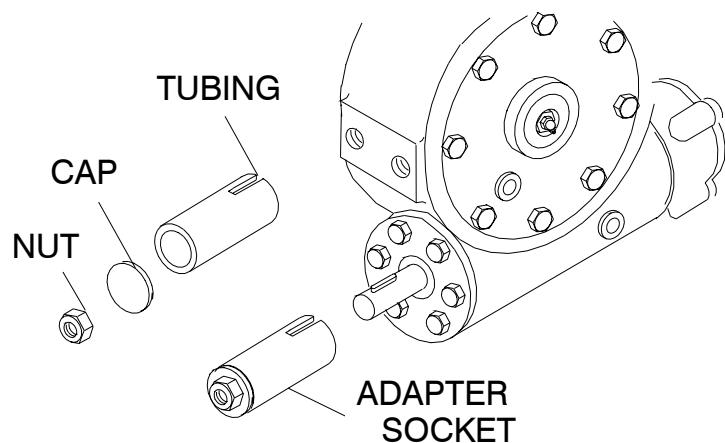

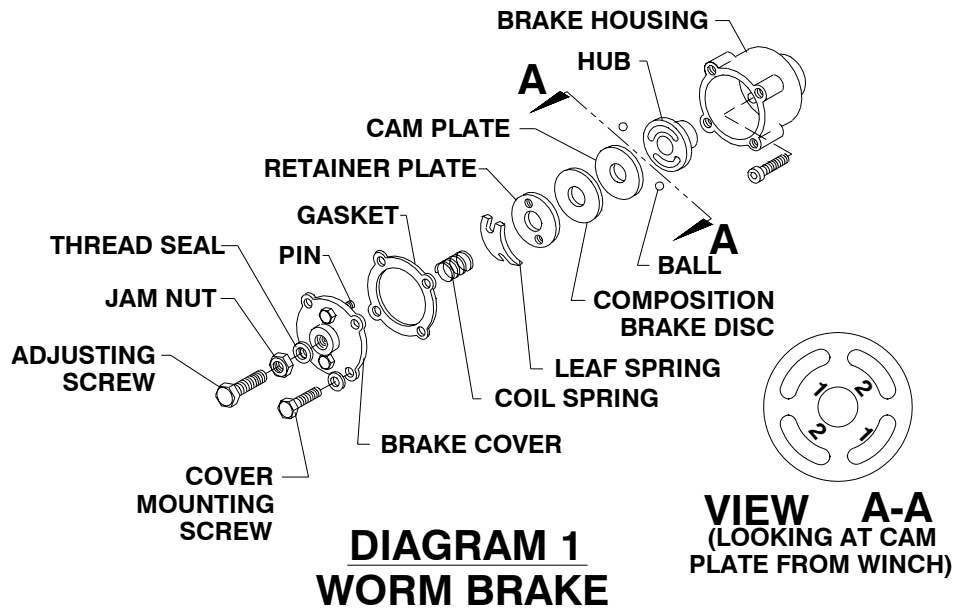

SERVICING OF THE OIL COOLED SAFETY BRAKE

1. Remove the drain plug and drain the worm gear oil from the worm housing.
2. Back off the lock nut, then the adjusting screw, both two turns or more by turning them counter-clockwise.
3. Remove the cover mounting screws.
4. Remove the cover along with coil spring and leaf spring.
5. Remove the retainer plate, composition brake disc, cam plate and balls. Note which slots balls are in.
6. Inspect parts as follows:
 - a) Composition brake discs are 1/4" thick when new. Replace if thinner than 3/16 or if surfaces are glazed or burnt.
 - b) Inspect the flat, ground surface of the cam plate and retainer plate for glazing, warpage, or other damage. Glazing can be removed by scraping carefully.
 - c) Inspect the leaf spring. It should be bowed 1/8".

RE-ASSEMBLING AND CHECKING THE BRAKE

1. Press brake hub into place over worm shaft and key.
2. Assemble balls in appropriate slots of cam. Use stiff grease to hold balls into place and slide cam over end of worm. Be sure that balls are secure, between cam slots and hub slots. See instructions at right to determine proper ball slot setting. Install brake disc.
3. Install retainer plate, smooth side toward brake disc.
4. Install the gasket on the cover with a small amount of grease or sealer.
5. The coil spring goes over the adjusting screw on the inside of the cover.
6. Install the notches of the leaf spring on the pins protruding through the cover. The hollow side of the leaf spring goes toward the brake.
7. Install brake housing cover, making sure the protruding pins go through the leaf spring and into the holes in the retainer plate.
8. Bolt cover into place with the mounting screws. Install drain plug and add 3-3/4 pints all purpose E.P. 140 oil.
9. Turn winch in the hoisting direction at least one turn of the input shaft.
10. Turn the adjusting screw in until it is finger tight.

TEST FOR PROPER BRAKE ASSEMBLY

After the brake has been adjusted to the proper torque setting disengage clutch. Start vehicle engine and run winch in the reel in (hoisting direction). Allow winch to run in this direction for one minute.

Place your hand on the safety brake housing. If housing is not hot to the touch then run winch in the reverse direction (cable out) for one minute. Brake housing should begin to heat.

When these conditions exist, proper installation has been made. If heating becomes noticeable when running the winch in forward rotation (hoisting direction), the brake should be again disassembled. When disassembled, place the brake balls in the alternate set of slots in the cam plates, then carefully follow the instructions for re-assembling and checking the brake.

INSTRUCTIONS FOR CHECKING ASSEMBLY ARRANGEMENT AND SETTING OF WORM BRAKE

When the worm brake is assembled the brake must be set with the balls in the #1 or the #2 set of cam slots. (See View A-A, page 6). It is indicated on the name plate whether the balls were installed in the #1 or the #2 slots at the factory.

Three factors determine which slots the balls should be in:

1. Direction cable winds on the drum. It normally winds over the top of the drum barrel.
2. The cut of the gear set, right or left gear. The last letter in the model number of the winch, either R or L, designates right or left gear set. Example: R-20AR, R-30L, 700R, 800L.
3. The side of the winch that the input shaft is on. The Input Shaft is normally toward the cab. Whether the winch has a gear box on the right or the left side of the winch does not affect the brake setting.

When cable winds over the top of the drum, winch has a right cut gear and input shaft is toward the cab, then the **balls need to be in the #2 cam slots.**

If any one of these three factors differ from those stated above, **the balls need to be in the #1 slots in the cam.** A second change in these factors requires the original arrangement, and if all three factors are different, the balls need to be in the #1 slots.

ADJUSTMENT OF CLUTCH AIR SHIFTER

1. Place winch assembly back into mounting frame and reattach using (8) mounting bolts and lockwashers. Torque mounting hardware to 290 ft. lbs. each. Make sure that gear housing and clutch housing are not rubbing against drum flanges.
2. Place air shifter assembly #5 over shifter shaft aligning clevis over flats of shaft. Secure clevis to shaft using clevis pin #76 and cotter pin #75. Place shifter shaft in the "ENGAGED" position. With the air cylinder shaft fully retracted, push shifter assembly toward the drum until all play is taken out of the shifter shaft. Secure shifter assembly to clutch housing using (4) capscrews #46 (flanged hx. hd. serrated). Tighten securely, but do not torque.
3. Hook up air (70 to 90 psi) to inlet port of air cylinder and disengage clutch. Look into the opening in the clutch housing and verify that the locking ring and retainer plate are not making contact. Locking ring and retainer plate must not make contact. There must be a clearance (gap) of .09 inch (max.) between the locking ring and retainer plate when the winch is fully disengaged. If there is contact, the (4) capscrews #46 should be loosened and the plate pulled away from the drum approximately .06 inch. Tighten screws securely and check action to assure needed clearance. Repeat adjustment procedure as needed to acquire needed gap. Shift clutch 2 or 3 times to verify proper shifting of clutch. After final adjustment, torque (4) capscrews #46 to 18 ft. lbs. each. Attach cover #43 using (4) capscrews #61.

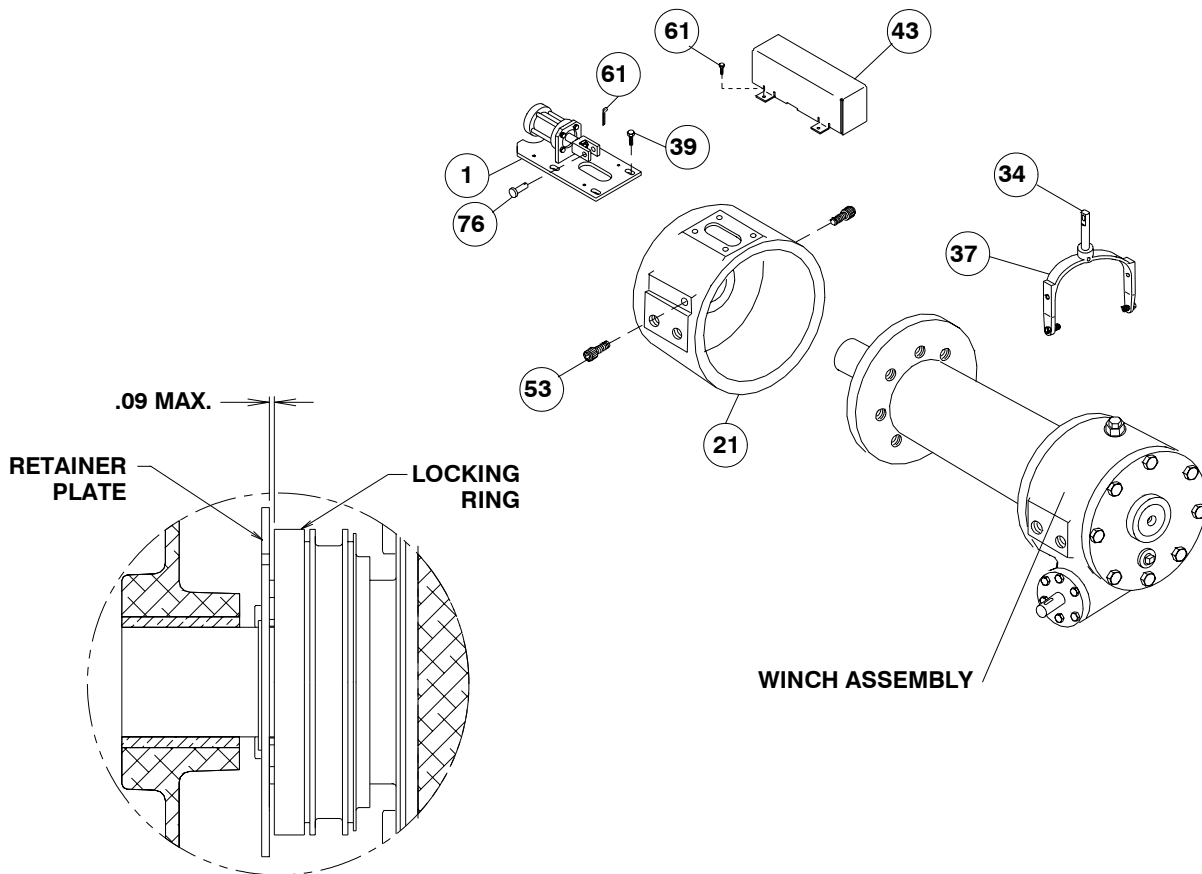

HYDRAULIC SYSTEM REQUIREMENTS

Refer to the performance charts, below, to properly match your hydraulic system to H-800 Dow-Lok® winch performance. The charts consist of :

- (1) Line pull (lb.) first layer vs. working pressure (PSI). STATIC (solid line) refers to hoisting a suspended load from rest; DYNAMIC (dotted line) refers to maintaining the motion of a moving load.
- (2) Line speed, first layer (FPM) vs. Flow, gallons per minute (GPM).

Performance based on a motor displacement of 14.9 cubic inches with 30 GPM maximum flow rate. See page 18 for motor port size.

H-800, HY-800 Series Performance 20,000 lb. Duty Rating 40:1 Gear Ratio

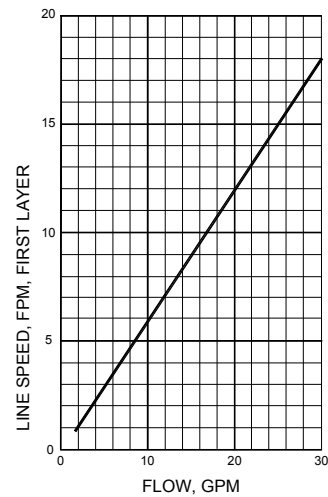
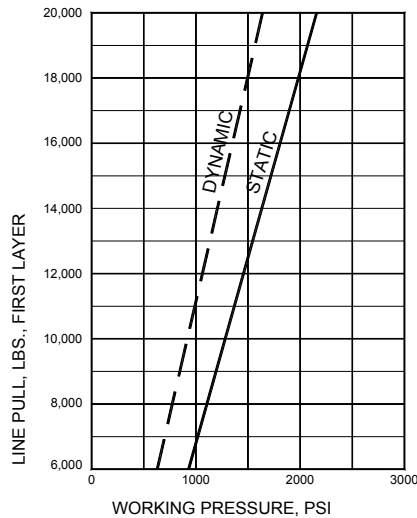

TYPICAL HYDRAULIC LAYOUT

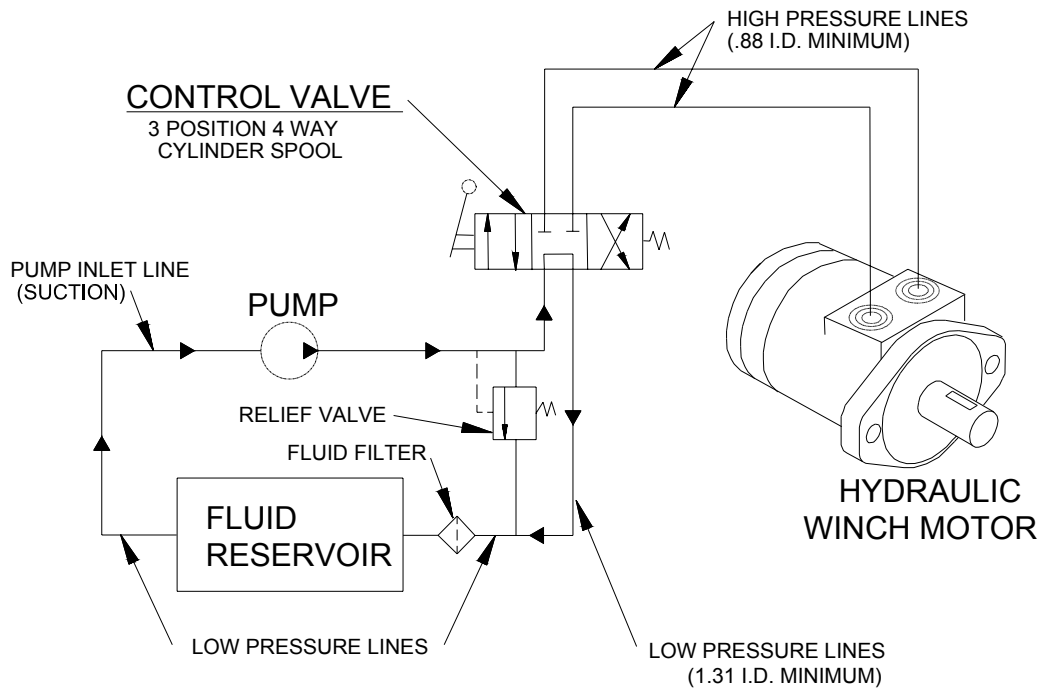

TROUBLESHOOTING GUIDE

CONDITIONS	POSSIBLE CAUSE	CORRECTION
CLUTCH INOPERATIVE OR BINDS UP	<ol style="list-style-type: none"> 1. Dry or rusted shaft. 2. Bent yoke or linkage 	<ol style="list-style-type: none"> 1. Clean and Lubricate. 2. Replace yoke or shaft assembly.
CLUTCH HANDLE WON'T LATCH	<ol style="list-style-type: none"> 1. Debris in clutch. 	<ol style="list-style-type: none"> 1. Clean and lube per page 15.
OIL LEAKS FROM HOUSING	<ol style="list-style-type: none"> 1. Seal damaged or worn. 2. Too much oil. 3. Damaged gasket. 	<ol style="list-style-type: none"> 1. Replace seal. 2. Drain excess oil. Refer to Techniques of Operation. 3. Replace gasket.
LOAD DRIFTS DOWN	<ol style="list-style-type: none"> 1. Worm brake has become worn. 2. Worm brake out of adjustment. 	<ol style="list-style-type: none"> 1. Replace brake disc. (See page 6) 2. Turn adjusting bolt clockwise 1/4 turn or until load does not drift.
WINCH RUNS TOO SLOW	<ol style="list-style-type: none"> 1. Hydraulic motor worn out. 2. Low flow rate. 	<ol style="list-style-type: none"> 1. Replace motor. 2. Check flow rate. Refer to Hydraulic Systems flow chart, page 8.
CABLE DRUM WILL NOT FREESPOOL	<ol style="list-style-type: none"> 1. Winch not mounted squarely, causing end bearings to bind drum. 	<ol style="list-style-type: none"> 1. Check mounting. Refer to Winch Mounting, page 5.
CABLE BIRDNESTS WHEN CLUTCH IS DISENGAGED	<ol style="list-style-type: none"> 1. Drag brake disc worn. 	<ol style="list-style-type: none"> 1. Replace discs.
HYDRAULIC FLUID LEAKS FROM HOLE IN ADAPTER	<ol style="list-style-type: none"> 1. Damaged motor shaft seal. 	<ol style="list-style-type: none"> 1. Replace seal.

INSTRUCTIONS FOR OVERHAUL OF RAMSEY MODEL H-800 DOW-LOK®

Dis-assembly

Refer to parts list and parts drawing pages for actual item numbers and corresponding parts numbers.

(1)

Drain oil from gear housing by removing pipe plug (item #63) from gear housing.

Shift clutch into the engaged "IN" position.

Remove frame angles (item #2) from winch assembly.

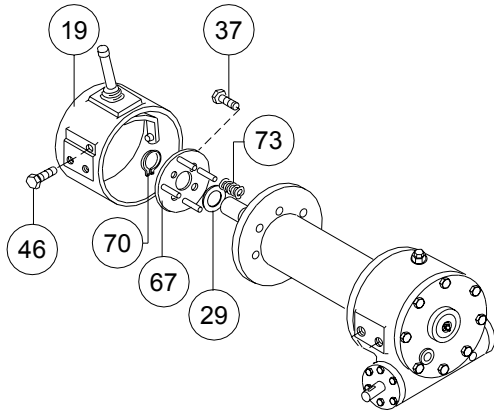
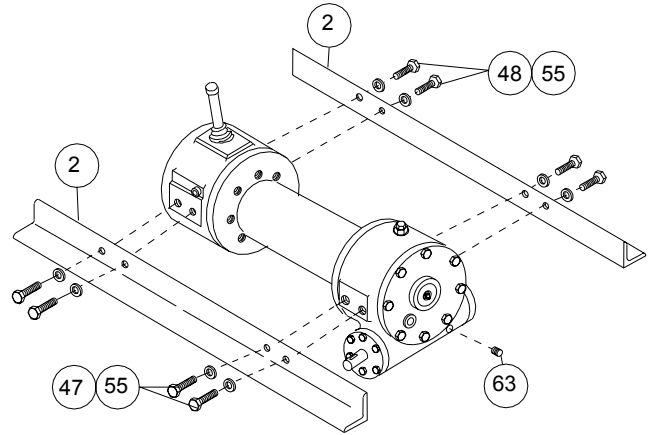

(2)

Remove two capscrews (item #46) from clutch housing (item #19) and unlatch shifter assembly.

Remove clutch housing from end of drum shaft. Press in on retainer plate (item #67), to relieve the spring tension and remove the retainer ring (item #70).

Remove four capscrews (item #37), retainer plate (item #67), springs (item #73) and spacer (item #29).

(3)

Slide the locking ring (item #10) from the clutch. NOTE: The locking ring cannot be removed unless the clutch is engaged, with dowel pins (item #65) seated in the shaft keyways.

Rotate the drum so the eight balls (item #33) and four dowel pins (item #65) can be removed.

If necessary, the clutch (item #9) may be disassembled from the drum by removing eight capscrews (item #43). Slide drum (item #14) from drum shaft.

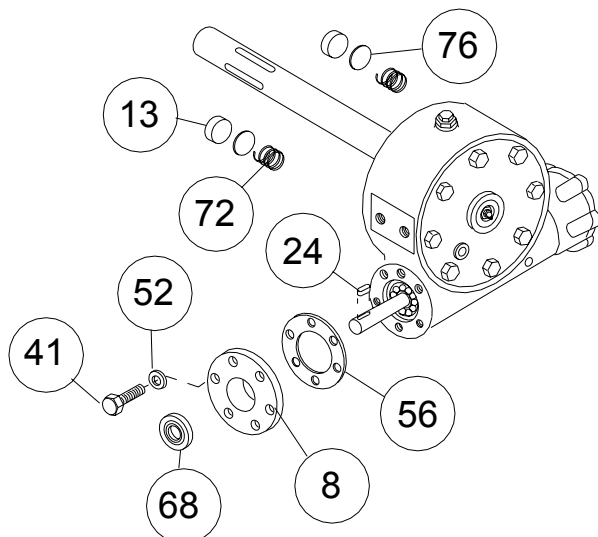
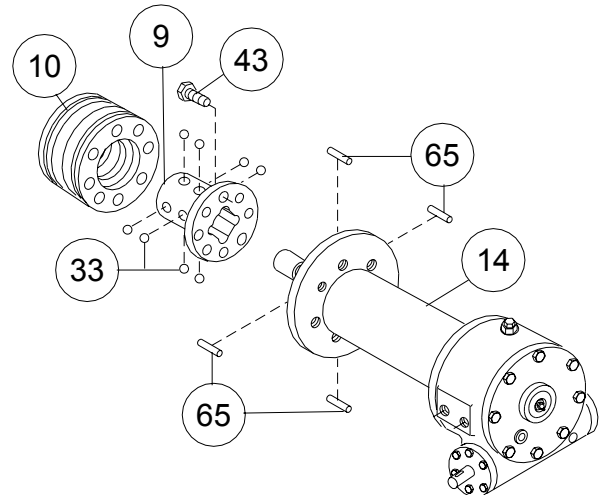

(4)

Remove key (item #24) from worm shaft.

Remove bearing cap (item #8) and gasket (item #56) by unscrewing six capscrews (item #41) and lockwashers (item #52).

Remove seal (item #68) from bearing cap and press new seal into place.

Drag brake disc (item #13), spacer (item #76) and spring (item #72) should be examined and replaced if necessary.

(5)

Remove motor (item #62) from adapter plate (item #26) by removing capscrews (item #51). Remove adapter plate and coupling (item #2) from adapter (item #3) by unscrewing eight capscrews (item #48).

Remove key (item #24) from worm shaft. Unscrew six capscrews (item #50) and remove adapter from gear housing. Replace adapter seal (item #70) and gasket (item #57).

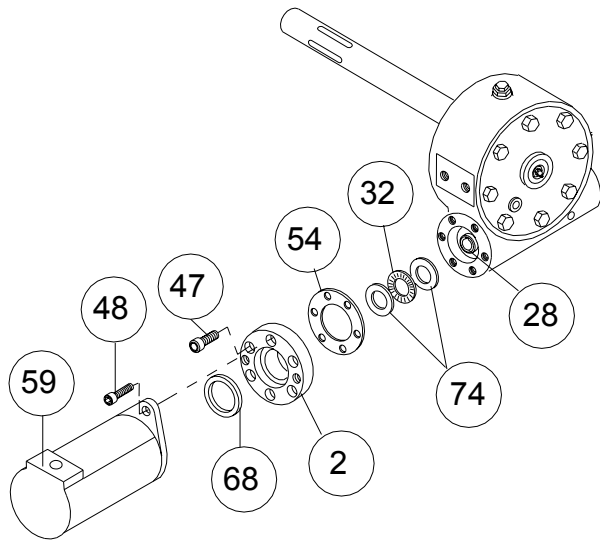
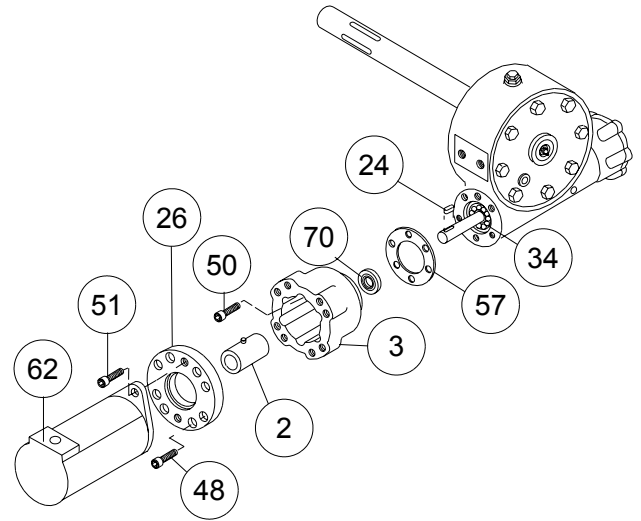

(5a)

Remove motor (item #59) from adapter (item #2) by removing two capscrews and lockwashers (item #48 & #52). Remove adapter (item #2) from gear housing by removing six (item #47) capscrews. Replace pilot seal (item #68) and gasket (item #54). Remove thrust bearing (item #32) and thrust washers (item #74).

(6)

Refer to page 5, SERVICING OIL COOLED SAFETY BRAKE. Remove brake housing (item #18) from gear housing by unscrewing six (item #49) capscrews. Remove key (item #23) from worm. Remove worm (item #30) and bearings (item #34) from gear housing. Use a soft hammer to gently tap input end of worm and drive worm and bearing from gear housing. Once worm has been removed from housing, bearing can be pressed from end of worm.

Check for signs of wear or damage to worm (item #30) and bearings (item #34). Replace if necessary.

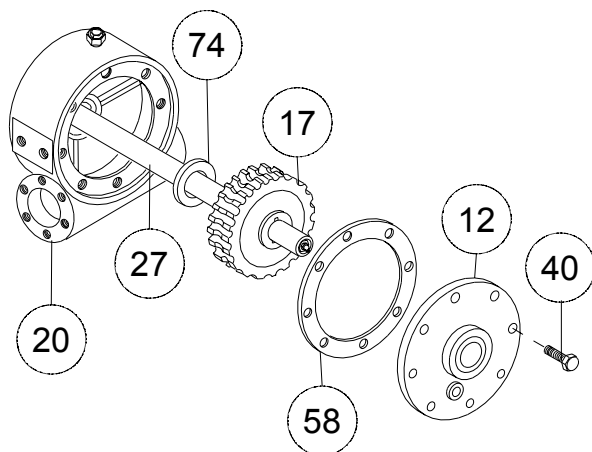
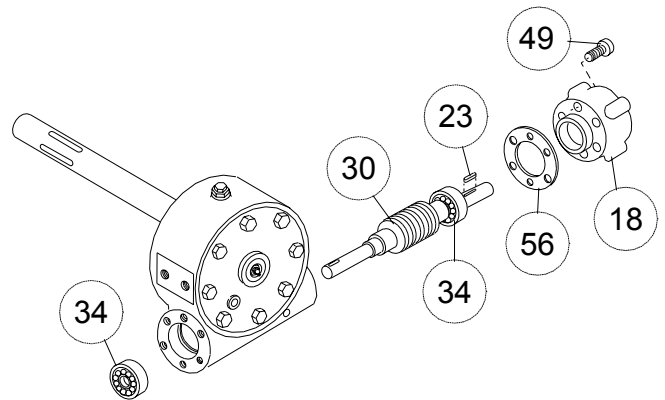

(7)

Remove gear housing cover (item #12) from gear housing (item #20) by unscrewing eight capscrews (item #40). Thread two of the capscrews into the two tapped holes of cover and tighten. This will pull the cover loose from gear housing.

Remove cover gasket (item #58) and pull shaft (item #27), with gear (item #17) and spacer (item #74) attached, from gear housing.

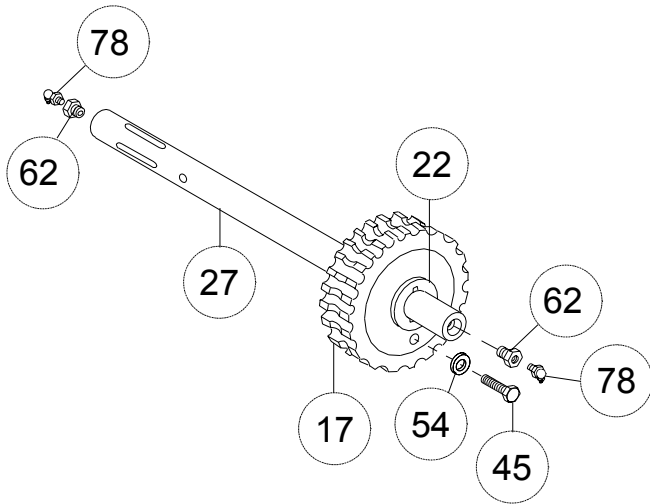

(8)

Check for signs of wear on gear teeth. If necessary, replace gear.

Check lube fittings (item #78) for damage and replace if necessary. Remove lube fittings (item #78) and reducers (item #62) from ends of shaft, if following Step 9, and reinstall after Step 9.

(9)

If shaft and/or gear hub is damaged, replace as follows:

- a. Tap keys (item #25) into short keyways of drum shaft (item #27).
- b. Press shaft (item #27) and keys through gear hub (item #17) until end of keys on long end of shaft are flush with hub.

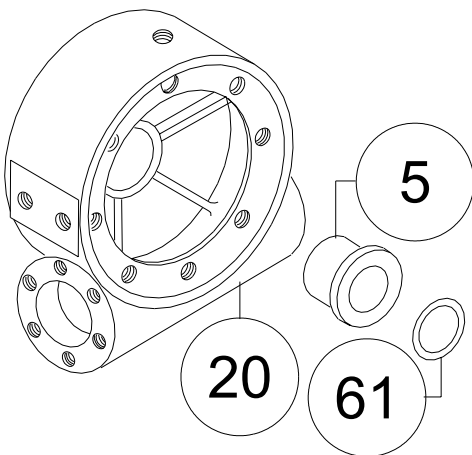
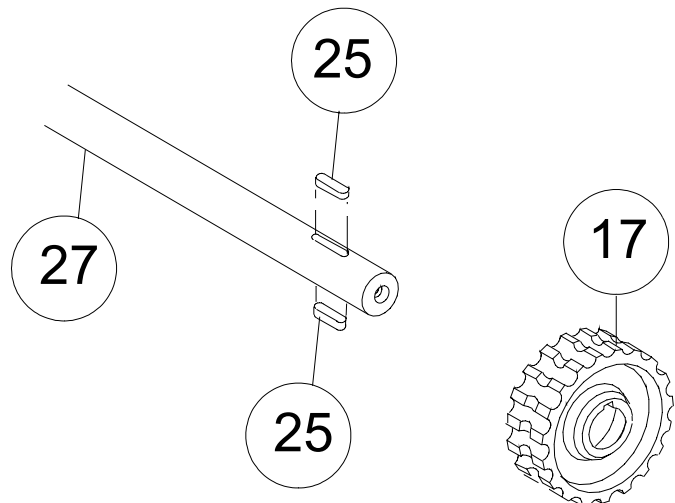

(10)

Check gear housing bushing (item #5) and o-ring (item #63) for signs of wear. Replace if necessary by pressing old bushing from gear housing (item #20). Press new bushing into place and insert new o-ring (item #61) into groove inside of bushing.

(11)

Check drum bushings (items #35 & #36) for signs of wear. Replace if necessary by pressing old bushings from drum (item #14). Press bushing (item #35) into bore in drum until its flange is seated against bottom of counter-bore. Press bushing (item #36) into opposite bore on drum until end of bushing extends .50" from end of drum.

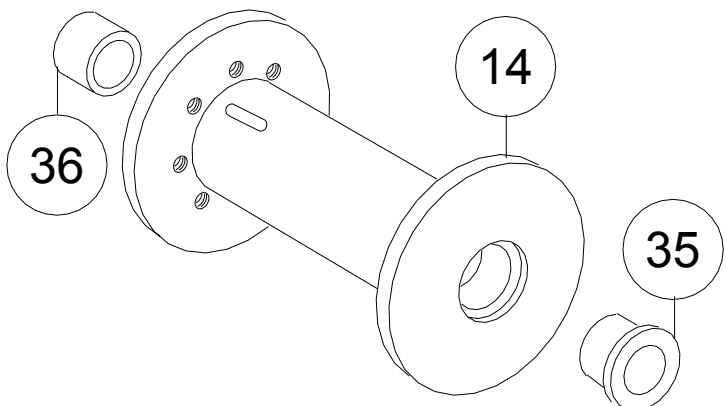

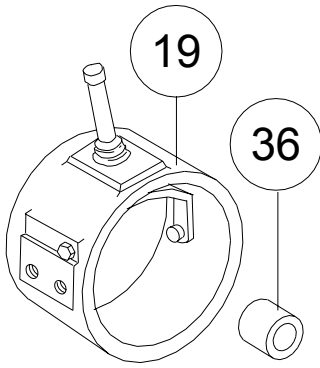

(12)

Check end bearing bushing (item #36) for signs of wear. If necessary, remove old bushing and press new bushing into place.

(13)

Check cover bushing (item #5) and o-ring (item #61) for signs of wear. Replace if necessary by pressing old bushing from gear housing cover (item #12). Press new bushing into place and insert new o-ring (item #61) into groove inside of bushing.

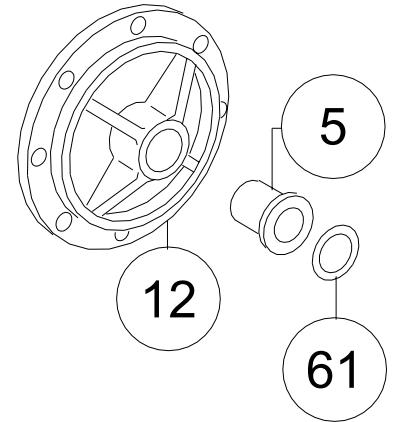

RE-ASSEMBLY

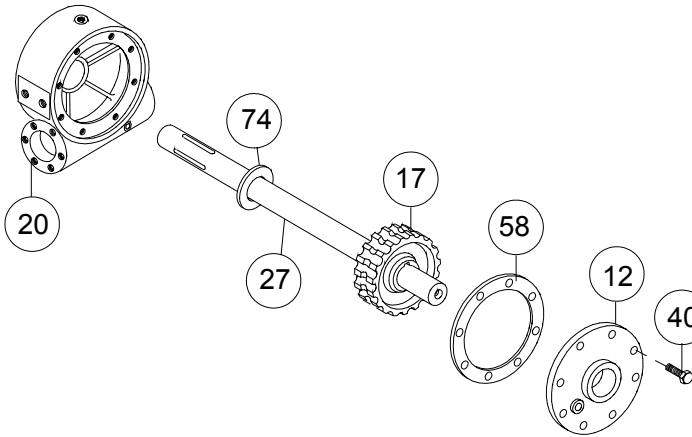

(14)

Slide spacer (item #74) over long end of shaft and place against gear hub. Apply grease to end of shaft, opposite gear. Apply grease to bushing in gear housing (item #20). Place greased end of shaft through bushing in gear housing (item #20). Place gasket (item #58) onto gear housing cover (item #12). Apply grease to gear end of shaft and cover bushing. Place cover onto shaft and secure to housing with eight (item #40) cap screws. Tighten cap screws to 39 ft. lb. (52 Nm.) each.

(15)

Press bearing (item #34) onto worm (item #30).
NOTE: Be sure that thick shoulder of bearings outer race (side with manufacturer's name and part number) is out, away from worm threads. Press bearing and worm into gear housing. Slip gasket (item #56) onto brake housing (item #18). Use six cap screws (item #49) to secure brake housing to gear housing. Tighten cap screws to 45 ft. lb. (61 Nm.) each.

Place key (item #23) into keyway of worm (item #30). Refer to page 6 for reassembly and checking of worm brake.

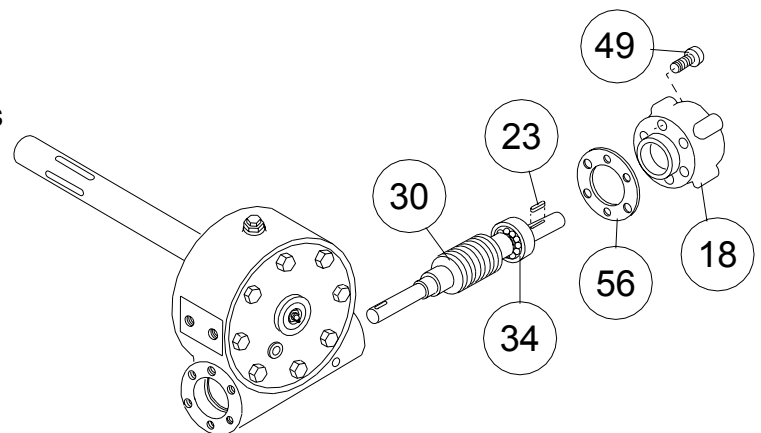

(16)

Press bearing (item #34) onto worm and into housing. **NOTE:** Be sure that thick shoulder of bearings outer race (side with manufacturer's name and part number) is out, away from worm threads. Attach bearing cap (item #8) to gear housing using six capscrews (item #41) with lockwashers (item #52). Tighten capscrews to 39 ft. lb. (52 Nm.) each. Insert key (item #24) into keyway of worm shaft.

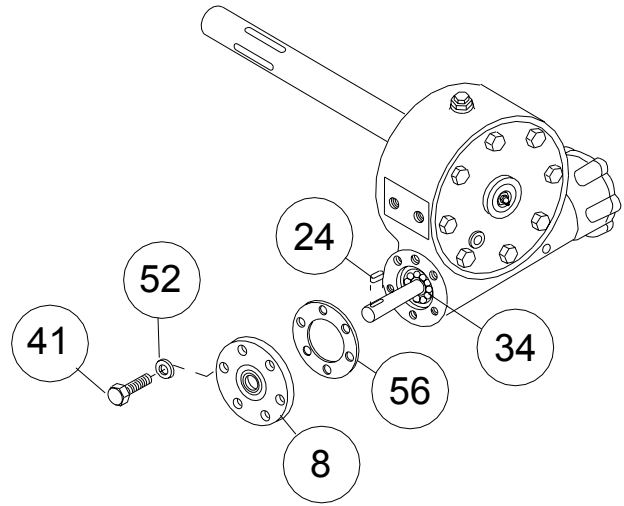

(17)

Press bearing (item #34) onto worm and into housing. **NOTE:** Be sure that thick shoulder of bearings outer race (side with manufacturer's name and part number) is out, away from worm threads. Attach adapter (item #3) to gear housing using six capscrews (item #50). Tighten capscrews to 45 ft. lb. (61 Nm.) each. Insert key (item #24) into keyway of worm shaft. Slide coupling (item #2) over end of worm shaft. Attach adapter plate (item #26) to adapter using eight capscrews (item #48). Tighten capscrews to 21 ft. lb. (28 Nm.) each.

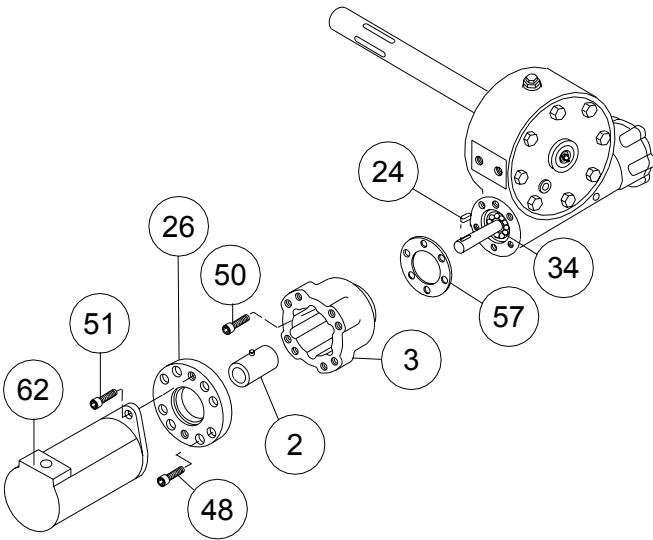

Place motor shaft, with key in keyway, into coupling. Secure motor (item #62) to adapter, using two capscrews (item #51). Tighten capscrews to 102 ft. lb. (138 Nm.) each.

(17a)

Place thrust washers (item #74) and thrust bearing (item #32) over end of worm (item #28) and into housing. Attach adapter (item #2) with gasket (item #54) to housing, using six (item #47) capscrews. Tighten capscrews to 45 ft.lb. (61Nm.) each.

Insert pilot seal (item #68) into adapter and carefully place motor shaft, with key in keyway, through seal, so as not to damage seal. Insert motor shaft into end of worm (item #28). Secure motor (item #59) to coupling using two (item #48) capscrews with lockwashers (item #52). Tighten capscrews to 102 ft.lbs. (138 Nm.) each.

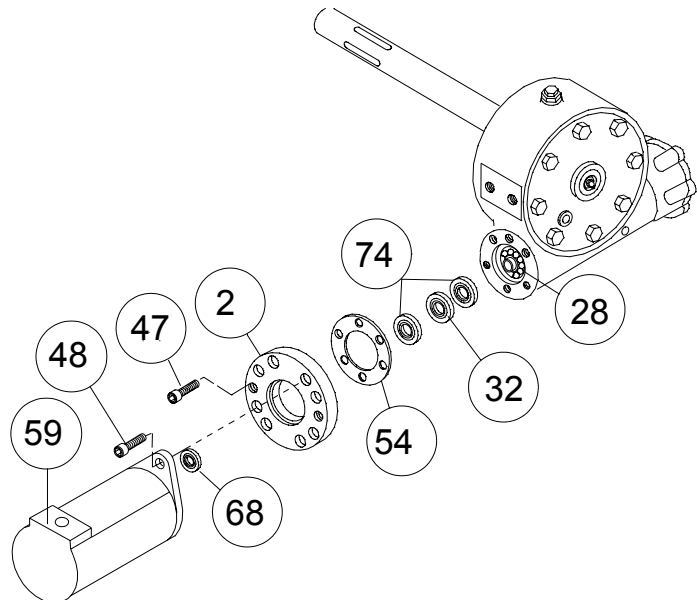

(18)

Place winch with gear housing cover down on work bench. Drum shaft should be in vertical position. Set springs (item #72) into pockets of gear housing with drag brakes (item #13) on top of disc (item #76) and springs. Slide drum assembly (item #14) onto drum shaft as shown.

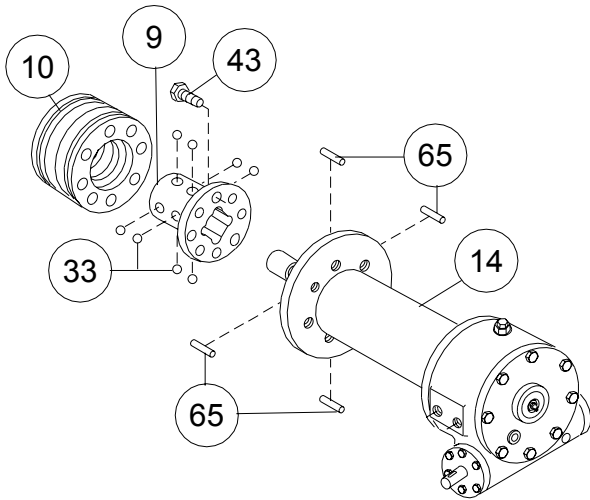

(19)

Place clutch (item #9) over end of drum shaft. Align the clutch over the pilot bushing in drum. Install the eight cap screws (item #43) and torque the cap screws to 103 ft. lb. (139 Nm.) to securely seat the clutch to the drum.

Rotate the drum to align the clutch slots with the shaft keyways. Lightly grease four dowel pins (item #65) and eight balls (item #33). Use molybdenum disulfide or graphite bearing grease. Insert the four dowel pins (item #65) and eight balls (item #33). In the engaged position the balls are nearly flush with the clutch.

Lightly grease the internal and external groove and bore in locking ring (item #10) and clutch (item #9).

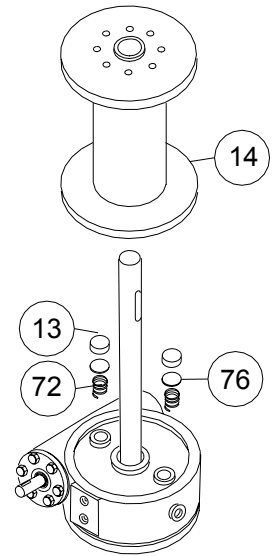

Slide locking ring onto the clutch. When fully engaged, the locking ring touches the clutch flange and there is .71 to .73 inches between the end of the locking ring and the end of the clutch.

(20)

Place four springs (item #73) over four roll pins on retainer plate (item #67). Install spacer (item #29) and retainer plate and secure to clutch using four cap screws (item #37). Tighten capscrews to 9.7 ft. lb. (13 Nm.) each. Firmly seat the retainer ring (item #70) into drum shaft groove.

Set the shifter assembly so that the screw heads engage the external groove in the locking ring (item #10). Push the clutch housing (item #19) onto the drum shaft and latch the shifter assembly in the engaged "IN" position. Insert the two capscrews (item #46).

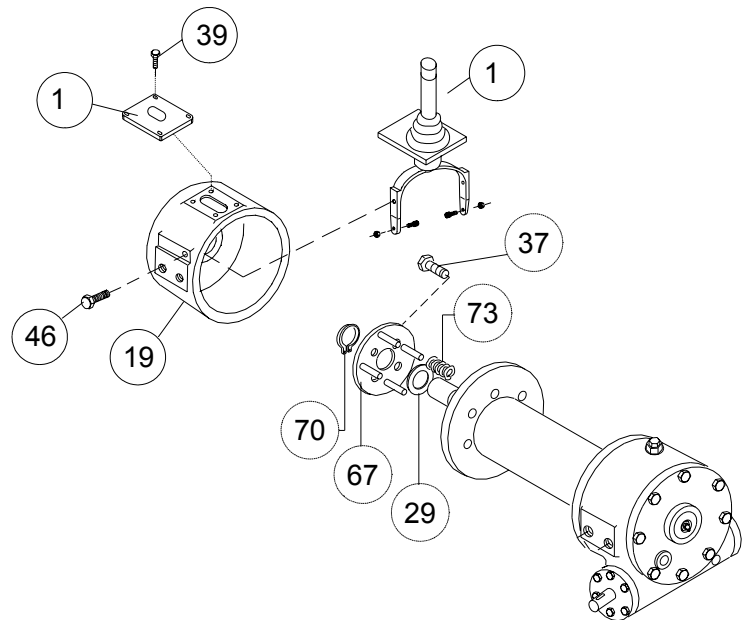

(21)

Attach mounting angles (item #2) to winch assembly. Use capscrews (item #47 & #48) and lockwashers (item #55). Tighten capscrews to 290 ft. lb. (393 Nm) each. Insert plug (item #63) into hole in bottom of gear housing. Remove plugs (items #59 & 62) from top of housing. Pour 3 -3/4 pints of E.P. 140 oil into hole and replace plugs.

Check the action of the clutch by shifting and freespooling the winch drum several times.

The shift pattern plate on top of the clutch housing is adjusted at the factory to provide reliable shifting of the Dow-Lok® clutch. If the plate should loosen or be removed, you must readjust the plate. Shift the handle to disengage the clutch and hold against the internal stop. With the latching pin in the "OUT" slots, push the shift pattern plate toward the cable drum. Unsnap plastic lever cover from pattern plate. Tighten the four capscrews which hold the plate to housing. Snap lever cover back into place around the pattern plate.

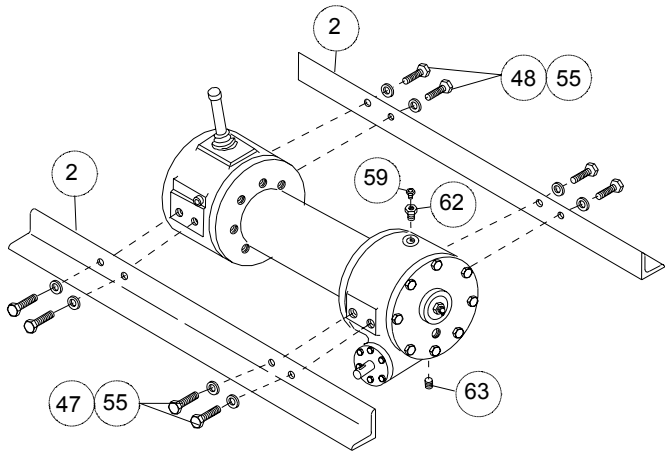

Model 800 Dow-Iok® 800 / Y-800

WINCH MODEL	A INCHES MM	B INCHES MM	C INCHES MM	D INCHES MM	E INCHES MM	F INCHES MM
800	10.62 269,7	15.00 381,0	10.75 273,0	19.38 492,2	2.09 53,0	5.69 144,5
Y-800	7.75 196,8	9.44 239,8	13.68 347,4	13.63 346,2	2.00 50,8	5.50 139,7

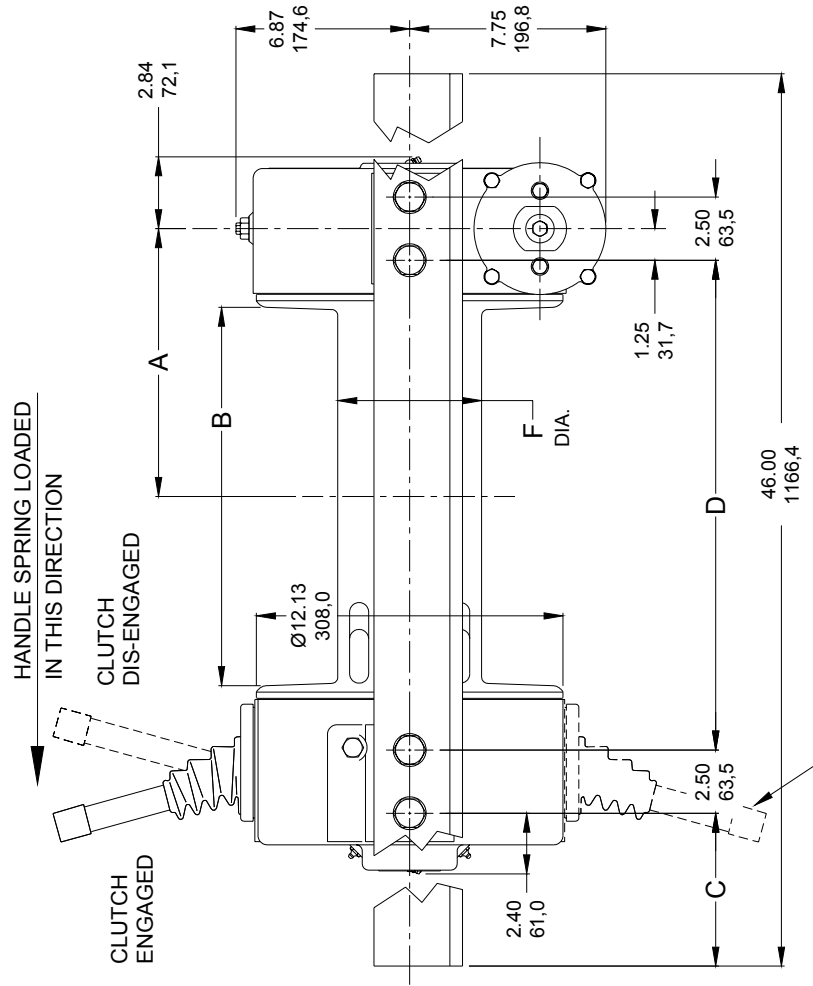
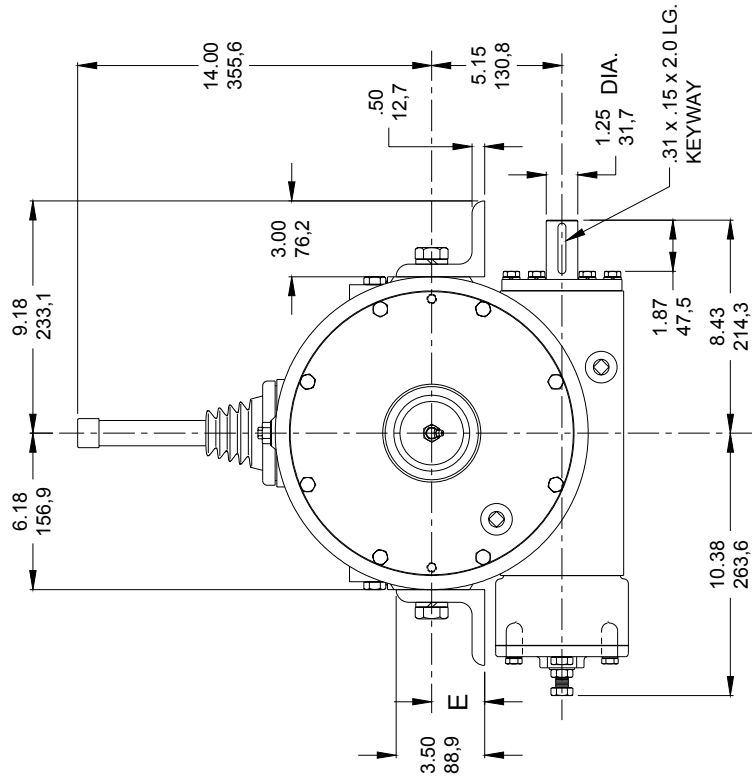

DIMENSIONS SHOWN ARE INCHES OVER MILLIMETERS

Model 800 Dow-Iok® H-800 / HY-800

WINCH MODEL	A INCHES MM	B INCHES MM	C INCHES MM	D INCHES MM	E INCHES MM	F INCHES MM
H-800	10.62 269,7	15.00 381,0	13.81 350,7	19.38 492,2	52.00 1320,8	5.69 144,5
HY-800	7.75 196,8	9.44 239,8	13.68 347,4	13.63 346,2	46.00 1168,4	5.50 139,7

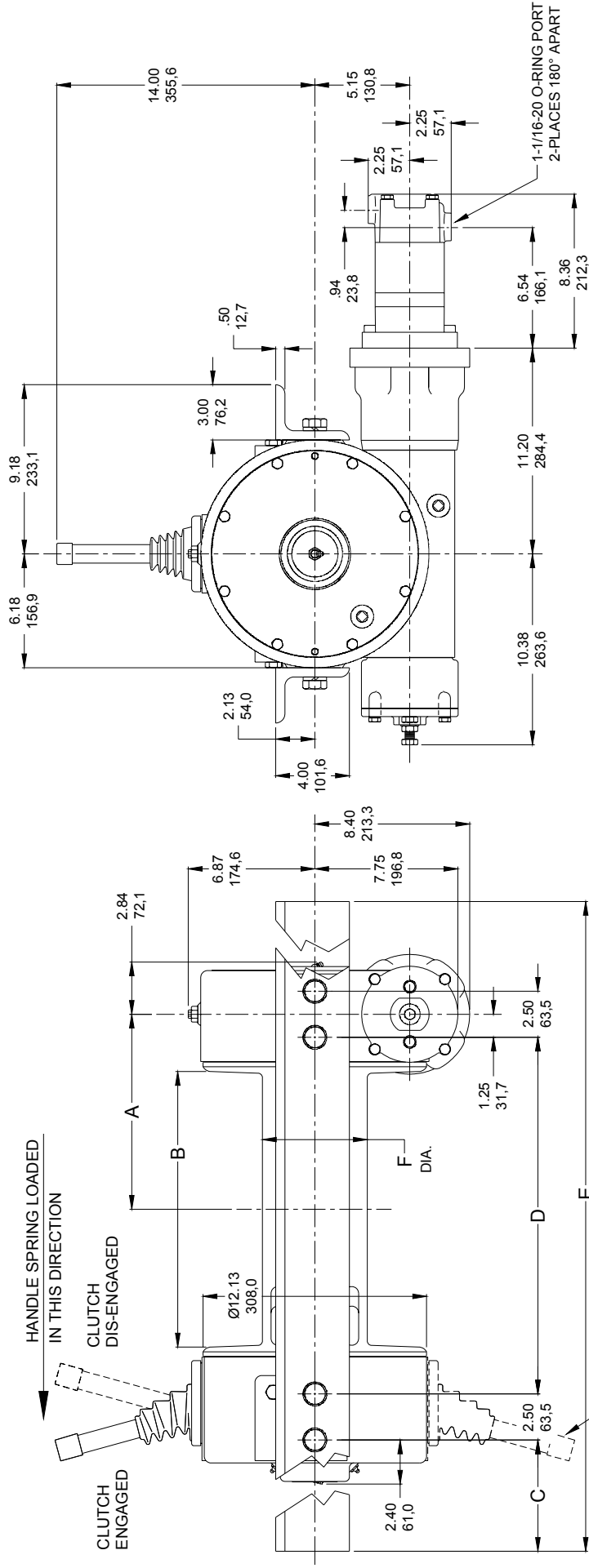

DIMENSIONS SHOWN ARE INCHES OVER MILLIMETERS

Model 800 Dow-Iok® H-800 / HY-800 SHORT COUPLING

WINCH MODEL	A INCHES MM	B INCHES MM	C INCHES MM	D INCHES MM	E INCHES MM	F INCHES MM
H-800	10.62 269.7	15.00 381.0	13.81 350.7	19.38 492.2	52.00 1320.8	5.69 144.5
HY-800	7.75 196.8	9.44 239.8	13.68 347.4	13.63 346.2	46.00 1168.4	5.50 139.7

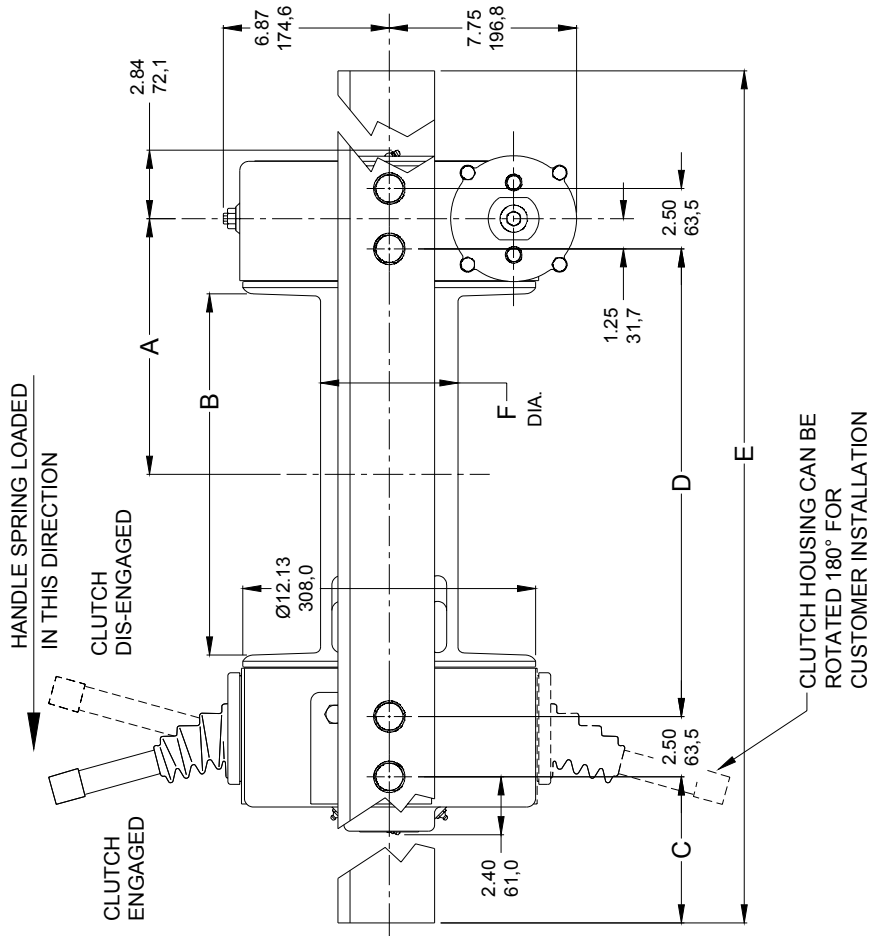
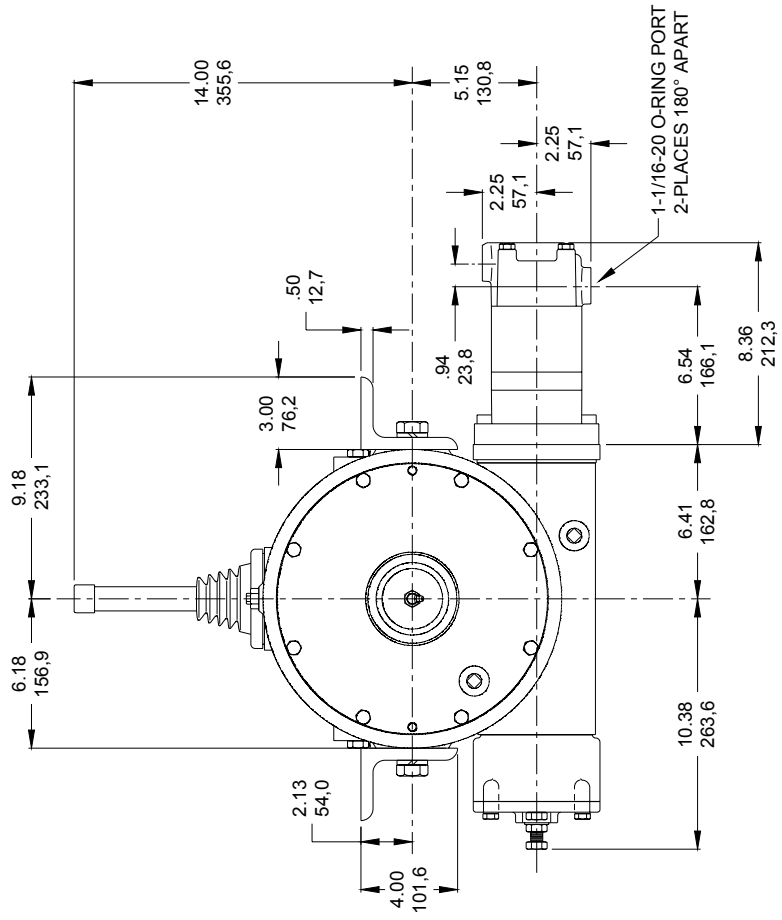

DIMENSIONS SHOWN ARE INCHES OVER MILLIMETERS

Model 800 Dow-Iok® H-800 / HY-800 AIR SHIFTER

WINCH MODEL	A INCHES MM	B INCHES MM	C INCHES MM	D INCHES MM	E INCHES MM	F INCHES MM
H-800	10.62 269.7	15.00 381.0	13.81 350.7	19.38 492.2	52.00 1320.8	5.69 144.5
HY-800	7.75 196.8	9.44 239.8	13.68 347.4	13.63 346.2	46.00 1168.4	5.50 139.7

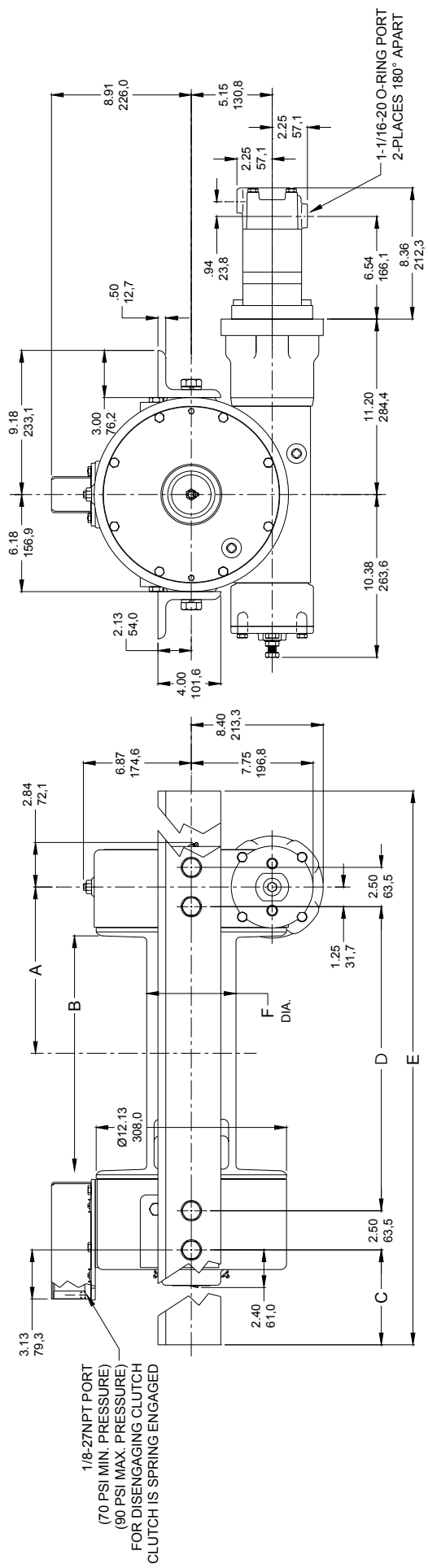

DIMENSIONS SHOWN ARE INCHES OVER MILLIMETERS

**Model 800 Dow-Iok®
H-800 / HY-800 SHORT COUPLING LOW-PROFILE SHIFTER**

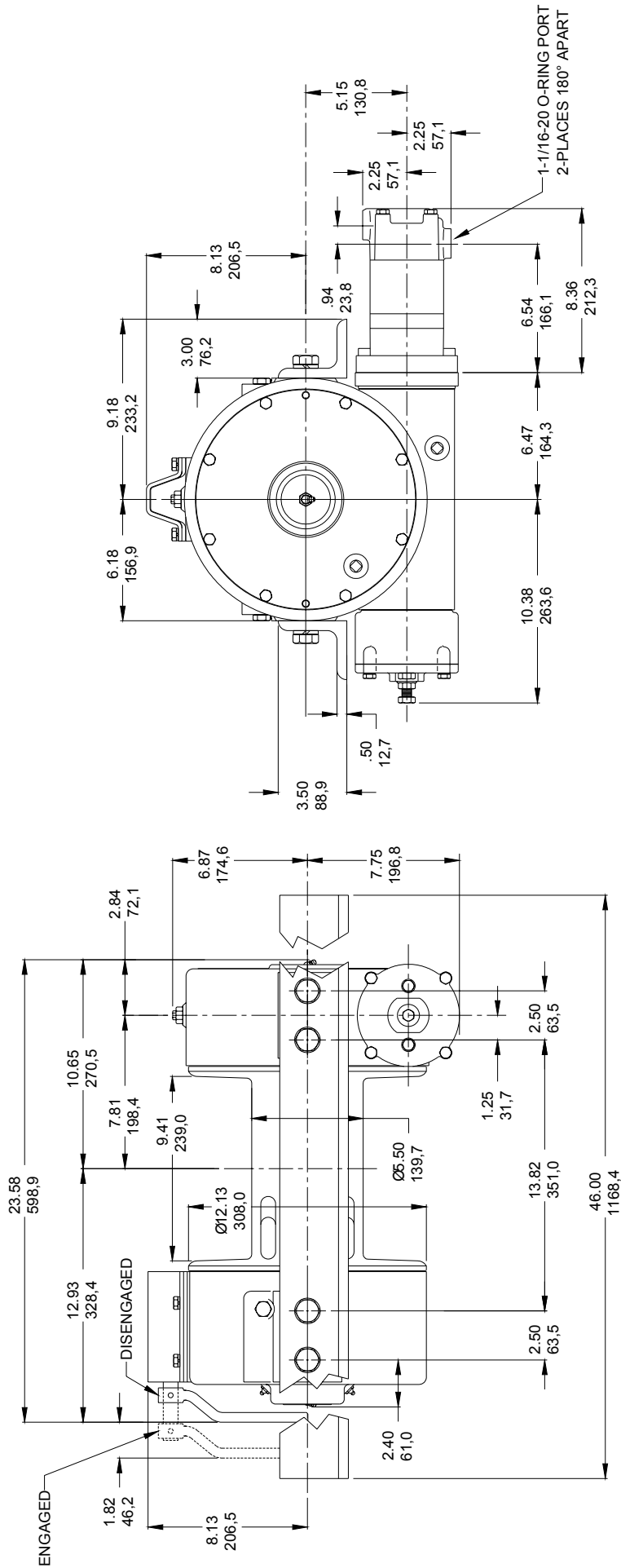

DIMENSIONS SHOWN ARE INCHES OVER MILLIMETERS

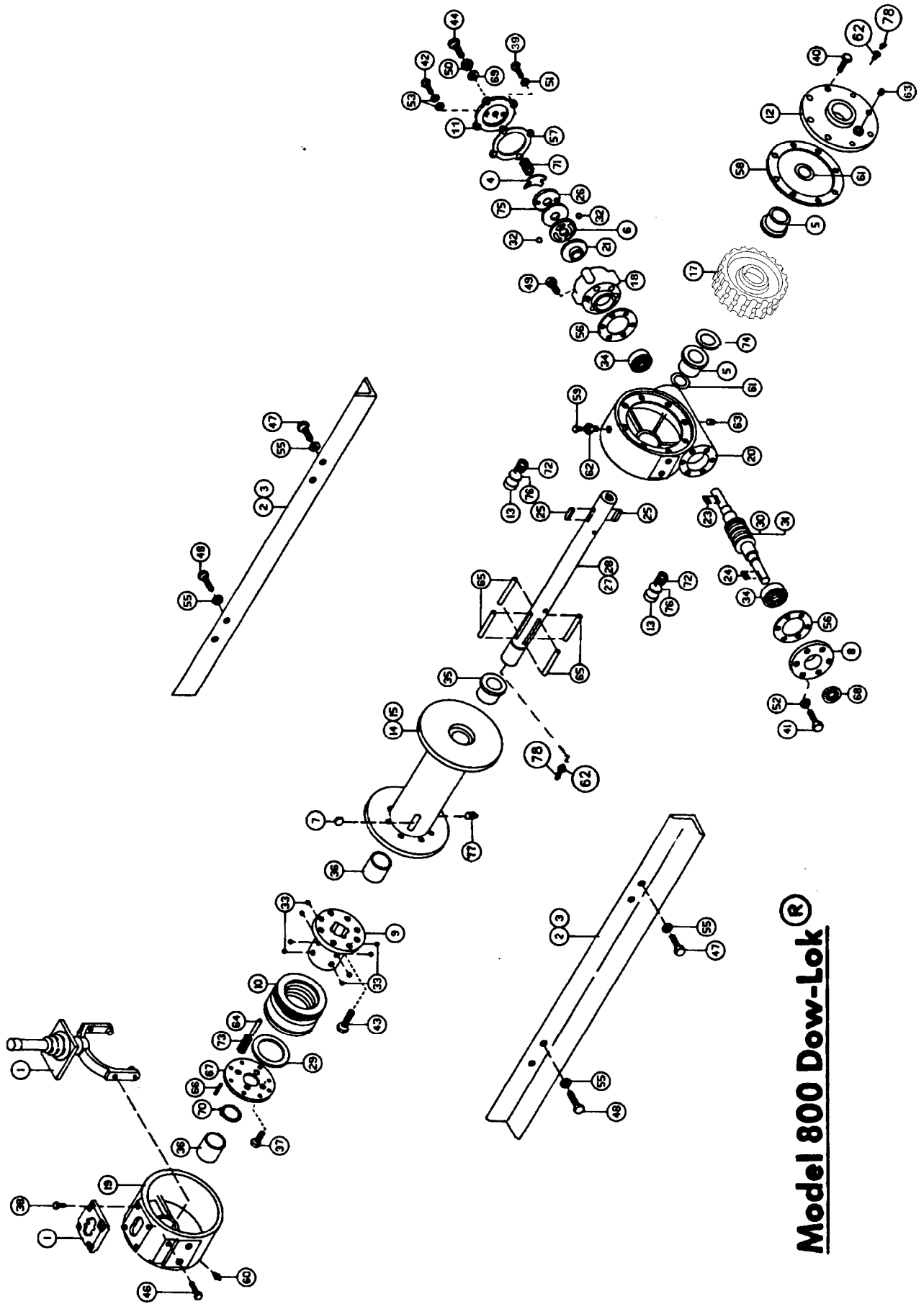

Model 800 Dow-Lok®

PARTS LIST MODEL 800 DOW-LOK®

Item No.	Qty.	Parts No.	Description	Item No.	Qty.	Parts No.	Description
1	1	276033	SHIFTER ASSEMBLY	40	8	414277	CAPSCREW 3/8-16NC X 1 LG HX HD GR5 NYLOK HVY P
2	2	302093	ANGLE - Y800	41	6	414282	CAPSCREW 3/8-16NC X 1-1/4 LG HX HD DR5
3	2	302111	ANGLE - STD.	42	2	414399	CAPSCREW 3/8-24NF X 1-1/4 LG ALL-THRD GR5
4	1	306035	SPRING - FLAT	43	8	414571	CAPSCREW 1/2-20NF X 1 LG HX HD GR5
5	2	308083	BUSHING	44	1	414603	CAPSCREW 1/2-20NF X 1-3/4 LG ALL-THRD GR5
6	1	314007	CAM PLATE				
7	1	314010	CABLE ANCHOR ("STD." DRUM ONLY	46	2	414619	CAPSCREW 1/2-13NC X 2-1/2 LG HX HD ALL-THRD ZP
8	1	316006	CAP BEARING	47	4	414751	CAPSCREW 3/4-10NC X 1-3/4 GR5 NYLOK HVY PATCH
9	1	324151	CLUTCH	48	4	414777	CAPSCREW 3/4-10NC X 1-3/4 GR5
10	1	324318	LOCKING RING	49	6	414897	CAPSCREW 3/8-16NC X 1 LG SOC HD
11	1	328027	COVER - BRAKE	50	1	418067	NUT 1/2-20NF HX JAM
12	1	328122	COVER - GEAR HOUSING	51	4	418163	LOCKWASHER 5/16 MED SECT PLTD
13	2	330010	SHOE - DRAG BRAKE	52	6	418177	LOCKWASHER 3/8 MED SECT PLTD
14	1	332167	DRUM (STANDARD)	53	4	418184	WASHER - FLAT 3/8 ALUM
15	1	332172	DRUM ("Y" 800)				
16	1	334189	GEAR - L.H.	55	8	418249	LOCKWASHER 3/4 MED SECT
17	1	334188	GEAR - R.H.	56	2	442192	GASKET
18	1	338221	HOUSING - BRAKE	57	1	442194	GASKET
19	1	338235	HOUSING - CLUTCH	58	1	442195	GASKET
20	1	338242	HOUSING - GEAR	59	1	456008	FITTING - RELIEF
21	1	340011	HUB - BRAKE	60	1	456031	FITTING - LUBE
23	1	342053	KEY	61	2	462013	QUAD-RING
24	1	342092	KEY	62	3	468002	REDUCER
25	2	342153	KEY	63	2	468011	PIPE PLUG
26	1	352021	PLATE - RETAINER	64	4	470042	PIN - ROLL
27	1	357498	SHAFT - DRUM (STD.)	65	4	470044	PIN - DOWEL
28	1	357502	SHAFT - DRUM (Y800)	66	4	470056	PIN - ROLL
29	1	362224	SPACER	67	1	474030	PLATE - RETAINER
30	1	368082	WORM R.H.	68	1	486068	SEAL - OIL
31	1	368084	WORM L.H.	69	1	486076	THREAD SEAL
32	2	400007	BALL - BRAKE	70	1	490025	RING - RETAINER
33	8	400011	BALL - CLUTCH	71	1	494010	SPRING
34	2	402045	BEARING - BALL	72	2	494022	SPRING - DISC
35	1	412051	BUSHING	73	4	494069	SPRING
36	2	412052	BUSHING	74	1	518016	THRUST WASHER
37	4	414038	CAPSCREW 1/4-20NC X 3/4 LG HX HD GR5	75	1	530007	DISC - BRAKE
38	4	414069	CAPSCREW 5/16-18NC X 3/4 LG HX HD	76	2	530094	SPACER - BRAKE
39	4	414111	CAPSCREW 5/15-18NC X 1 LG HX HD GR5	77	1	416059	SETSCREW ("Y" DRUM ONLY)
				78	2	456039	LUBE FITTING

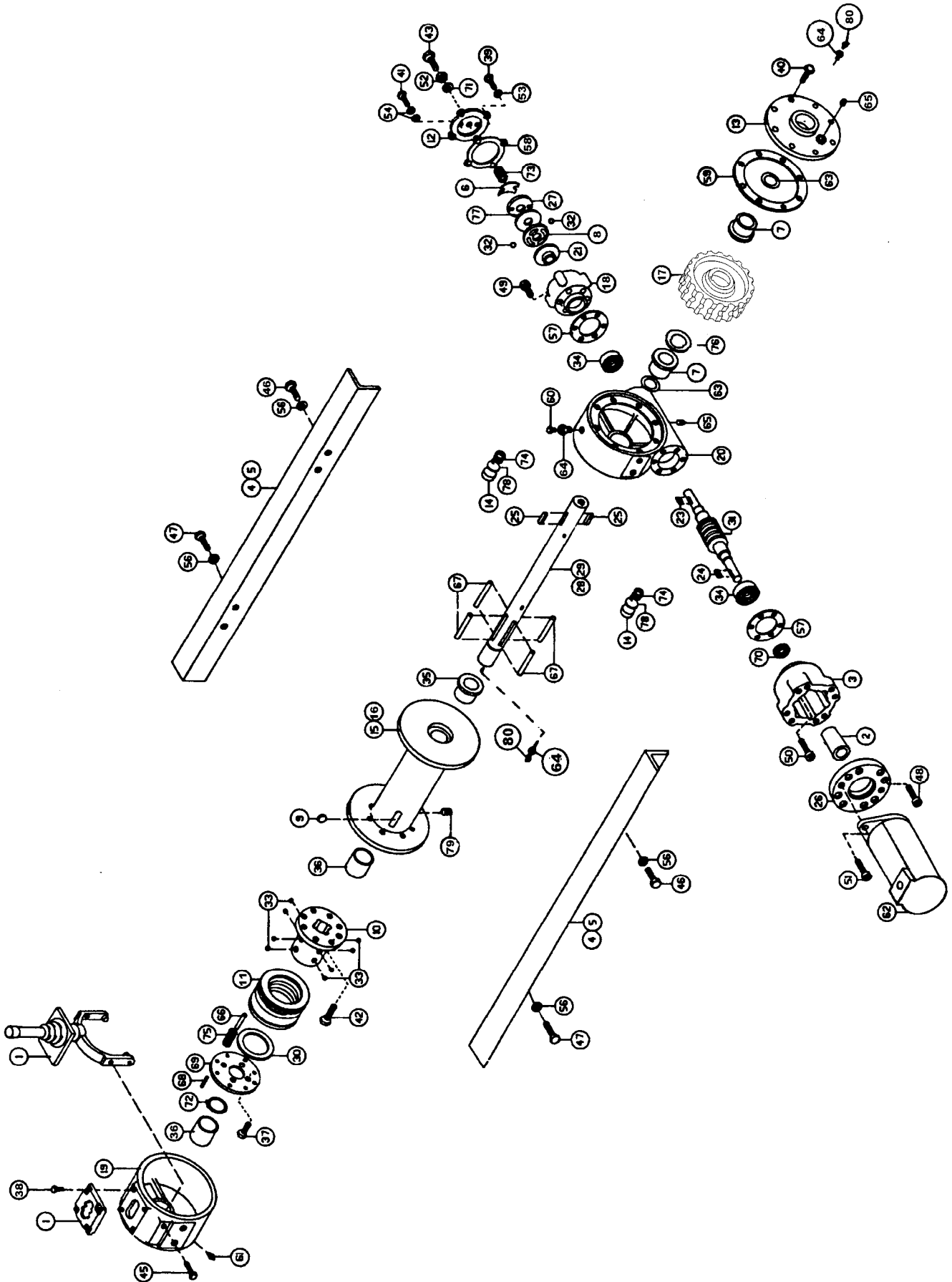

PARTS LIST MODEL H-800 DOW-LOK®

Item No.	Qty.	Parts No.	Description	Item No.	Qty.	Parts No.	Description
1	1	276033	SHIFTER ASSEMBLY	40	8	414277	CAPSCREW 3/8-16NC X 1 LG HX HD GR5 NYLOK HVY P
2	1	299733	COUPLING ASSEMBLY	41	2	414399	CAPSCREW 3/8-24NF X 1-1/4 LG ALL-THRD GR5
3	1	300048	ADAPTER	42	8	414571	CAPSCREW 1/2-20NF X 1 LG HX HD GR5
4	2	302710	ANGLE - Y800	43	1	414603	CAPSCREW 1/2-20NF X 1-3/4 LG ALL-THRD GR5
5	2	302711	ANGLE - STD.				
6	1	306035	SPRING - FLAT	45	2	414619	CAPSCREW 1/2-13NC X 2-1/2 LG HX HD ALL-THRD ZP
7	2	308083	BUSHING	46	4	414751	CAPSCREW 3/4-10NC X 1-3/4 GR5 NYLOK HVY PATCH
8	1	314007	CAM PLATE	47	4	414777	CAPSCREW 3/4-10NC X 1-3/4 GR5
9	1	314010	CABLE ANCHOR ("STD." DRUM ONLY)	48	8	414871	CAPSCREW 5/16-18NC X 1-1/4 LG SOC HD LOK-WEL
10	1	324151	CLUTCH	49	6	414897	CAPSCREW 3/8-16NC X 1 LG SOC HD
11	1	324318	LOCKING RING	50	6	414909	CAPSCREW 3/8-16NC X 1-3/4 LG SOC HD LOK-WEL
12	1	328027	COVER - BRAKE	51	2	414950	CAPSCREW 1/2-13NC X 1-3/4 LG SOC HD LOK-WEL
13	1	328122	COVER - GEAR HOUSING	52	1	418067	NUT 1/2-20NF HX JAM
14	2	330010	SHOE - DRAG BRAKE	53	4	418163	LOCKWASHER 5/16 MED SECT PLTD
15	1	332167	DRUM (STANDARD)	54	4	418184	WASHER - FLAT 3/8 ALUM
16	1	332172	DRUM ("Y" 800)	56	8	418249	LOCKWASHER 3/4 MED SECT
17	1	334188	GEAR - R.H.	57	2	442192	GASKET
18	1	338221	HOUSING - BRAKE	58	1	442194	GASKET
19	1	338235	HOUSING - CLUTCH	59	1	442195	GASKET
20	1	338242	HOUSING - GEAR	60	1	456008	FITTING - RELIEF
21	1	340011	HUB - BRAKE	61	1	456031	FITTING - LUBE
23	1	342053	KEY	62	1	458048	MOTOR - HYD
24	1	342092	KEY	63	2	462013	QUAD-RING
25	2	342153	KEY	64	3	468002	REDUCER
26	1	350535	PLATE - HYD. ADAPTER	65	2	468011	PIPE PLUG
27	1	352021	PLATE - RETAINER	66	4	470042	PIN - ROLL
28	1	357498	SHAFT - DRUM (STD.)	67	4	470044	PIN - DOWEL
29	1	357502	SHAFT - DRUM (Y800)	68	4	470056	PIN - ROLL
30	1	362224	SPACER	69	1	474030	PLATE - RETAINER
31	1	368082	WORM R.H.	70	1	486068	SEAL - OIL
32	2	400007	BALL - BRAKE	71	1	486076	THREAD SEAL
33	8	400011	BALL - CLUTCH	72	1	490025	RING - RETAINER
34	2	402045	BEARING - BALL	73	1	494010	SPRING
35	1	412051	BUSHING	74	2	494022	SPRING - DISC
36	2	412052	BUSHING	75	4	494069	SPRING
37	4	414038	CAPSCREW 1/4-20NC X 3/4 LG HX HD GR5	76	1	518016	THRUST WASHER
38	4	414069	CAPSCREW 5/16-18NC X 3/4 LG HX HD	77	1	530007	DISC - BRAKE
39	4	414111	CAPSCREW 5/16-18NC X 1 LG HX HD GR5	78	2	530094	SPACER - BRAKE
				79	1	416059	SETSCREW ("Y" DRUM ONLY)
				80	2	456039	LUBE FITTING

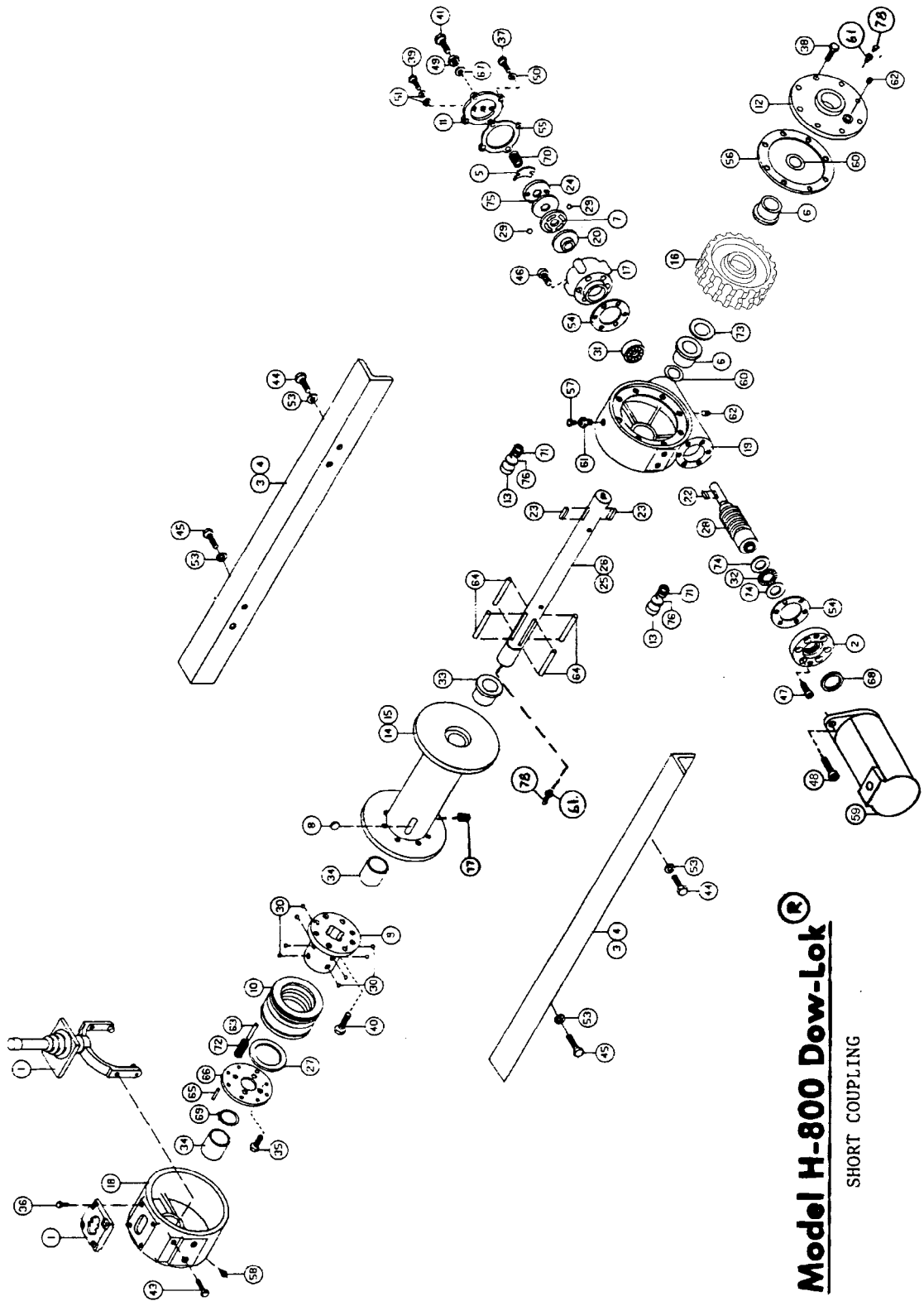

Model H-800 Dow-Lok®
SHORT COUPLING

PARTS LIST MODEL H-800SC DOW-LOK® (short coupling)

Item No.	Qty.	Part No.	Description	Item No.	Qty.	Part No.	Description
1	1	276033	SHIFTER ASSEMBLY	40	8	414571	CAPSCREW 1/2-20NF X 1 LG HX HD GR5
2	1	300063	ADAPTER	41	1	414603	CAPSCREW 1/2-20NF X 1-3/4 LG ALL-THRD GR5
3	2	302710	ANGLE - Y800				
4	2	302711	ANGLE - STD.	43	2	414619	CAPSCREW 1/2-13NC X 2-1/2 LG HX HD ALL-THRD ZP
5	1	306035	SPRING - FLAT	44	4	414751	CAPSCREW 3/4-10NC X 1-3/4 GR5 NYLOK HVY PATCH
6	2	308083	BUSHING	45	4	414777	CAPSCREW 3/4-10NC X 1-3/4 GR5
7	1	314007	CAM PLATE	46	6	414897	CAPSCREW 3/8-16NC X 1 LG SOC HD
8	1	314010	CABLE ANCHOR (STD. DRUM ONLY)	47	6	414913	CAPSCREW 3/8-16NC X 1-1/4 LG SOC HD LOK-WEL
9	1	324151	CLUTCH	48	2	414952	CAPSCREW 1/2-13NC X 1-1/2 LG SOC HD LOK-WEL
10	1	324318	LOCKING RING	49	1	418067	NUT 1/2-20NF HX JAM
11	1	328027	COVER - BRAKE	50	4	418163	LOCKWASHER 5/16 MED SECT PLTD
12	1	328122	COVER - GEAR HOUSING	51	4	418184	WASHER - FLAT 3/8 ALUM
13	2	330010	SHOE - DRAG BRAKE				
14	1	332167	DRUM (STANDARD)	53	8	418249	LOCKWASHER 3/4 MED SECT
15	1	332172	DRUM ("Y" 800)	54	2	442192	GASKET
16	1	334188	GEAR - R.H.	55	1	442194	GASKET
17	1	338221	HOUSING - BRAKE	56	1	442195	GASKET
18	1	338235	HOUSING - CLUTCH	57	1	456008	FITTING - RELIEF
19	1	338242	HOUSING - GEAR	58	1	456031	FITTING - LUBE
20	1	340011	HUB - BRAKE	59	1	458048	MOTOR - HYD
				60	2	462013	QUAD-RING
22	1	342053	KEY	61	3	468002	REDUCER
23	2	342153	KEY	62	2	468011	PIPE PLUG
24	1	352021	PLATE - RETAINER	63	4	470042	PIN - ROLL
25	1	357498	SHAFT - DRUM (STD.)	64	4	470044	PIN - DOWEL
26	1	357502	SHAFT - DRUM (Y800)	65	4	470056	PIN - ROLL
27	1	362224	SPACER	66	1	474030	PLATE - RETAINER
28	1	368196	WORM R.H.	67	1	486076	THREAD SEAL
29	2	400007	BALL - BRAKE	68	1	486079	SEAL - PILOT
30	8	400011	BALL - CLUTCH	69	1	490025	RING - RETAINER
31	1	402045	BEARING - BALL	70	2	494010	SPRING
32	1	402109	BEARING - THRUST	71	2	494022	SPRING - DISC
33	1	412051	BUSHING	72	4	494069	SPRING
34	2	412052	BUSHING	73	1	518016	THRUST WASHER
35	4	414038	CAPSCREW 1/4-20NC X 3/4 LG HX HD GR5	74	2	518036	THRUST WASHER
36	4	414069	CAPSCREW 5/16-18NC X 3/4 LG HX HD	75	1	530007	DISC - BRAKE
37	4	414111	CAPSCREW 5/16-18NC X 1 LG HX HD GR5	76	2	530094	SPACER - BRAKE
38	8	414277	CAPSCREW 3/8-16NC X 1 LG HX HD GR5 N HVY P	77	1	416059	SETScrew ("Y" DRUM ONLY)
39	2	414571	CAPSCREW 3/8-24NF X 1-1/4 LG ALL-THRD GR5	78	2	456039	LUBE FITTING

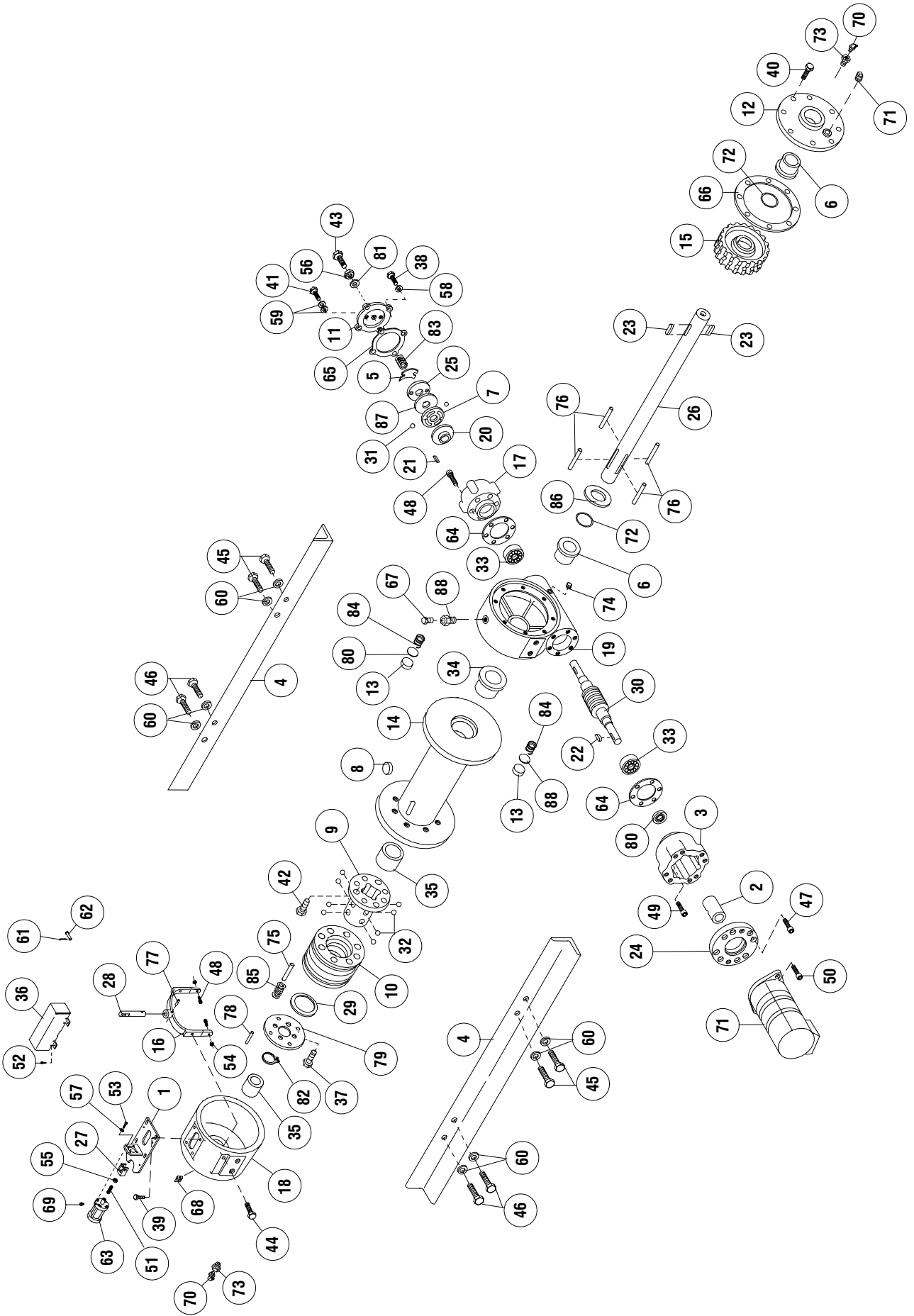

PARTS LIST MODEL H-800 DOW-LOK® WITH AIR SHIFTER

Item No.	Qty.	Part No.	Description	Item No.	Qty.	Part No.	Description
1	1	299695	AIR SHIFTER BRACKET ASSEMBLY	43	1	414603	CAPSCREW 1/2-20NF X 1-3/4 LG ALL-THRD GR5
2	1	299733	COUPLING ASSEMBLY	44	2	414619	CAPSCREW 1/2-13NC X 2-1/2 LG HX HD ALL-THRD ZP
3	1	300048	ADAPTER	45	4	414751	CAPSCREW 3/4-10NC X 1-3/4 GR5 NYLOK HVY PATCH
4	2	302710	ANGLE - "Y" DRUM	46	4	414777	CAPSCREW 3/4-10NC X 1-3/4 GR5
5	2	302711	ANGLE - STD.	47	8	414871	CAPSCREW 5/16-18NC X 1-1/4 LG SOC HD LOK-WEL
6	2	306035	SPRING - FLAT	48	8	414897	CAPSCREW 3/8-16NC X 1 LG SOC HD
7	1	308083	BUSHING	49	6	414909	CAPSCREW 3/8-16NC X 1-3/4 LG SOC HD LOK-WEL
8	1	314007	CAM PLATE	50	2	414950	CAPSCREW 1/2-13NC X 1-3/4 LG SOC HD LOK-WEL
9	1	314010	CABLE ANCHOR (STD.) DRUM ONLY)	51	1	416061	SETSCREW 3/8-24NF X 1-1/4 LG
10	1	416059	SETSCREW ("Y" DRUM ONLY)	52	4	416214	SCREW #10-32NF X 1/4 LG RD HD Z/P
11	1	324151	CLUTCH	53	4	416262	SCREW #10-32NF X 3/4 LG HX SOC Z/P
12	1	324318	LOCKING RING	54	2	418035	NUT 3/8-16NC HX REG Z/P
13	1	328027	COVER - BRAKE	55	1	418041	NUT 3/8-24NF HX JAM
14	1	328122	COVER - GEAR HOUSING	56	1	418067	NUT 1/2-20NF HX JAM
15	2	330010	SHOE - DRAG BRAKE	57	4	418141	LOCKWASHER #10 MED SECT Z/P
16	1	332167	DRUM (STANDARD)	58	4	418163	LOCKWASHER 5/16 MED SECT PLTD
17	1	332172	DRUM ("Y")	59	4	418184	WASHER - FLAT 3/8 ALLUM
18	1	334188	GEAR - R.H.	60	8	418249	LOCKWASHER 3/4 MED SECT
19	1	370047	YOKE	61	1	424005	COTTER PIN
20	1	338221	HOUSING - BRAKE	62	1	424029	CLEVIS PIN
21	1	338235	HOUSING - CLUTCH	63	1	433016	AIR CYLINDER
22	1	338242	HOUSING - GEAR	64	2	442192	GASKET
23	1	340011	HUB - BRAKE	65	1	442194	GASKET
24	1	342053	KEY	66	1	442195	GASKET
25	2	342092	KEY	67	1	456008	FITTING - RELIEF
26	1	342153	KEY	68	1	456031	FITTING - LUBE
27	1	350535	PLATE - HYD. ADAPTER	69	1	456038	BREATHER VENT
28	1	352021	PLATE - RETAINER	70	2	456039	LUBE FITTING
29	1	357498	SHAFT - DRUM (STD.)	71	1	458048	MOTOR - HYD
30	1	357502	SHAFT - DRUM ("Y")	72	2	462013	QUAD-RING
31	1	358067	CLEVIS	73	3	468002	REDUCER
32	1	358069	SHIFTER SHAFT	74	2	468011	PIPE PLUG
33	1	362224	SPACER	75	4	470042	PIN - ROLL
34	1	368082	WORM R.H.	76	4	470044	PIN - DOWEL
35	2	400007	BALL - BRAKE	77	1	470045	PIN - ROLL
36	8	400011	BALL - CLUTCH	78	4	470056	PIN - ROLL
37	2	402045	BEARING - BALL	79	1	474030	PLATE - RETAINER
38	1	412051	BUSHING	80	1	486068	SEAL - OIL
39	2	412052	BUSHING	81	1	486076	THREAD SEAL
40	1	413074	COVER - AIR SHIFT	82	1	490025	RING - RETAINER
41	4	414038	CAPSCREW 1/4-20NC X 3/4 LG HX HD GR5	83	1	494010	SPRING
42	4	414111	CAPSCREW 5/16-18NC X 1 LG HX HD GR5	84	2	494022	SPRING - DISC
43	4	414126	CAPSCREW 5/16-18NC X 3/4 LG HX HD	85	4	494069	SPRING
44	8	414277	CAPSCREW 3/8-16NC X 1 LG HX HD GR5 NYLOK HVY P	86	1	518016	THRUST WASHER
45	2	414399	CAPSCREW 3/8-24NF X 1-1/4 LG ALL-THRD GR5	87	1	530007	DISC - BRAKE
46	8	414571	CAPSCREW 1/2-20NF X 1 LG HX HD GR5	88	2	530094	SPACER - BRAKE

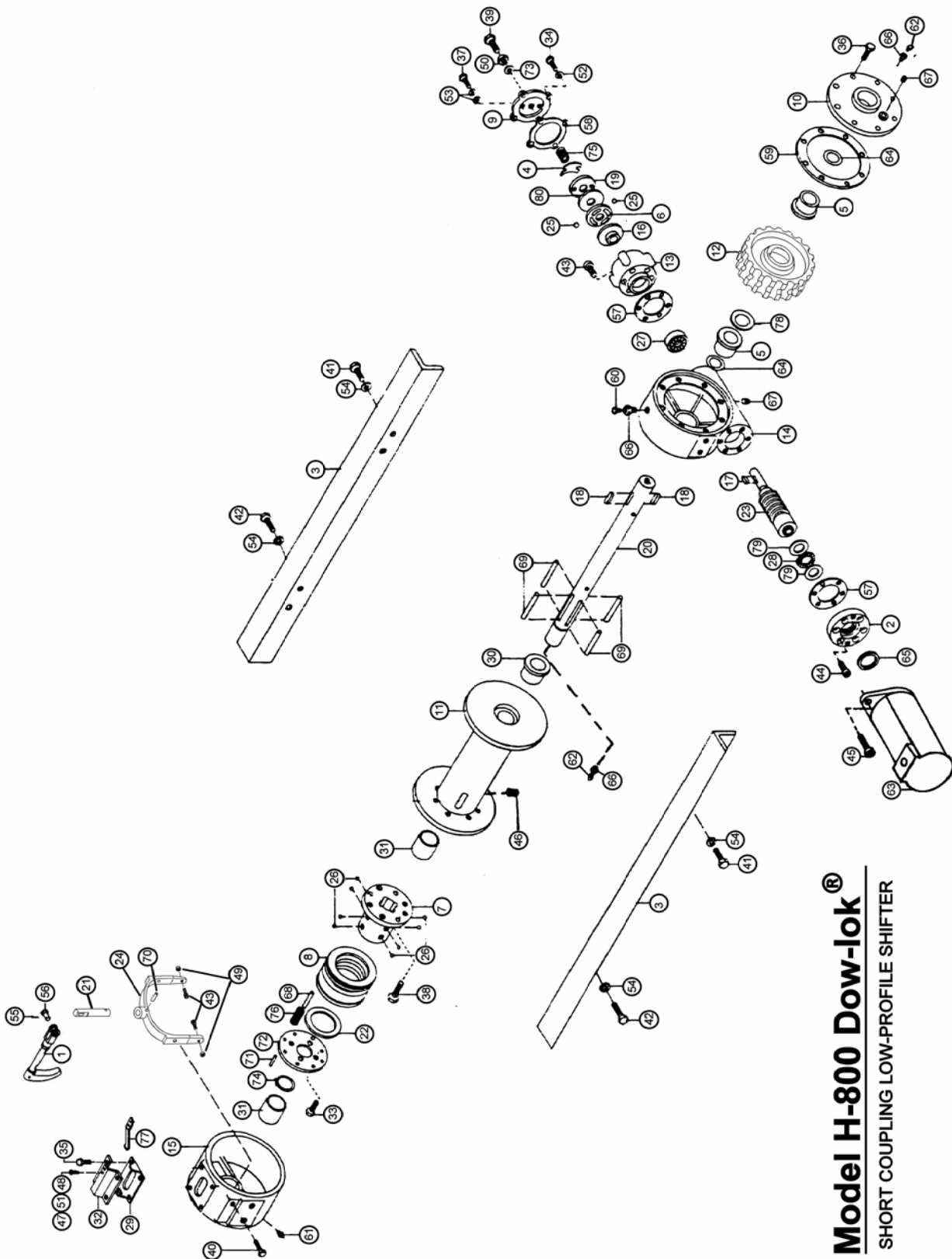

Model H-800 Dow-lok®
 SHORT COUPLING LOW-PROFILE SHIFTER

PARTS LIST MODEL H800 DOW-LOK® SHORT COUPLING & LOW-PROFILE SHIFTER

Item No.	Qty.	Part No.	Description	Item No.	Qty.	Part No.	Description
1	1	276061	SHIFTER LEVER ASSEMBLY	41	4	414751	CAPSCREW-3/4-10NC X 1.75 HEXHEAD, G-5, NYLOK
2	1	300063	ADAPTER	42	4	414777	CAPSCREW-3/4-10NC X 1 3/4 HEXHEAD, GR-5
3	2	302093	ANGLE	43	8	414897	CAPSCREW-3/8-16NC X 1 SOCKET HEAD
4	1	306035	SPRING-FLAT	44	6	414913	CAPSCREW-3/8-16NC X 1-1/4 SOCKET HEAD
5	2	308083	BUSHING	45	2	414952	CAPSCREW-1/2-13NC X 1 1/2 SOCKET HEAD, ZINC
6	1	314007	CAM PLATE	46	1	416059	SETSCREW 3/8-16NC X 1/2
7	1	324151	CLUTCH	47	2	416236	SCREW-#10-24NC X 1/2 SLOT HEXHEAD, ZINC
8	1	324318	LOCKING RING	48	2	418004	NUT-#10-24NC REG., ZINC
9	1	328027	COVER-BRAKE	49	2	418035	NUT-3/8-16NC REG., ZINC
10	1	328122	COVER-GEAR HOUSING	50	1	418067	NUT-1/2-20NF JAM
11	1	332172	DRUM-CABLE	51	2	418141	LOCKWASHER-#10 MED SECTION, ZINC
12	1	334188	GEAR, WORM - R.H.	52	4	418163	LOCKWASHER-5/16 MED SECT, ZINC
13	1	338221	HOUSING-BRAKE	53	4	418184	WASHER-FLAT 3/8
14	1	338242	HOUSING-GEAR	54	8	418249	LOCKWASHER-3/4 ID MED SECT,ZINC
15	1	338371	HOUSING-CLUTCH	55	1	424005	COTTER PIN
16	1	340011	HUB-BRAKE	56	1	424205	CLEVIS PIN
17	1	342053	KEY	57	2	442192	GASKET
18	2	342153	KEY	58	1	442194	GASKET
19	1	352021	RETAINER PLATE	59	1	442195	GASKET
20	1	357502	SHAFT-OUTPUT	60	1	456008	RELIEF FITTING
21	1	358075	SHAFT-SHIFTER	61	2	456031	LUBE FITTING
22	1	362224	SPACER	62	2	456039	LUBE FITTING
23	1	368196	WORM-R.H.	63	1	458048	MOTOR
24	1	370047	YOKE-SHIFTER	64	2	462013	QUAD-RING
25	2	400007	BALL BRAKE	65	1	486079	PILOT SEAL
26	8	400011	BALL CLUTCH	66	3	468002	REDUCER
27	1	402045	BEARING-BALL	67	2	468011	PIPE PLUG
28	1	402109	BEARING-THRUST	68	4	470042	ROLL PIN
29	1	408112	BRACKET CLUTCH SHIFTER	69	4	470044	DOWEL PIN
30	1	412051	BUSHING-GEAR HOUSING	70	1	470045	ROLL PIN
31	2	412052	BUSHING-END BEARING	71	4	470056	ROLL PIN
32	1	413028	COVER-CLUTCH SHIFTER	72	1	474030	RETAINER PLATE
33	4	414038	CAPSCREW-1/4-20NC X 3/4 HEXHEAD, GR-5, ZINC	73	1	486076	SEAL
34	4	414111	CAPSCREW-5/16-18NC X 1 HEXHEAD, GR-5	74	1	490025	SNAP RING
35	4	414142	CAPSCREW-5/16-18NC X 3/4 HEXHEAD GR-5	75	1	494010	SPRING
36	8	414277	CAPSCREW-3/8-16NC X 1 HEXHEAD, GR-5, NYLOK	76	4	494069	SPRING
37	2	414399	CAPSCREW-3/8-24NF X 1.25, HX,GR-5, ALL-THREAD	77	1	494078	SPRING-RETAINER
38	8	414571	CAPSCREW-1/2-20NF X 1 HEXHEAD GR-5	78	1	518016	THRUST WASHER
39	1	414603	CAPSCREW-1/2-20NF X 1 3/4 ALL-THREAD, GR-5	79	2	518036	THRUST WASHER
40	2	414619	CAPSCREW-1/2-13NC X 2.5, HEXHEAD, ALL-THREAD, GR-5	80	1	530007	DISC-BRAKE

Warranty Information

Ramsey Winches are designed and built to exacting specifications. Care and skill go into every winch we make. If the need should arise, warranty procedure is outlined on the back of your self-addressed, postage paid warranty card. Please read and fill out the enclosed warranty card and send it to Ramsey Winch Company. If you have any problems with your winch, please follow instructions for prompt service on all warranty claims.

Limited Lifetime Warranty

RAMSEY WINCH warrants each new RAMSEY Winch to be free from defects in material and workmanship for a period of one (1) year from date of purchase.

The obligation under this warranty, statutory or otherwise, is limited to the replacement or repair at the Manufacturer's factory, or at a point designated by the Manufacturer, of such part that shall appear to the Manufacturer, upon inspection of such part, to have been defective in material or workmanship.

This warranty does not obligate RAMSEY WINCH to bear the cost of labor or transportation charges in connection with the replacement or repair of defective parts, nor shall it apply to a product upon which repair or alterations have been made, unless authorized by Manufacturer, or for equipment misused, neglected or which has not been installed correctly.

RAMSEY WINCH shall in no event be liable for special or consequential damages. RAMSEY WINCH makes no warranty in respect to accessories such as being subject to the warranties of their respective manufacturers.

RAMSEY WINCH, whose policy is one of continuous improvement, reserves the right to improve its products through changes in design or materials as it may deem desirable without being obligated to incorporate such changes in products of prior manufacture.

If field service at the request of the Buyer is rendered and the fault is found not to be with RAMSEY WINCH's product, the Buyer shall pay the time and expense to the field representative. Bills for service, labor or other expenses that have been incurred by the Buyer without approval or authorization by RAMSEY WINCH will not be accepted

See warranty card for details.



RAMSEY WINCH COMPANY

P.O. BOX 581510 • Tulsa, OK 74158-1510 • <http://www.ramsey.com>

Telephone: (918) 438-2760 • FAX: (918) 438-6688