

**Seoul Office :**

Doosan Tower 27th FL. 18-12, Euljiro-6 Ga,
Jung-Gu, Seoul, Korea 100-730

Tel : +82-2-3398-8049

Fax : +82-2-3398-8117

www.doosaninfracore.com

Doosan Infracore Europe S.A.

1A, Rue Achille Degrace, 7080 Frameries, Belgium
Tel : +32-65-61-3230 Fax : +32-65-67-7338

Doosan Infracore U.K., Ltd.

Doosan House, Unit 6, 3 Heol Y Gamlas, Parc Nantgarw, Nantgarw,
Cardiff. CF15 7QU, U.K.
Tel : +44-1443-84-2273 Fax : +44-1443-84-1933

Doosan Infracore Europe S.A. Gernay

Heinrich-von- Stephan str. 2 40764 Langenfeld, Germany
Tel : +49-2173-2035-210 Fax : +49-2173-2035-219

Doosan Infracore France

ZAC de La Clef Saint Pierre - Buroplus 2 1A Avenue Jean d'Alembert
78990 Elancourt, France
Tel : +33-(0)1-30-16-21-41 Fax : +33-(0)1-30-16-21-44

Doosan Infracore America Corporation

2905 Shawnee Industrial Way, Suwanee, Georgia 30024, U. S. A
Tel : +1-770-831-2200 Fax : +1-770-831-0480

Doosan Infracore China Co., Ltd.

#28, Wuzhishan Road, Eco. & Tech, Development Zone,
Yantai, Shandong, China
Tel : +86-535-638-2000 Fax : +86-535-638-2004

Doosan Infracore South Africa (PTY) LTD.

60C Electron Road, Isando 1600, Johannesburg, South Africa
Tel : 27-11-974-2095 Fax : 27-11-974-2778

Doosan Infracore Middle East Center (Dubai)

P.O.Box 183127, Al-Serkal Building, Air Port Road, Dubai, U.A.E
Tel : +971-4-295-2781~2 Fax : +971-4-295-2783

Doosan Infracore do Brasil Serviços de Suporte Comercial Ltda.

Alameda Santos 2222 Cj52 CEP 01418.200 São Paulo ,SP, Brasi
Tel : +55-11-9533-0219 Fax :

Doosan Infracore India Liaison Office

402, A-wing, Business Square, Andheri-Kurla Road, Andheri(East),
Mumbai - 400093
Tel : +91-22-4030-6501 Fax : +91-22-4030-6599



PBP D27Z30Z0 0711

The illustrations do not necessary show the product in standard version.
All products and equipment are not available in all markets.
Materials and specifications are subject to change without prior notice.



Doosan Infracore
Construction Equipment

Compact Equipment

Mini Excavators DX27Z • DX30Z



Photo may include optional equipment



Doosan DX27Z, DX30Z Hydraulic Excavator :
A New Model with Novel Features

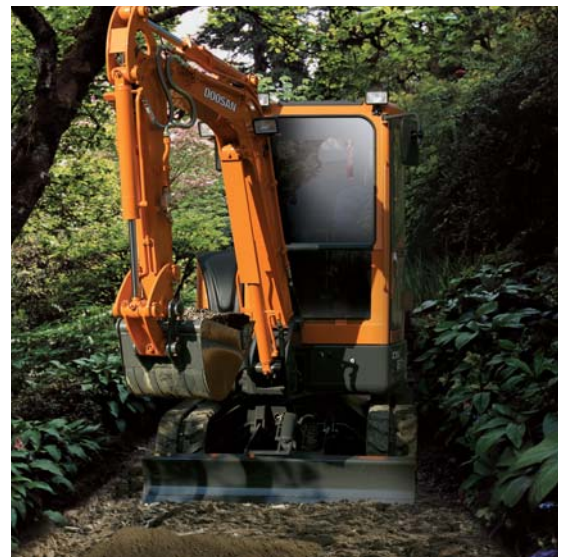

DX 27z



DX 30z

Maximizing the merits of the previous series, the DX27Z and DX30Z are focused on the fundamentals of zero tail equipment. The cabin structure is designed to provide the operator with excellent comfort and all round visibility, whilst maintaining the minimum working radius.



Based on the fundamentals of such zero tail swing excavators;

- **Comfort** - A wide comfortable cabin is provided allowing the operator to work with all round visibility in a safe working environment.
- **Performance** - Excellent working performances and the highest work efficiency are achieved as a result of the new generation engine and an advanced hydraulic system.
- **Reliability** - Enhanced structural reliability has been achieved through stress test analysis, helping to extend the life of the equipment and reduce maintenance costs.
- **Maintenance** - Large opening covers ensure easy access for daily checks and conveniently located service parts help to reduce servicing times.

Comfort

DX27Z/DX30Z

As powerful, elaborate and small excavator, DX27Z and DX30Z provides greater space to ensure the optimal work environment for the operator. The ergonomically designed seat and arm rest as well as the wide space minimizes the fatigue of operator. The position of the control stand and joystick together with the monitor by which all information can be checked at a glance, further provides for a more convenient work environment. It's your turn to operate this compact excavator designed by DOOSAN specifically with the operator in mind.



Comfortable Operating Cabin

A roomy, minimal shock and low noise operator's cab with safety glass windows on all four all-round visibility. The front screen slides up in to the roof and the right hand side window can be opened for ventilation.



Cabin type ↑



Canopy type →





Control Stand

The left and right control stands are ergonomically placed for convenient operation. The control stand surfaces have ample room to install several option switches. The uni-body plastic design provides the operator with a spacious and comfortable cabin environment.



Monitor

The centralized display panel provides comprehensive information about the status of the machine in an easy to read format. The high quality display panel is waterproof and all information can be seen at a glance.



Joystick

The hydraulic joystick levers have very comfortable grips that allow the operator to perform precise operations very easily.

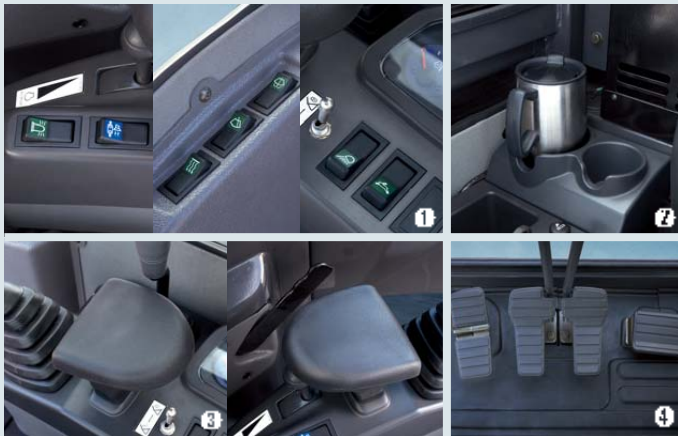

1 Switch

The ergonomically placed switches maximizes convenience for the operator.

2 Cup Holder

The conveniently located cup holders add to the comfort of the cabin.

3 Arm Rest

The arm rests provide operator comfort during long working days. These have been relocated to the control stand giving more comfort as opposed to arm rests on the seat.

4 Floor Plate (Rubber mat)

The breaker pedal (left) and boom swing pedal (right) are installed in a very spacious and convenient location. In addition, the rubber floor mats contribute to a very comfortable environment. The door opening has been increased by removing the lower lip which allows easy cleaning of the interior.



Defroster

The high capacity defroster is installed on the right windows and provides excellent performance in cold conditions. Eliminating both frost and moisture very efficiently, to provide a safer working condition for the operator. (Cabin Type Only)



Comfortable Sliding Seat



Control Stand Tilt Function

Performance

DX27Z/DX30Z

The highest performance is guaranteed in any working condition. The advanced hydraulic system combined with a powerful engine provides for powerful excavation and work efficiency as well as the biggest break out and tractive forces.

As a result the DX27Z, DX30Z provides outstanding performance, work efficiency and the ability to adapt to any work environment.



Boom swing

The convenient boom swing function gives the capability to work in very narrow areas. The newly designed swing bracket and the increased boom swing cylinder size ensures powerful and stable boom swing performance.

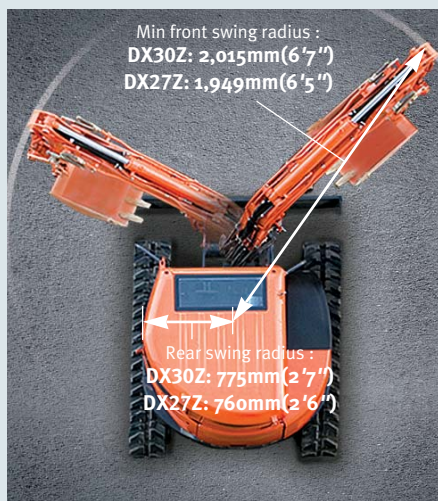



3TNV82A Engine

The DX27Z, DX30Z have a powerful and eco-friendly engine, that always provides high operating efficiency and please working conditions.



E/G Control Lever

The engine control lever is placed in a very convenient location easily accessible by the operator to easily control the engine speed.



Dozer Blade

Welded, unitized blade provides durability even under harsh working conditions.

DX27Z: 1,520mm x 277mm (5' x 11")
 1,570mm x 277mm (5'2" x 11")
 DX30Z: 1,550mm x 310mm (5'1" x 1')



DX27Z

Powerful Digging Force (Bucket)

Powerful, efficient digging with increased digging force. Bucket Digging force : (ISO/SAE) DX27Z: 2,220 kgf / 2,020 kgf
 DX30Z: 2,800 kgf / 2,480 kgf

Maintenance & Reliability

DX27Z/DX30Z

Since DX27Z and DX30Z are designed so that all parts can be checked at a glance, the radiator, battery and diverse filters can be easily inspected, ensuring easier service and check-up.

Furthermore, the X chassis and D-type frame ensure exceptional durability and minimize deformation caused by impact. DX27Z and DX30Z will guarantee productivity due to exceptional durability and convenient maintenance.

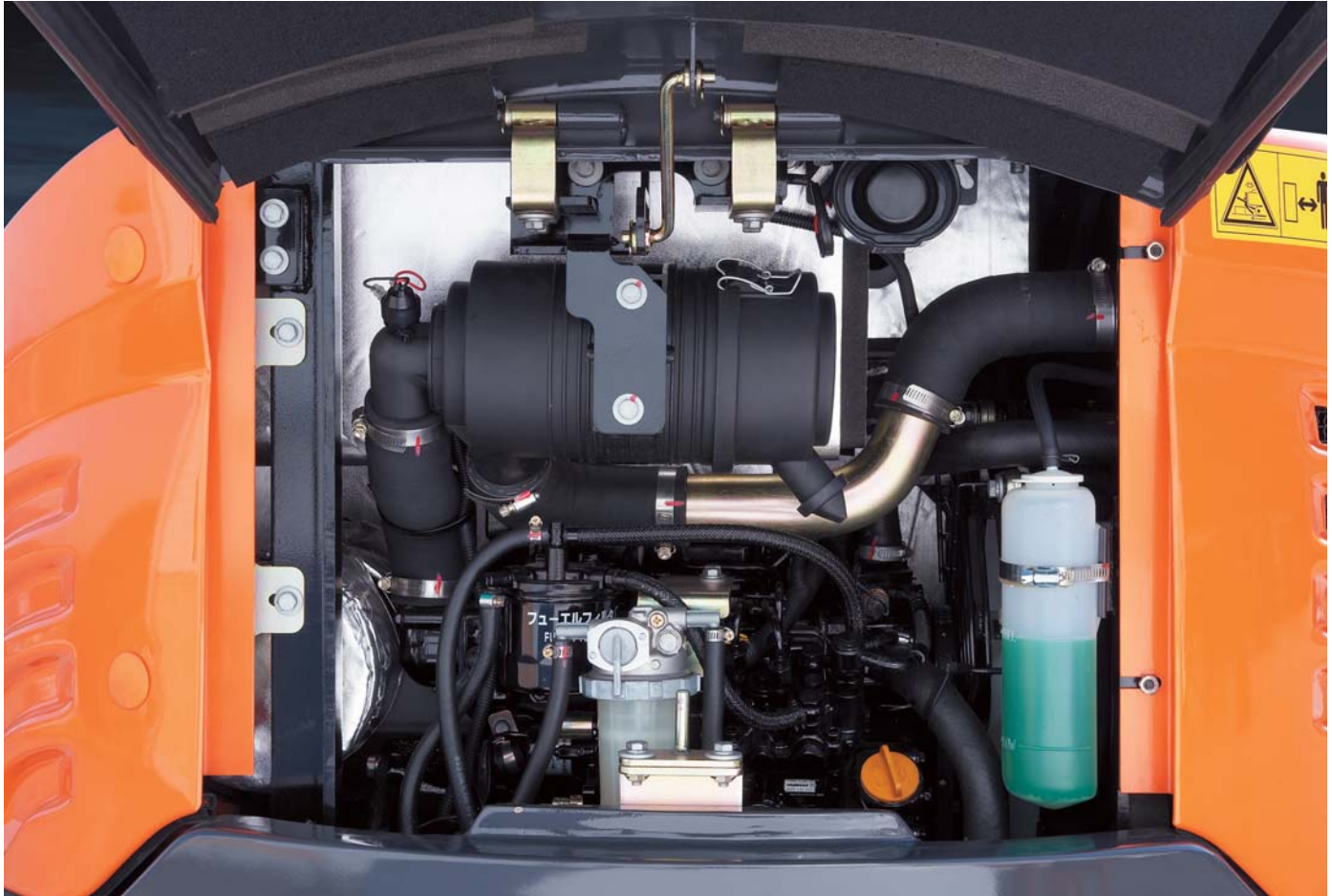

Engine Room

The engine compartment is designed for easier service and the sturdy sound proofing inside the engine cover reduces the noise to provide a more friendly environment for the operator and those around it.



Easy maintenance

Access to the various radiators is very simple, making cleaning more convenient. The battery and washer fluid level can also be easily checked.

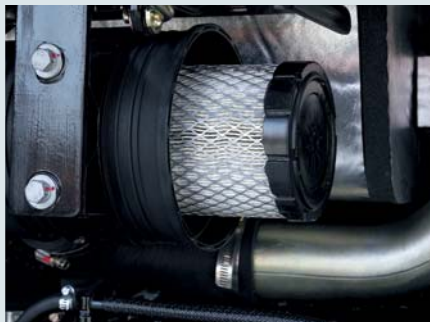

Air cleaner

The large capacity forced air cleaner removes over 99% of airborne particles, reducing the risk of engine contamination, and increasing the cleaning and cartridge change intervals greater.



Air Breather

The hydraulic system was designed to prevent the pump from cavitation.

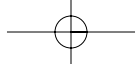

DX30Z

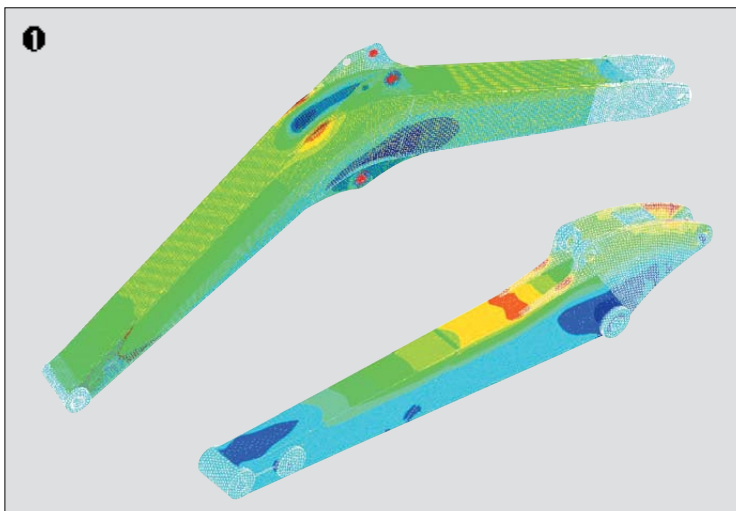

Strengthened Boom

The shape of the boom has been optimally designed using finite elements and 3-dimensional computer simulation, allowing the loads to be better distributed throughout the structure. This combined with increased material thickness means improved durability and reliability by limiting element fatigue.

Arm Assembly

In the arm assembly greater strength is gained by using cast elements and reinforcement around the bosses to increase the overall life of the component.

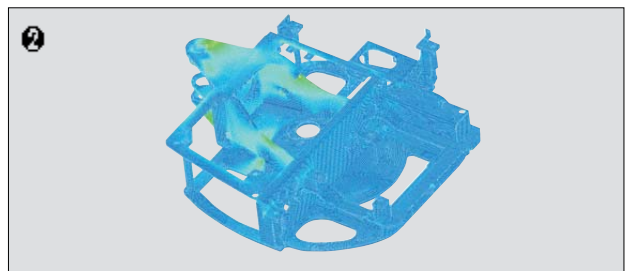

D-type Frame

The D-type frame and chassis frame add strength and minimize distortion due to shocks.

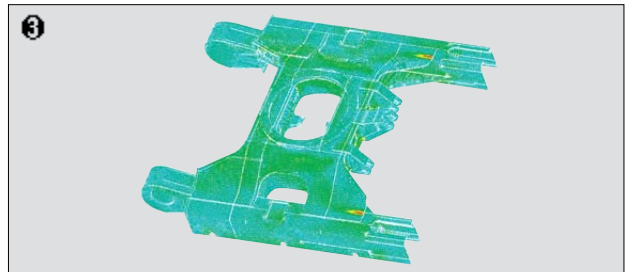

X-chassis

The X-chassis frame section has been designed using finite element and 3-dimensional computer simulation, to ensure greater durability and optimum structural integrity. The swing gear is solid and stable.



Rubber tracks

The rubber shoes not only offers greater non-slip and grip capabilities but are less harmful to pathways and road surfaces in urban environments than conventional steel shoes.



Bucket

Hardened bucket teeth provide durability and can be easily unbolted for removal, straightening or replacing.



Oil Gauge

Hydraulic oil level can be easily checked through the gauge on the side of the hydraulic tank.



Grease Piping

Integrated grease piping is designed for easy maintenance of the swing bearing and swing cylinder.



DX27Z/DX30Z

Technical specifications

ENGINE

Model	DX27Z	YANMAR, 3TNV82A-SDB
	DX30Z	YANMAR, 3TNV82A-PDB
Number of cylinders		3
Nominal flywheel power	DX27Z	15.8 kW(21.2HP) @ 2,200 rpm (SAE J 1349, net)
	DX30Z	18.1 kW(24.3HP) @ 2,400 rpm (SAE J 1349, net)
Max torque	DX27Z	8.97 kgf.m / 1,000 rpm
	DX30Z	8.97 kgf.m / 1,200 rpm
Piston displacement		1,331 cc (81.217 cu.in)
Bore & stroke		∅82 mm x 84 mm (3.2" X 3.3")
Starter		12 V x 1.7 kW
Batteries		1 x 12 V / 80 Ah
Alternator		12 V / 40 A

HYDRAULIC CYLINDERS

The piston rods and cylinder bodies are made of high-strength steel. A shock absorbing mechanism is fitted in all cylinders to ensure shock-free operation and extend piston life.

DX27Z

Cylinders	Quantity	Bore X Rod diameter X stroke
Boom	1	70 X 40 X 567mm(2.8" X 1.6" X 1'10")
Arm	1	70 X 40 X 500mm(2.8" X 1.6" X 1'8")
Bucket	1	65 X 35 X 435mm(2.6" X 1.4" X 1'5")

DX30Z

Cylinders	Quantity	Bore X Rod diameter X stroke
Boom	1	80 X 45 X 573mm(3.1" X 1.8" X 1'11")
Arm	1	75 X 45 X 598mm(3" X 1.8" X 2')
Bucket	1	70 X 45 X 515mm(2.8" X 1.8" X 1'8")

CONTROL.2 IMPLEMENT LEVERS

Pilot pressure control type. Right lever is boom and bucket control, left lever for swing and arm control.

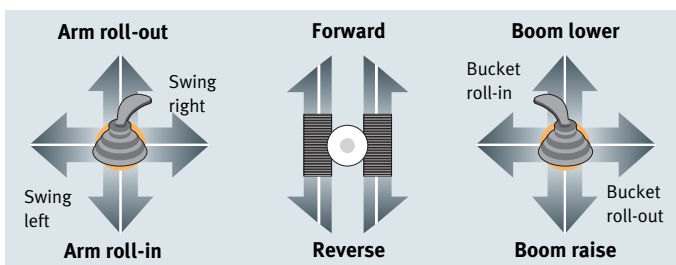

HYDRAULIC SYSTEM

2 Variable displacement axial piston tandem type pumps.
2 Gear pumps and control valve (9-spool) of section block construction. This original design enables both independent and combined operations of all function, joystick control type levers.

DX27Z

Main pumps	2 variable displacement axial piston pumps max flow: 2 x 26.4 \bar{Q} /min + 18.9 \bar{Q} /min (2 X 6.97 US gpm + 5 US gpm, 2 X 5.81 lmp gpm + 4.2 lmp gpm)
Pilot pump	Gear pump - max flow: 11.2 \bar{Q} /min (3 US gpm, 2.5 lmp gpm)
Maximum system pressure	Boom/Arm/Bucket: 220 kgf/cm ² (215bar) Travel: 220 kgf/cm ² (215bar) Swing: 220 kgf/cm ² (215bar)

DX30Z

Main pumps	2 variable displacement axial piston pumps max flow: 2 x 37.2 \bar{Q} /min + 20.4 \bar{Q} /min (2 X 9.83 US gpm + 5.4 US gpm, 2 X 8.18 lmp gpm + 4.5 lmp gpm)
Pilot pump	Gear pump - max flow: 10.8 \bar{Q} /min (2.9 US gpm, 2.4 lmp gpm)
Maximum system pressure	Boom/Arm/Bucket: 210 kgf/cm ² (205 bar) Travel: 210 kgf/cm ² (205 bar) Swing: 200 kgf/cm ² (196 bar)

SWING MECHANISM

High-torque, axial piston motor with planetary reduction gear bathed in oil. Swing bearing is single-row, shear type ball bearing with induction-hardened internal gear. Internal gear and pinion gear immersed in lubricant. A swing lock secures the upper structure for transportation.

DX27Z

Swing speed	9.63 rpm
Rear swing radius	760mm(2'6") 835mm(2'9") - with Additional Weight

DX30Z

Swing speed	9.7 rpm
Rear swing radius	775mm(2'7") 850mm(2'9") - with Additional Weight

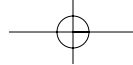

UNDERCARRIAGE

Tractor type undercarriage. Heavy duty track frame, all welded stress-relieved structure. Top grade materials are used for toughness. Side frames are welded, securely and rigidly to the track frame. Lifetime-lubricated track rollers, idlers and sprockets with floating seals. Hydraulic track adjusters with shock-absorbing recoil springs.

Number of rollers and track shoes per side

	DX27Z	DX30Z
Lower rollers	3	4
Track shoes	Rubber shoe	Rubber shoe
Overall track length	1,970 mm (6'6")	2,100 mm (6'11")
Shoe width	300mm(1')	300mm(1')

ENVIRONMENT

A roomy, shock independent and low noise operator's cab, four-side safety glass windows gives excellent all-round visibility. the front window slides up and stores in the roof and the right side window can be opened for ventilation. Fully adjustable suspension seat. ISO standard cab.

LwA External noise	
Guaranteed Sound Power Level	93dB(A)(2000/14/EC)
LpA Operator noise	79dB (A) (ISO 6396)

WEIGHT

DX27Z

Boom 2,000 mm (6'7")/ Bucket SAE 0.08 m³ (0.11 yd³)/ Shoe 300m (1')

Arm Length	Operating Weight	Ground Pressure
1,100 mm (3'7")	2,790 kg (6,150 lb)	0.27kgf/cm ² (25 kpa, 3.7 psi)
1,300 mm (4'3")	*2898.5 kg (6,390 lb)	*0.28kgf/cm ² (27 kpa, 3.9 psi)

* with Additional Weight

DX30Z

Boom 2,280 mm (7'6")/ Bucket SAE 0.091 m³ (0.12 yd³)/ Shoe 300m (1')

Arm Length	Operating Weight	Ground Pressure
1,190 mm (3'11")	3,180 kg (7,011 lb)	0.294kgf/cm ² (29 kpa, 4.2 psi)
1,300 mm (4'3")	*3,284 kg (7,240 lb)	*0.305kgf/cm ² (30 kpa, 4.3psi)

* with Additional Weight

BUCKET

DX27Z

Capacity		Width		Weight	Recommendation	
PCSA, heaped	CECE heaped	Without side cutters	With side cutters		2,000mm (6'7") Boom	
					1,100mm (3'7")Arm	1,300mm (4'3")Arm
0.08m ³ (0.11yd ³)	0.07m ³ (0.09yd ³)	448mm (1'6")	474mm (1'7")	58 kg (127.8 lb)	B	C

DX30Z

Capacity		Width		Weight	Recommendation	
PCSA, heaped	CECE heaped	Without side cutters	With side cutters		2,280mm (7'6") Boom	
					1,190mm (3'11")Arm	1,300mm (4'3")Arm
0.091m ³ (0.12yd ³)	0.078m ³ (0.10yd ³)	480mm (1'7")	506mm (1'8")	71.8 kg (158.3 lb)	B	C

A. Suitable for materials with density of 2,000 kg/m³ (3,370 lb/CU · yd) or less

B. Suitable for materials with density of 1,600 kg/m³ (2,700 lb/CU · yd) or less

C. Suitable for materials with density of 1,100 kg/m³ (1,850 lb/CU · yd) or less

DRIVE

Each track is driven by an independent, high-torque, axial piston motor through planetary reduction gears. Two levers control provide smooth travel or counter-rotation upon demand.

DX27Z

Travel speed (fast/slow)	4.3/2.4 km/h (2.8 /1.5 mph)
Maximum traction force	2,400 kgf (5,291 lbf)
Maximum grade	30° / 58%

DX30Z

Travel speed (fast/slow)	4.6/2.6 km/h (2.9 /1.6 mph)
Maximum traction force	2,700 kgf (5,940 lbf)
Maximum grade	30° / 58%

REFILL CAPACITIES

DX27Z

Fuel tank	30 ♂ (7.93 US gal, 6.60 Imp gal)
Cooling system (Radiator capacity)	3.5 ♂ (0.93 US gal, 0.77 Imp gal)
Engine oil	5.5 ♂ (1.45 US gal, 1.21 Imp gal)
Final drive (each)	0.5 ♂ (0.13 US gal, 0.1 Imp gal)
Hydraulic system	45 ♂ (11.8 US gal, 9.9 Imp gal)
Hydraulic tank	30 ♂ (7.9 US gal, 6.6 Imp gal)

DX30Z

Fuel tank	35 ♂ (9.2 US gal, 7.70 Imp gal)
Cooling system (Radiator capacity)	3.5 ♂ (0.93 US gal, 0.77 Imp gal)
Engine oil	5.5 ♂ (1.45 US gal, 1.21 Imp gal)
Final drive (each)	0.5 ♂ (0.13 US gal, 0.11 Imp gal)
Hydraulic system	50 ♂ (13.21 US gal, 10.99 Imp gal)
Hydraulic tank	35 ♂ (9.25 US gal, 7.70 Imp gal)



DX27Z

Dimensions & Working ranges

DIMENSIONS

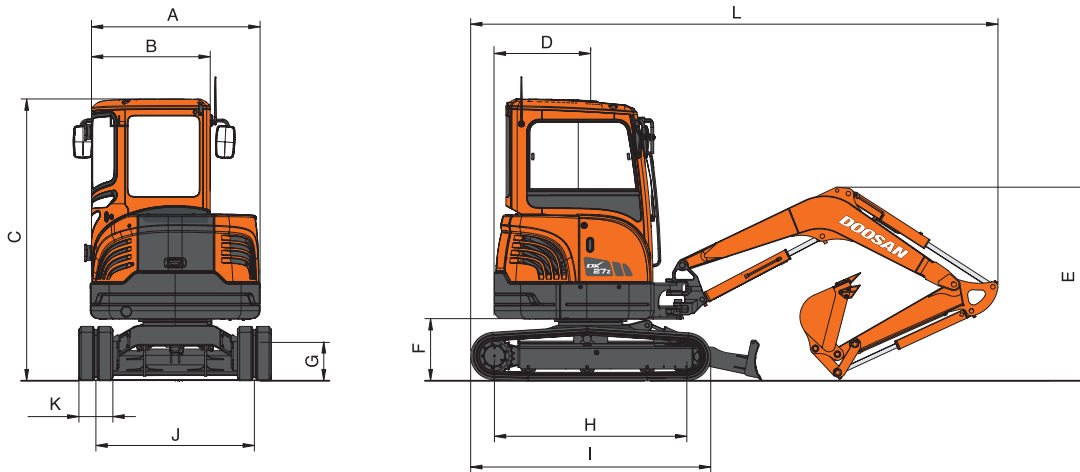

Boom type	2,000mm(6'7")	
Arm type	1,100mm(3'7")	1,300mm(4'3")
A Overall width of upper structure	1,440mm(4'9")	←
B Overall width of cab	1,030mm(3'5")	←
C Overall height of cab	2,445mm(8'00")	←
D Tail swing radius	760mm(2'6")	*835mm(2'9")
E Overall height	1,490mm(4'10")	←
F Clearance under counterweight	520mm(1'8")	←
G Ground Clearance	285mm(11.3")	←
H Tumbler distance	1,550mm(5'1")	←
I Track length	1,970mm(6'6")	←
J Track gauge	1,270mm(4'2")	←
K Track shoe width	300mm(1')	←
L Overall length	4,060mm(13'4")	←

* with Additional Weight

DIGGING FORCE (ISO)

Bucket (PCSA)	0.08m³	
	2,200 kgf	
Digging force	19.8 kN	
	4,453 lbf	
Arm	1,100mm	1,300mm
Digging force	1,455 kgf	1,305 kgf
	14.3 kN	12.8 kN
	3,208 lbf	2,877 lbf

WORKING RANGE

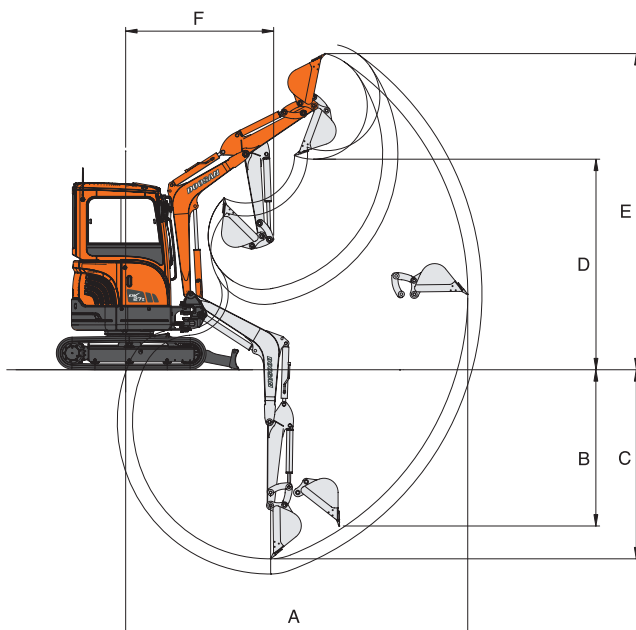

Boom type	2,000mm(6'7")	
Arm type	1,100mm (3'7")	1,300mm (4'3")
Bucket type (SAE)	0.08m ³ (0.11yd ³)	0.08m ³ (0.11yd ³)
A Max. Digging Reach	4,505mm (14'9")	4,690mm (15'5")
B Max. Vertical Wall Depth	2,295mm (7'6")	2,500mm (8'2")
C Max. Digging Depth	2,490mm (8'2")	2,690mm (8'10")
D Max. Loading Height	2,775mm (9'1")	2,935mm (9'8")
E Max. Digging Height	4,165mm (13'8")	4,280mm (14'1")
F Min. Swing Radius	1,950mm (6'5")	1,985mm (6'6")

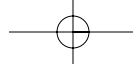

DX30Z

Dimensions & Working ranges

DIMENSIONS

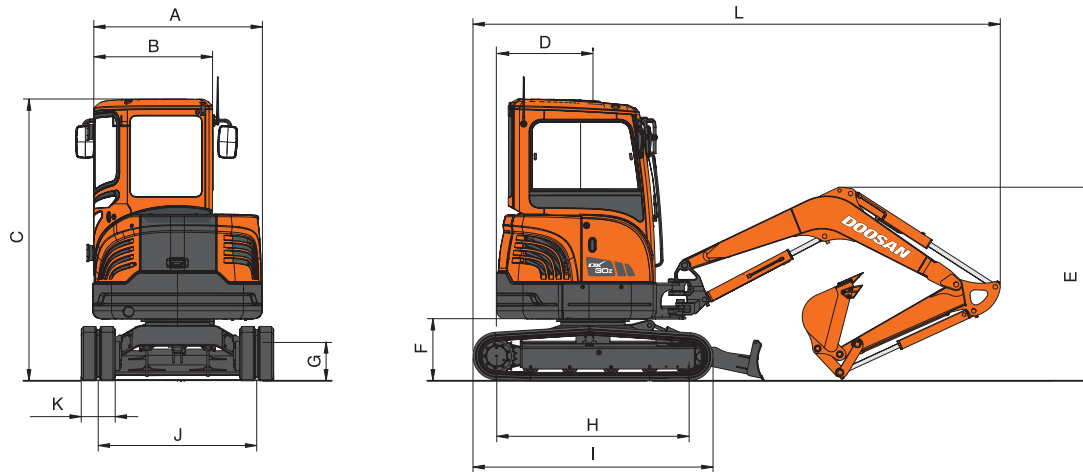

Boom type	2,280mm(7'6")	
Arm type	1,190mm(3'11")	1,300mm(4'3")
A Overall width of upper structure	1,440mm(4'9")	←
B Overall width of cab	1,030mm(3'5")	←
C Overall height of cab	2,480mm(8'2")	←
D Tail swing radius	775mm(2'7")	* 850mm(2'9")
E Overall height	1,590mm(5'3")	←
F Clearance under counterweight	535mm(1'9")	←
G Ground Clearance	300mm(1')	←
H Tumbler distance	1,650mm(5'5")	←
I Track length	2,100mm(6'11")	←
J Track gauge	1,250mm(4'1")	←
K Track shoe width	300mm(1')	←
L Overall length	4,507mm(14'9")	←

* with Additional Weight

DIGGING FORCE (ISO)

Bucket (PCSA)	0.091m³	
	2,800 kgf	
Digging force	27.5 kN	
	6,173 lbf	
Arm	1,190mm	1,300mm
Digging force	1,800 kgf	1,700 kgf
	17.7 kN	16.7 kN
	3,968 lbf	3,748 lbf

WORKING RANGE

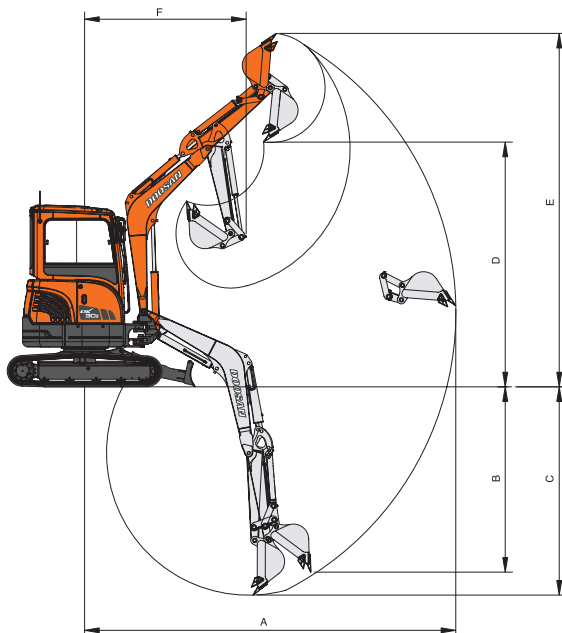

Boom type	2,280mm(7'6")	
Arm type	1,190mm (3'11")	1,300mm (4'3")
Bucket type (SAE)	0.09m ³ (0.12yd ³)	0.09m ³ (0.12yd ³)
A Max. Digging Reach	4,882mm (16'2")	4,984mm (16'4")
B Max. Vertical Wall Depth	2,278mm (7'6")	2,383mm (7'10")
C Max. Digging Depth	2,838mm (9'4")	2,948mm (9'8")
D Max. Loading Height	3,122mm (10'3")	3,185mm (10'5")
E Max. Digging Height	4,555mm (14'11")	4,618mm (15'2")
F Min. Swing Radius	2,015mm (6'7")	2,034mm (6'8")



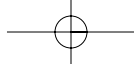

DX27Z

Lifting Capacity

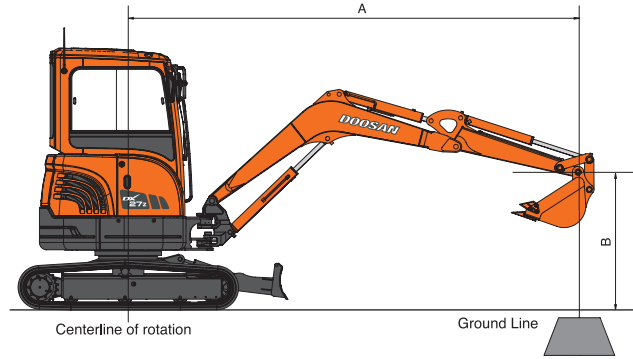

[Dozer up]

Metric Boom : 2,000mm(6'7") Arm : 1,100mm(3'7") Bucket : SAE 0.08m³(0.11yd³) CECE 0.07m³(0.09yd³) Shoe : 300mm(1') Unit : 1,000kg

A(m)	2		2.5		3		3.5		Max. Reach		A(m)
3					0.54	0.45			0.53	0.44	3.03
2.5					0.54	0.45			0.44	0.36	3.39
2			*0.68	0.60	0.54	0.45			0.39	0.32	3.63
1.5	1.03	0.83	0.71	0.58	0.53	0.44	0.41	0.34	0.37	0.30	3.76
1			0.69	0.57	0.52	0.43	0.41	0.34	0.36	0.30	3.80
0.5	0.97	0.77	0.68	0.55	0.51	0.42	0.40	0.33	0.36	0.30	3.76
O (Ground)	0.96	0.77	0.67	0.55	0.51	0.42	0.40	0.33	0.38	0.31	3.63
-0.5	0.96	0.77	0.67	0.55	0.51	0.42			0.42	0.35	3.40
-1	0.97	0.78	0.67	0.55	0.51	0.42			0.50	0.41	3.04
-1.5	0.99	0.79							0.70	0.58	2.46

Feet

Unit : 1,000lb

A(ft)	6		8		10		12		Max. Reach		A(ft)
10									1.19	0.99	9.79
8					1.16	0.96			0.95	0.79	11.25
6			1.65	1.36	1.15	0.95	0.85	0.70	0.84	0.70	12.08
4			1.60	1.31	1.13	0.93	0.84	0.70	0.79	0.66	12.44
2			1.56	1.27	1.11	0.91	0.83	0.69	0.79	0.66	12.39
O (Ground)	2.48	1.96	1.54	1.25	1.09	0.90			0.84	0.69	11.91
-2	2.49	1.97	1.54	1.25	1.09	0.90			0.95	0.79	10.94
-4	2.52	2.00	1.55	1.27					1.24	1.02	9.25

[Dozer Down]

Metric Boom : 2,000mm(6'7") Arm : 1,100mm(3'7") Bucket : SAE 0.08m³(0.11yd³) CECE 0.07m³(0.09yd³) Shoe : 300mm(1') Unit : 1,000kg

A(m)	2		2.5		3		3.5		Max. Reach		A(m)
3					*0.60	0.44			*0.60	0.44	3.03
2.5					*0.58	0.45			*0.61	0.36	3.39
2			*0.68	0.60	*0.63	0.44	*0.61	0.34	*0.62	0.32	3.63
1.5	*1.20	0.83	*0.87	0.58	*0.73	0.44	*0.65	0.34	*0.63	0.30	3.76
1			*1.06	0.57	*0.83	0.43	*0.70	0.34	*0.66	0.30	3.80
0.5	*1.27	0.77	*1.19	0.55	*0.91	0.42	*0.74	0.33	*0.68	0.30	3.76
O (Ground)	*1.70	0.77	*1.25	0.55	*0.94	0.42	*0.75	0.33	*0.71	0.31	3.63
-0.5	*1.69	0.77	*1.22	0.55	*0.92	0.42			*0.74	0.35	3.40
-1	*1.50	0.78	*1.09	0.55	*0.79	0.42			*0.77	0.41	3.04
-1.5	*1.12	0.79							*0.78	0.57	2.46

Feet

Unit : 1,000lb

A(ft)	6		8		10		12		Max. Reach		A(ft)
10									*1.33	0.99	9.79
8					*1.29	0.96			*1.34	0.78	11.25
6			*1.67	1.36	*1.45	0.95	*1.37	0.70	*1.37	0.69	12.08
4			*2.24	1.31	*1.70	0.93	*1.45	0.70	*1.42	0.66	12.44
2			*2.69	1.27	*1.92	0.91	*1.54	0.69	*1.49	0.65	12.39
O (Ground)	*2.79	1.95	*2.86	1.25	*2.03	0.90			*1.56	0.69	11.91
-2	*4.17	1.97	*2.74	1.25	*1.95	0.90			*1.64	0.79	10.94
-4	*3.39	1.99	*2.26	1.26					*1.71	1.02	9.25

- The load point is a hook located on the back of the bucket.
- * Rated loads are based on hydraulic capacity.
- Rated loads do not exceed 87% of hydraulic capacity or 75% of tipping capacity.

: Rating Over Front
 : Rating Over Side or 360 degree



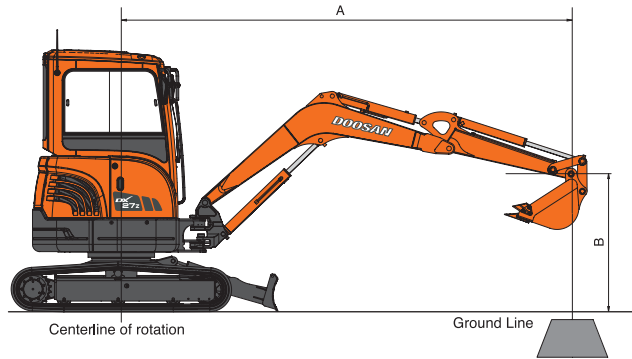

[Dozer up - Option Arm & Additional Weight]

Metric Boom : 2,000mm(6'7") Arm : 1,300mm(4'3") Bucket : SAE 0.08m³(0.11yd³) CECE 0.07m³(0.09yd³) Shoe : 300mm(1') Unit : 1,000kg

A(m)	2		2.5		3		3.5		Max. Reach		A(m)
B(m)											
3-5									*0.55	0.55	2.76
3					*0.50	0.49			*0.51	0.42	3.27
2.5					*0.50	0.49	0.46	0.38	*0.43	0.36	3.61
2					*0.57	0.49	0.45	0.38	*0.39	0.33	3.82
1.5	*1.00	0.91	*0.77	0.64	0.58	0.48	0.45	0.38	*0.37	0.31	3.95
1	1.08	0.87	0.75	0.62	0.57	0.45	0.45	0.37	*0.36	0.30	3.99
0.5	1.05	0.85	0.74	0.61	0.56	0.47	0.44	0.37	*0.36	0.30	3.95
O (Ground)	1.04	0.84	0.73	0.60	0.55	0.46	0.44	0.36	*0.38	0.32	3.83
-0.5	1.04	0.84	0.73	0.59	0.55	0.46	0.44	0.36	*0.42	0.35	3.61
-1	1.05	0.84	0.73	0.60	0.55	0.45			*0.48	0.40	3.28
-1.5	1.06	0.85	0.73	0.60					*0.63	0.52	2.78

Feet

Unit : 1,000lb

A(ft)	6		8		10		12		Max. Reach		A(ft)
B(ft)											
10					*1.13	1.05			1.14	0.95	10.61
8					*1.13	1.06			0.94	0.78	11.94
6			*1.43	*1.43	1.25	1.05	0.93	0.78	0.84	0.70	12.71
4			1.75	1.44	1.23	1.02	0.92	0.77	0.80	0.67	13.05
2			1.70	1.39	1.20	1.00	0.91	0.76	0.80	0.67	13.00
O (Ground)	2.68	2.13	1.67	1.37	1.19	0.98	0.90	0.75	0.84	0.70	12.56
-2	2.69	2.13	1.66	1.36	1.18	0.98			0.94	0.78	11.65
-4	2.71	2.15	1.67	1.37	1.19	0.99			1.17	0.97	10.13
-4	*2.39	2.20							*1.65	1.57	7.43

[Dozer down - Option Arm & Additional Weight]

Metric Boom : 2,000mm(6'7") Arm : 1,300mm(4'3") Bucket : SAE 0.08m³(0.11yd³) CECE 0.07m³(0.09yd³) Shoe : 300mm(1') Unit : 1,000kg

A(m)	2		2.5		3		3.5		Max. Reach		A(m)
B(m)											
3-5									*0.55	*0.55	2.76
3					*0.50	0.49			*0.54	0.42	3.27
2.5					*0.50	0.49	*0.54	0.38	*0.55	0.36	3.61
2					*0.57	0.49	*0.56	0.38	*0.56	0.33	3.82
1.5	*1.00	0.91	*0.77	0.64	*0.66	0.48	*0.61	0.38	*0.58	0.31	3.95
1	*1.45	0.87	*0.98	0.62	*0.77	0.47	*0.66	0.37	*0.60	0.30	3.99
0.5	*1.51	0.85	*1.14	0.61	*0.87	0.46	*0.72	0.37	*0.63	0.30	3.95
O (Ground)	*1.68	0.84	*1.23	0.60	*0.93	0.46	*0.75	0.36	*0.65	0.32	3.83
-0.5	*1.74	0.84	*1.23	0.59	*0.93	0.45	*0.73	0.36	*0.68	0.35	3.61
-1	*1.59	0.84	*1.15	0.60	*0.86	0.45			*0.72	0.40	3.28
-1.5	*1.30	0.85	*0.93	0.60					*0.75	0.52	2.78

Feet

Unit : 1,000lb

A(ft)	6		8		10		12		Max. Reach		A(ft)
B(ft)											
10					*1.13	1.05			*1.20	0.95	10.61
8					*1.13	1.06			*1.22	0.78	11.94
6			*1.43	*1.43	*1.31	1.05	*1.25	0.78	*1.26	0.70	12.71
4			*2.03	1.44	*1.58	1.02	*1.37	0.77	*1.31	0.67	13.05
2			*2.55	1.39	*1.84	1.00	*1.49	0.76	*1.37	0.67	13.00
O (Ground)	*2.75	2.13	*2.81	1.37	*1.99	0.98	*1.54	0.75	*1.44	0.70	12.56
-2	*4.24	2.13	*2.79	1.36	*1.99	0.98			*1.52	0.78	11.65
-4	*3.73	2.15	*2.46	1.37	*1.66	0.99			*1.61	0.97	10.13
-4	*2.39	2.20							*1.65	1.57	7.43

1. The load point is a hook located on the back of the bucket.
2. * Rated loads are based on hydraulic capacity.
3. Rated loads do not exceed 87% of hydraulic capacity or 75% of tipping capacity.

: Rating Over Front

: Rating Over Side or 360 degree

DX30Z

Lifting Capacity

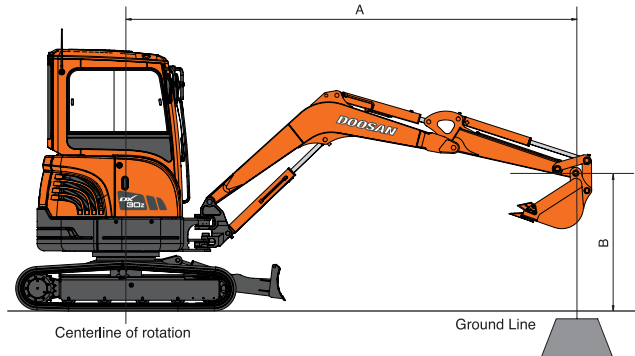

[Dozer up]

Metric	Boom : 2,280mm(7'6")		Arm : 1,190mm(3'11")		Bucket : SAE 0.09m³(0.12yd³) CECE 0.078m³(0.10yd³)		Shoe : 300mm(1')		Unit : 1,000kg		
A(m)	2		2.5		3		3.5		Max. Reach		
B(m)											A(m)
3					*0.50	0.50			0.55	0.38	3.50
2.5					*0.55	0.50	0.56	0.38	0.48	0.33	3.81
2	*0.90	*0.90	*0.73	0.66	*0.65	0.49	0.55	0.38	0.44	0.30	4.01
1.5			0.95	0.63	0.70	0.48	0.55	0.37	0.42	0.28	4.12
1			0.92	0.61	0.69	0.47	0.54	0.37	0.41	0.27	4.16
0.5			0.90	0.60	0.68	0.46	0.53	0.36	0.41	0.28	4.12
O (Ground)	*1.27	0.83	0.90	0.59	0.67	0.45	0.53	0.36	0.43	0.29	4.00
-0.5	1.31	0.83	0.90	0.59	0.67	0.45	0.53	0.35	0.47	0.31	3.80
-1	1.32	0.84	0.90	0.59	0.67	0.45			0.54	0.36	3.49
-1.5	1.34	0.86	0.91	0.60	0.68	0.46			0.67	0.45	3.02

Feet

A(ft)	6		8		10		12		Max. Reach		A(ft)
B(ft)											A(ft)
10					*1.12	1.07			1.24	0.85	11.4
8					*1.23	1.06	1.14	0.78	1.05	0.71	12.7
6			*1.83	1.49	*1.51	1.04	1.13	0.77	0.95	0.64	13.4
4			2.14	1.42	1.49	1.01	1.12	0.76	0.91	0.61	13.7
2			2.08	1.37	1.47	0.98	1.10	0.74	0.91	0.61	13.7
O (Ground)	*2.10	*2.10	2.06	1.35	1.45	0.97	1.09	0.73	0.95	0.64	13.1
-2	3.43	2.14	2.06	1.35	1.44	0.96	1.09	0.73	1.06	0.71	12.3
-4	3.47	2.17	2.08	1.37	1.45	0.97			1.29	0.87	10.10

[Dozer Down]

Metric	Boom : 2,280mm(7'6")		Arm : 1,190mm(3'11")		Bucket : SAE 0.09m³(0.12yd³) CECE 0.078m³(0.10yd³)		Shoe : 300mm(1')		Unit : 1,000kg		
A(m)	2		2.5		3		3.5		Max. Reach		
B(m)											A(m)
3					*0.50	0.50			*0.57	0.38	3.50
2.5					*0.55	0.49	*0.56	0.38	*0.59	0.33	3.81
2	*0.90	*0.90	*0.73	0.65	*0.65	0.49	*0.61	0.38	*0.61	0.30	4.01
1.5			*0.98	0.63	*0.78	0.48	*0.68	0.37	*0.63	0.28	4.12
1			*1.22	0.61	*0.92	0.46	*0.76	0.36	*0.66	0.27	4.16
0.5			*1.38	0.59	*1.02	0.45	*0.83	0.36	*0.69	0.28	4.12
O (Ground)	*1.27	0.83	*1.45	0.59	*1.09	0.45	*0.87	0.36	*0.72	0.29	4.00
-0.5	*2.00	0.83	*1.44	0.59	*1.10	0.45	*0.87	0.35	*0.76	0.31	3.80
-1	*1.88	0.84	*1.37	0.59	*1.05	0.45			*0.81	0.36	3.49
-1.5	*1.63	0.85	*1.20	0.60	*0.88	0.46			*0.87	0.45	3.02

Feet

A(ft)	6		8		10		12		Max. Reach		A(ft)
B(ft)											A(ft)
10					*1.12	1.07			*1.25	0.85	11.4
8					*1.23	1.06	*1.27	0.77	*1.30	0.71	12.7
6			*1.83	1.48	*1.51	1.04	*1.37	0.77	*1.35	0.64	13.4
4			*2.58	1.42	*1.86	1.01	*1.54	0.75	*1.42	0.61	13.7
2			*3.12	1.37	*2.16	0.98	*1.70	0.74	*1.50	0.60	13.7
O (Ground)	*2.10	*2.10	*3.32	1.35	*2.34	0.97	*1.80	0.73	*1.59	0.63	13.1
-2	*4.05	2.13	*3.28	1.35	*2.35	0.96	*1.77	0.73	*1.70	0.71	12.3
-4	*4.46	2.16	*2.99	1.36	*2.14	0.97			*1.83	0.86	10.10

- The load point is a hook located on the back of the bucket.
- * Rated loads are based on hydraulic capacity.
- Rated loads do not exceed 87% of hydraulic capacity or 75% of tipping capacity.

: Rating Over Front

: Rating Over Side or 360 degree

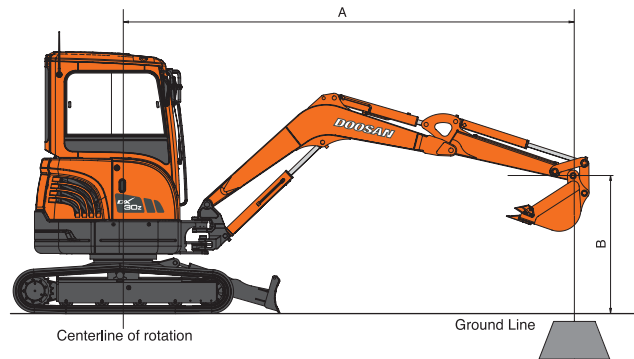

[Dozer up - Option Arm & Additional Weight]

Metric		Boom : 2,280mm(7'6")		Arm : 1,300mm(4'3")		Bucket : SAE 0.09m ³ (0.12yd ³) CECE 0.078m ³ (0.10yd ³)		Shoe : 300mm(1')		Unit : 1,000kg	
A(m)	B(m)	2		2.5		3		3.5		Max. Reach	
3						*0.46	*0.46	*0.52	0.41	*0.54	0.39
2.5						*0.51	*0.51	*0.53	0.42	*0.56	0.34
2				*0.66	*0.66	*0.61	0.53	*0.58	0.41	*0.58	0.31
1.5				*0.92	0.69	*0.74	0.52	*0.65	0.41	*0.60	0.29
1				*1.17	0.66	*0.88	0.51	*0.74	0.40	*0.63	0.29
0.5				*1.34	0.65	*1.00	0.50	*0.81	0.39	*0.66	0.29
O (Ground)		*1.29	0.90	*1.43	0.64	*1.07	0.49	*0.86	0.39	*0.69	0.30
-0.5		*1.90	0.90	*1.44	0.64	*1.09	0.49	*0.87	0.39	*0.73	0.33
-1		*1.92	0.91	*1.39	0.64	*1.06	0.49	*0.83	0.39	*0.78	0.37
-1.5		*1.70	0.92	*1.24	0.65	*0.93	0.49			*0.83	0.45

Feet

Unit : 1,000lb

Metric		6		8		10		12		Max. Reach	
A(ft)	B(ft)										
10						*1.02	*1.02			*1.19	0.87
8						*1.14	1.14	*1.19	0.85	*1.24	0.74
6				*1.68	1.61	*1.42	1.13	*1.31	0.84	*1.29	0.67
4				*2.44	1.54	*1.78	1.10	*1.49	0.83	*1.36	0.64
2				*3.03	1.49	*2.10	1.07	*1.66	0.81	*1.44	0.64
O (Ground)		*2.15	*2.15	*3.29	1.46	*2.31	1.05	*1.78	0.80	*1.53	0.67
-2		*3.82	2.30	*3.29	1.46	*2.35	1.05	*1.79	0.80	*1.63	0.74
-4		*4.62	2.33	*3.06	1.47	*2.20	1.05			*1.76	0.88

[Dozer down - Option Arm & Additional Weight]

Metric		Boom : 2,280mm(7'6")		Arm : 1,300mm(4'3")		Bucket : SAE 0.09m ³ (0.12yd ³) CECE 0.078m ³ (0.10yd ³)		Shoe : 300mm(1')		Unit : 1,000kg	
A(m)	B(m)	2		2.5		3		3.5		Max. Reach	
3						*0.46	*0.46	*0.52	0.41	*0.54	0.39
2.5						*0.51	*0.51	*0.53	0.42	*0.56	0.34
2				*0.66	*0.66	*0.61	0.53	*0.58	0.41	*0.58	0.31
1.5				*0.92	0.69	*0.74	0.52	*0.65	0.41	*0.60	0.29
1				*1.17	0.66	*0.88	0.51	*0.74	0.40	*0.63	0.29
0.5				*1.34	0.65	*1.00	0.50	*0.81	0.39	*0.66	0.29
O (Ground)		*1.29	0.90	*1.43	0.64	*1.07	0.49	*0.86	0.39	*0.69	0.30
-0.5		*1.90	0.90	*1.44	0.64	*1.09	0.49	*0.87	0.39	*0.73	0.33
-1		*1.92	0.91	*1.39	0.64	*1.06	0.49	*0.83	0.39	*0.78	0.37
-1.5		*1.70	0.92	*1.24	0.65	*0.93	0.49			*0.83	0.45

Feet

Unit : 1,000lb

Metric		6		8		10		12		Max. Reach	
A(ft)	B(ft)										
10						*1.02	*1.02			*1.19	0.87
8						*1.14	1.14	*1.19	0.85	*1.24	0.74
6				*1.68	1.61	*1.42	1.13	*1.31	0.84	*1.29	0.67
4				*2.44	1.54	*1.78	1.10	*1.49	0.83	*1.36	0.64
2				*3.03	1.49	*2.10	1.07	*1.66	0.81	*1.44	0.64
O (Ground)		*2.15	*2.15	*3.29	1.46	*2.31	1.05	*1.78	0.80	*1.53	0.67
-2		*3.82	2.30	*3.29	1.46	*2.35	1.05	*1.79	0.80	*1.63	0.74
-4		*4.62	2.33	*3.06	1.47	*2.20	1.05			*1.76	0.88

1. The load point is a hook located on the back of the bucket.
2. * Rated loads are based on hydraulic capacity.
3. Rated loads do not exceed 87% of hydraulic capacity or 75% of tipping capacity.

: Rating Over Front

: Rating Over Side or 360 degree

DX27Z/DX30Z

Standard & Optional equipment

STANDARD EQUIPMENT

Cabin & Interior

- All weather sound suppressed type cab
- Adjustable suspension seat
- Pull-up type front window and removable lower front window
- Room light
- Cigarette lighter
- Cup holder
- Heater and defroster
- Fresh air filter
- Storage box

Safety

- ROPS & TOPS Cabin
- Hydraulic safety lock lever
- Safety glass
- Hammer for emergency escape

Others

- Double element air cleaner
- Water separator
- Alternator (12V, 40 amps)
- Electric horn
- Halogen working lights (Boom mounted 1)
- Piping for hammer (One way) and for rotation (Two way)
- Rubber shoe
- Maintenance free battery

OPTIONAL EQUIPMENT

Safety

- ROPS & TOPS Canopy (4-Pillar)
- Rotating beacon
- Accumulator
- Travel alarm
- Side mirror

Others

- Track guards(Front)
- Halogen working light
 - Boom mounted 2
 - Cabin/Canopy mounted 2
- Piping for quick clamp
- Lever pattern changing valve



