

# SKID STEER LOADER



## Specifications

Operating Weight	6480 lbs (2939 kg)
Horsepower	60 hp (44.7 kw)
Height to Bucket Pin	115 in (2921 mm)
Operating Capacity	1500 lbs (680 kg)

## Features

- ▶ Easy operation with pilot-operated joystick controls and comfortable operator station.
- ▶ Terex® skid steer loaders have one of the highest ground clearances in the industry at 10.5 inches (unloaded), which along with our 28.3 degree angle of departure makes our unit the one to beat when driving in the toughest job site conditions.
- ▶ Our skid steer loaders were engineered with a low tower design and steep engine hood angles, providing superb visibility, while producing excellent lift heights, dump reach, and weight capacities.

**WORKS FOR YOU.™**

# SPECIFICATIONS

## OPERATING SPECIFICATIONS

Loader Arms	Radial
Operating Weight	6480 lbs (2939 kg)
Shipping Weight	5755 lbs (2610 kg)
Tipping Load	3000 lbs (1361 kg)
Operating Capacity	1500 lbs (680 kg)
Maximum Travel Speed (with optional 2 speed transmission)	12 mph (19.3 kph)
Height to Bucket Pin	115 in (2921 mm)
Dump Height at Bucket Discharge	87 in (2210 mm)
Dump Reach at Bucket Discharge	22 in (559 mm)
Max Dump Angle at Full Height	40°
Bucket Breakout Force	3900 lbs (1770 kg)
Arm Lifting Force	3000 lbs (1360 kg)
Rear angle of Departure	28.3°
Bucket Roll Back at Ground level	27°
Ground Clearance	10.5" (26.6 mm)
Overall Length with Bucket	137 in (3454 mm)

## ENGINE

Type	Diesel, 4-Cylinder, Turbocharged
Model	Perkins 404D-22T
Displacement	135 in <sup>3</sup> (2.2 L)
Gross Horsepower @ 2800 rpm	60 hp (44.7 kW)
Torque, Peak	140 ft-lb (190 Nm)
Cooling System	Engine-Driven Fan And Coolant/Anti-Freeze Filled Radiator
Engine Block Heater	Standard, Ac Plug-In Type
Intake Air Cleaner	Dual Stage
Emissions Controls	Meets All U.S. Epa Interim Tier 4 Standards

## DRIVE TRAIN

Drive System	Hydrostatic
Chain Case	Bow Tie Drive System
Chain Size	80 ANSI Chain
Wheel Size	10x16.5
Width Over Tires	66 in (1676 mm)
Tractive Effort	8453 lbs (3826 kg)
Wheel Base	40.6 in (1031 mm)

## SERVICE CAPACITIES

Fuel Tank	25 gal (95 L)
Hydraulic Tank	8 gal (30 L)
Engine Coolant/Antifreeze	3.5 gal (13 L)
Engine Oil (including filter)	11.2 quarts (10.6 L)



## AUXILIARY HYDRAULIC SYSTEM

System Pressure, max.	3335 (230 bar)
Controls	Pilot Hydraulic Joystick
Couplers	3/4" Flat Faced
Auxiliary Pump Flow	17.1 gpm (65 lpm)
Optional Flow	32 gpm (121 lpm)

## ELECTRICAL SYSTEM

Normal Charge	12V
Battery	770 CCA
Charging System	65 Amp Alternator
Outlets	1-12V Port Inside Operator Station

## OPERATOR STATION

Seat: Standard seat with an optional adjustable suspension seat available.	
Loader Control: Right-hand pilot hydraulic joystick controls loader lift/tilt, with intermittent control of auxiliary hydraulics.	
Drive Control: Left-hand pilot hydraulic joystick controls machine speed and direction.	
Engine speed control	Foot Throttle
Indicators/Gauges	Fuel Tachometer Engine Temperature Hour Meter Battery Two-Speed Oil Level Hydraulic Temperature Water Temperature
ROPS/FOPS	Meets ISO 3471:2008 ISO 6683:2005 ISO 3449:2005 Level 1
Illumination	2 Forward Facing Lights 2 Rear Facing Lights

**DIMENSIONS: GENERAL PURPOSE BUCKET**

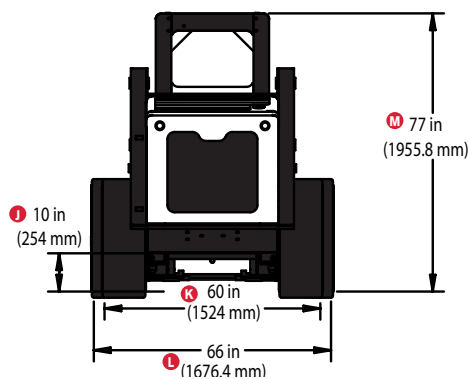
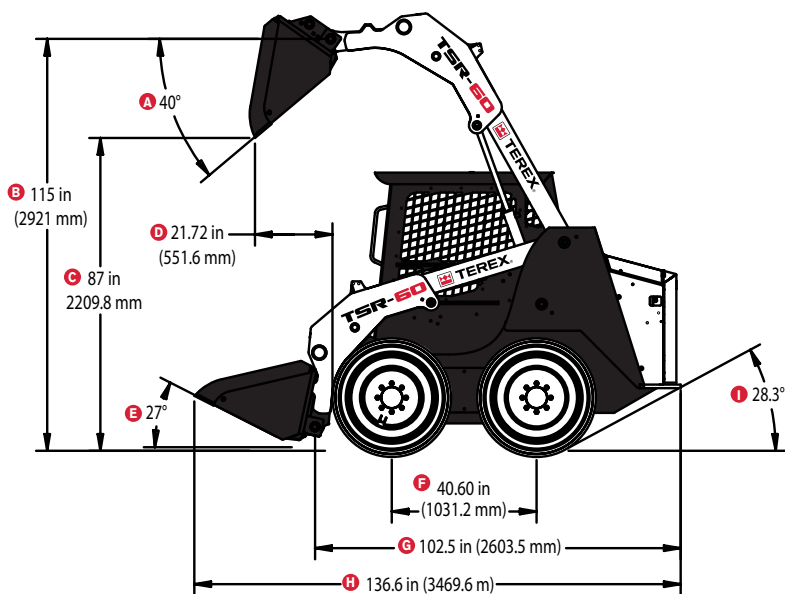

**MEASUREMENTS**

A	Dump Angle	H	Overall Length with Bucket
B	Height to Hinge Pin	I	Rear Angle of Departure
C	Height to Bucket Discharge	J	Loaded Ground Clearance (10.5 in unloaded)
D	Reach at Full Height	K	Width Between Tires with Rims Reversed
E	Bucket Rollback at Ground Level	L	Width Between Tires
F	Wheel Base	M	Overall Height to Top of ROPS
G	Overall Length without Bucket		

# OPTIONAL ATTACHMENTS

## ATTACHMENT INTERFACE AND ATTACHMENTS

Auger Drive And Bits	Brush Cutter, Rotary	Snow Blade
Backhoe	Dozer Blade	Snow Blower
Broom, Rotary	Eliminator Rake	Stump Grinder
Bucket, General Purpose	Grapple Bucket	Trencher
Bucket, Light Material	Pallet Forks	Vibratory Roller
Bucket, Multi-Purpose	Power Box Rake	

*Additional attachments available upon request.*

[www.terex.com](http://www.terex.com)

Effective Date: November 2010. Product specifications and prices are subject to change without notice or obligation. The photographs and/or drawings in this document are for illustrative purposes only. Refer to the appropriate Operator's Manual for instructions on the proper use of this equipment. Failure to follow the appropriate Operator's Manual when using our equipment or to otherwise act irresponsibly may result in serious injury or death. The only warranty applicable to our equipment is the standard written warranty applicable to the particular product and sale and Terex makes no other warranty, express or implied. Products and services listed may be trademarks, service marks, or trade names of Terex Corporation and/or its subsidiaries in the USA and other countries. All rights are reserved. Terex is a registered trademark of Terex Corporation in the USA and many other countries. © 2010 Terex Corporation.

Terex Construction 8800 Rostin Road, Southaven, MS 38671 USA  
Tel +1 (888) 90-TEREX [www.terex.com](http://www.terex.com)



**WORKS FOR YOU.™**

TSR60 1110 PN 280226